

PLAN

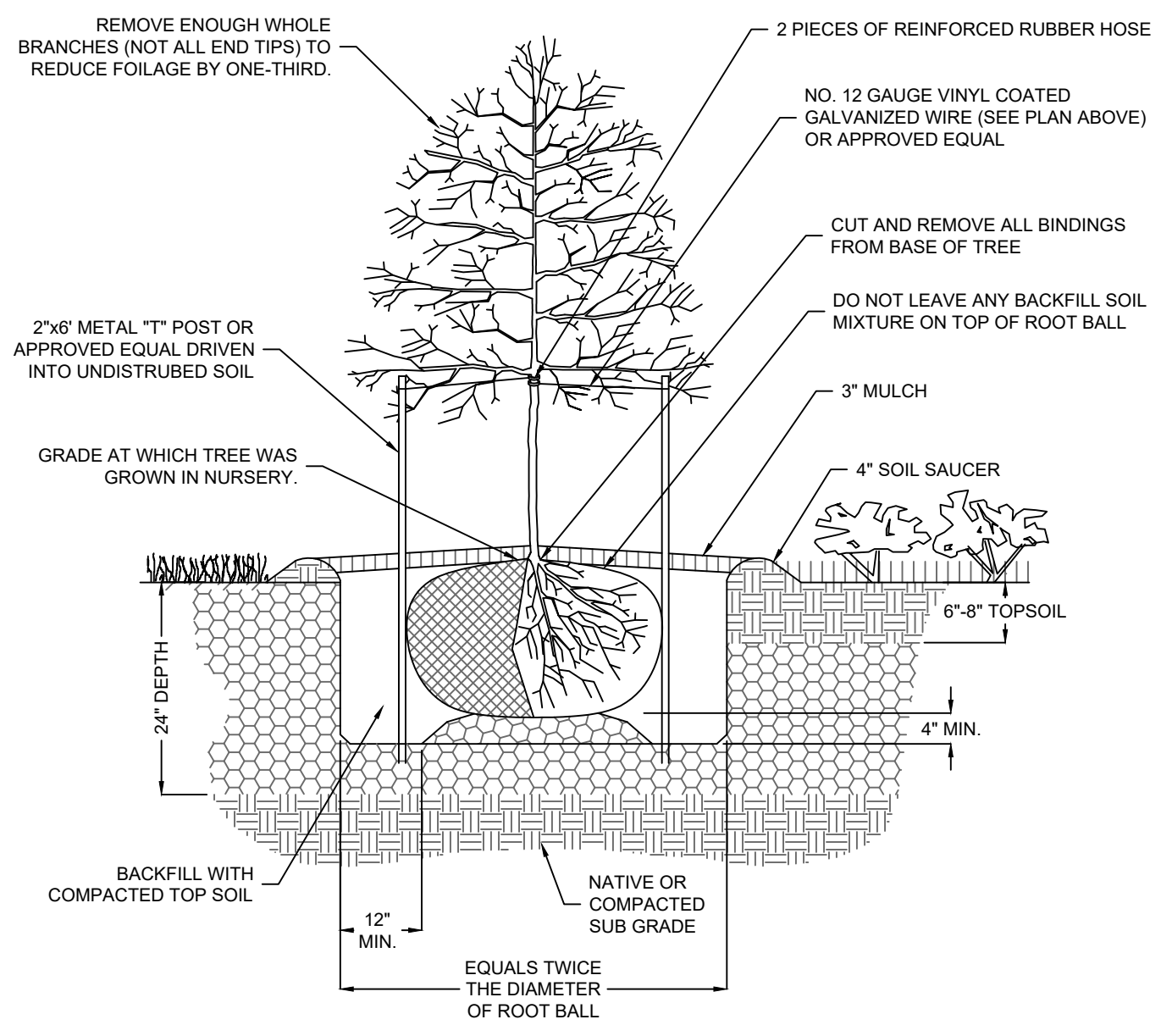

NOTE:
1. BACKFILL AROUND ROOT BALL IN 6"-8" LAYERS WATERING EACH LAYER UNTIL SETTLED TO AVOID AIR POCKETS.
2. LANDSCAPE CONTRACTOR IS RESPONSIBLE FOR THE REMOVAL OF TREE STABILIZATION AT THE END OF THE SECOND GROWING SEASON.

TREE PLANTING DETAIL

SCALE: NONE

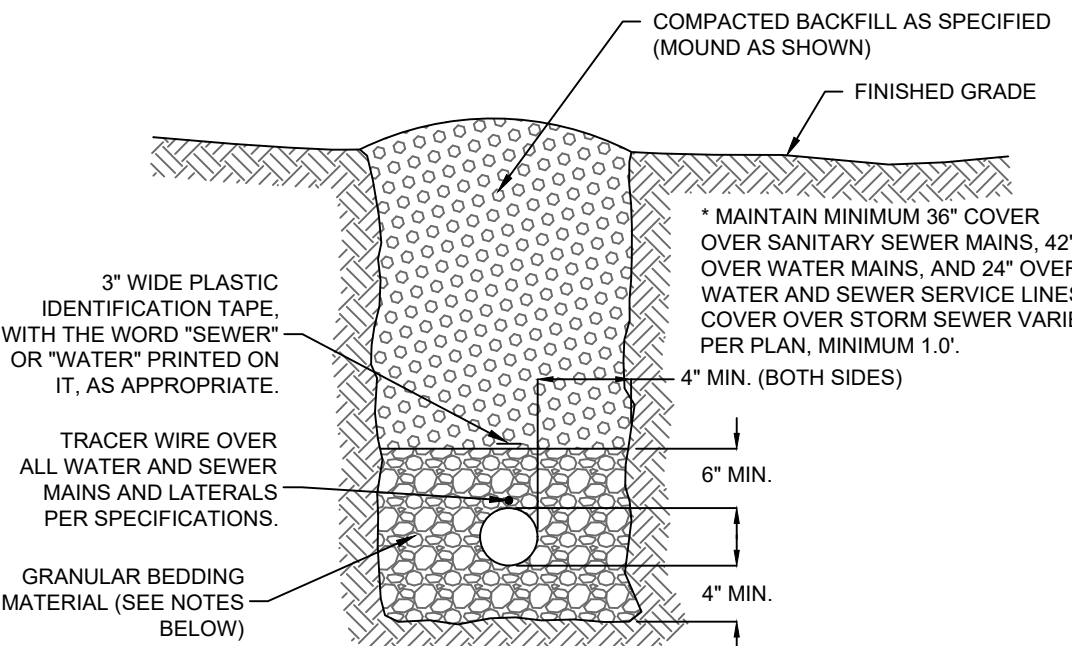

GRANULAR BEDDING MATERIAL SHALL BE CRUSHED STONE OR GRAVEL CONFORMING TO THE REQUIREMENTS OF ASTM D 2321 FOR CLASS I MATERIALS, EXCEPT WITH THE FOLLOWING GRADATION:

SIEVE SIZE	% PASSING
1"	100
3/4"	55-90
NO. 4	8-40
NO. 10	0-15
NO. 200	0-4

TYPICAL PIPE INSTALLATION DETAIL

SCALE: NONE

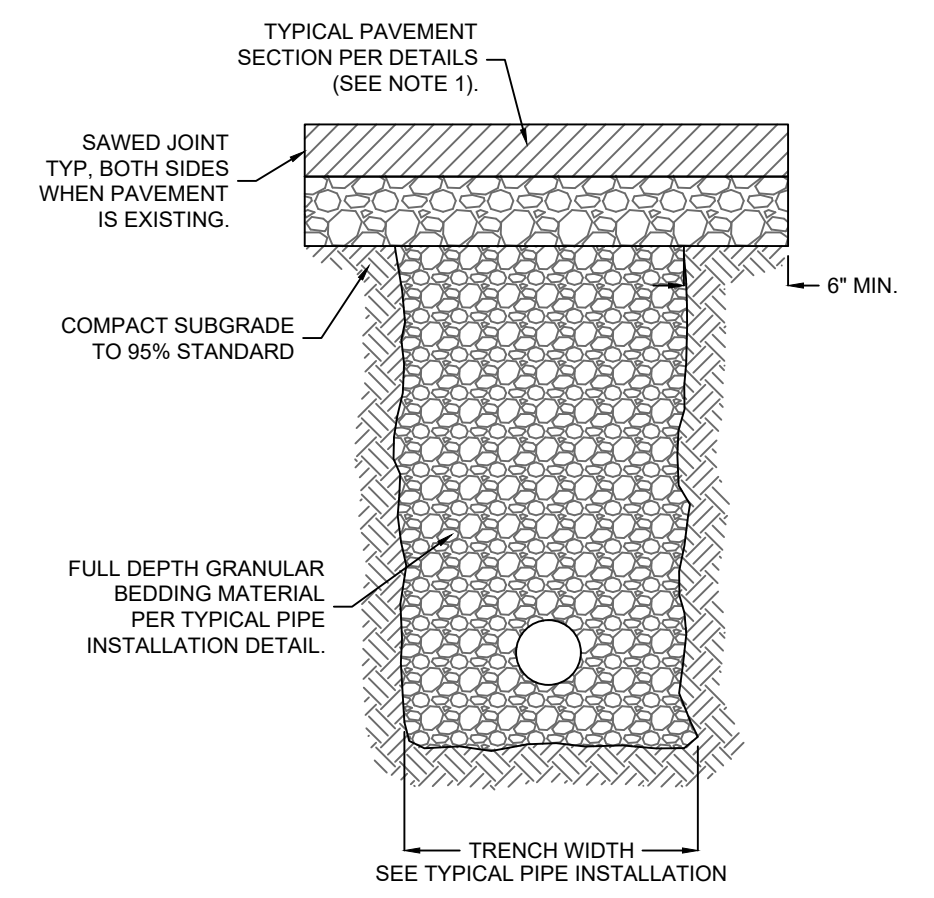

NOTES:

1. INCREASE ASPHALT PAVEMENT SECTION THICKNESS BY 1.5 TIMES THE RECOMMENDED PAVEMENT THICKNESS WHERE PIPES ARE TO BE INSTALLED UNDER EXISTING PAVEMENT.

PIPE INSTALLATION UNDER PAVEMENT

SCALE: NONE

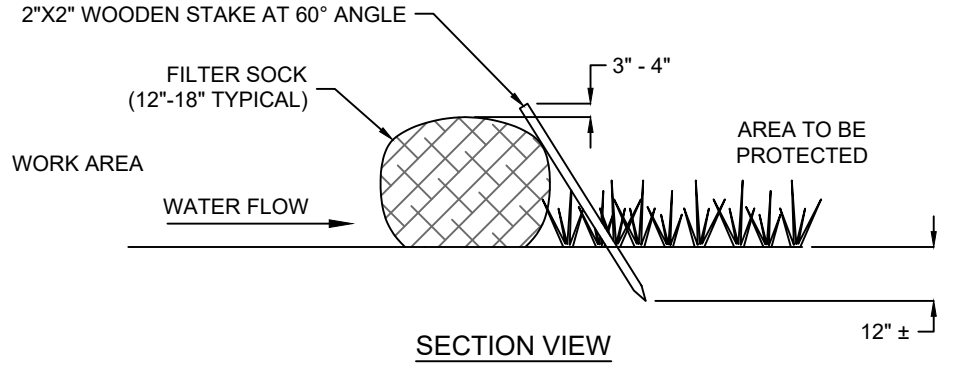

NOTES:
1. ALL MATERIAL TO MEET MANUFACTURER'S REQUIREMENTS.
2. FILTER SOCK DEPICTED IS FOR MINIMUM SLOPES. GREATER SLOPES MAY REQUIRE LARGER SOCKS PER ENGINEER.
3. COMPOST MATERIAL TO BE DISPERSED ON SITE, AS DETERMINED BY ENGINEER.

COMPOST FILTER SOCK DETAIL

SCALE: NONE

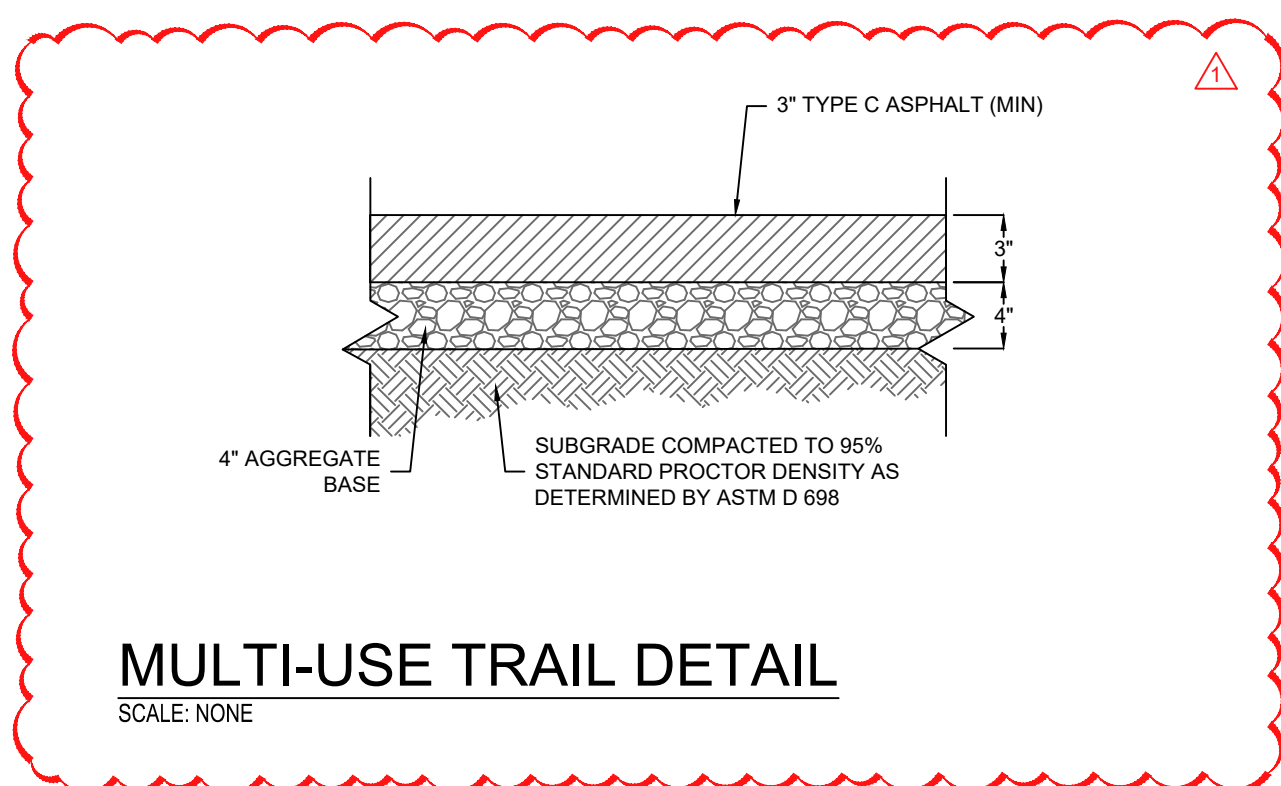

MULTI-USE TRAIL DETAIL

SCALE: NONE

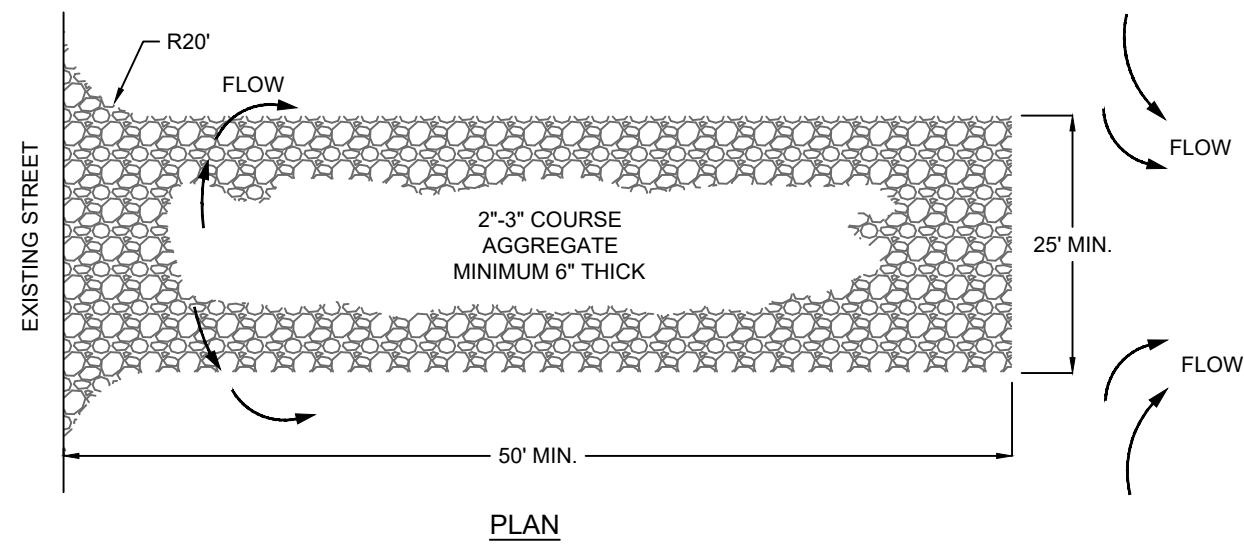

NOTES:

1. THE ENTRANCE SHALL BE MAINTAINED IN A CONDITION THAT WILL PREVENT TRACKING OR FLOWING OF SEDIMENT ONTO PUBLIC RIGHTS-OF-WAY. THIS MAY REQUIRE TOP DRESSING, REPAIR AND/OR CLEAN OUT OF ANY MEASURES USED TO TRAP SEDIMENT.
2. WHEN NECESSARY, WHEELS SHALL BE CLEANED PRIOR TO ENTRANCE ONTO PUBLIC RIGHT-OF-WAY.
3. WHEN WASHING IS REQUIRED, IT SHALL BE DONE ON AN AREA STABILIZED WITH CRUSHED STONE THAT DRAINS INTO AN APPROVED SEDIMENT TRAP OR SEDIMENT BASIN.

TEMPORARY CONSTRUCTION ENTRANCE

SCALE: NONE

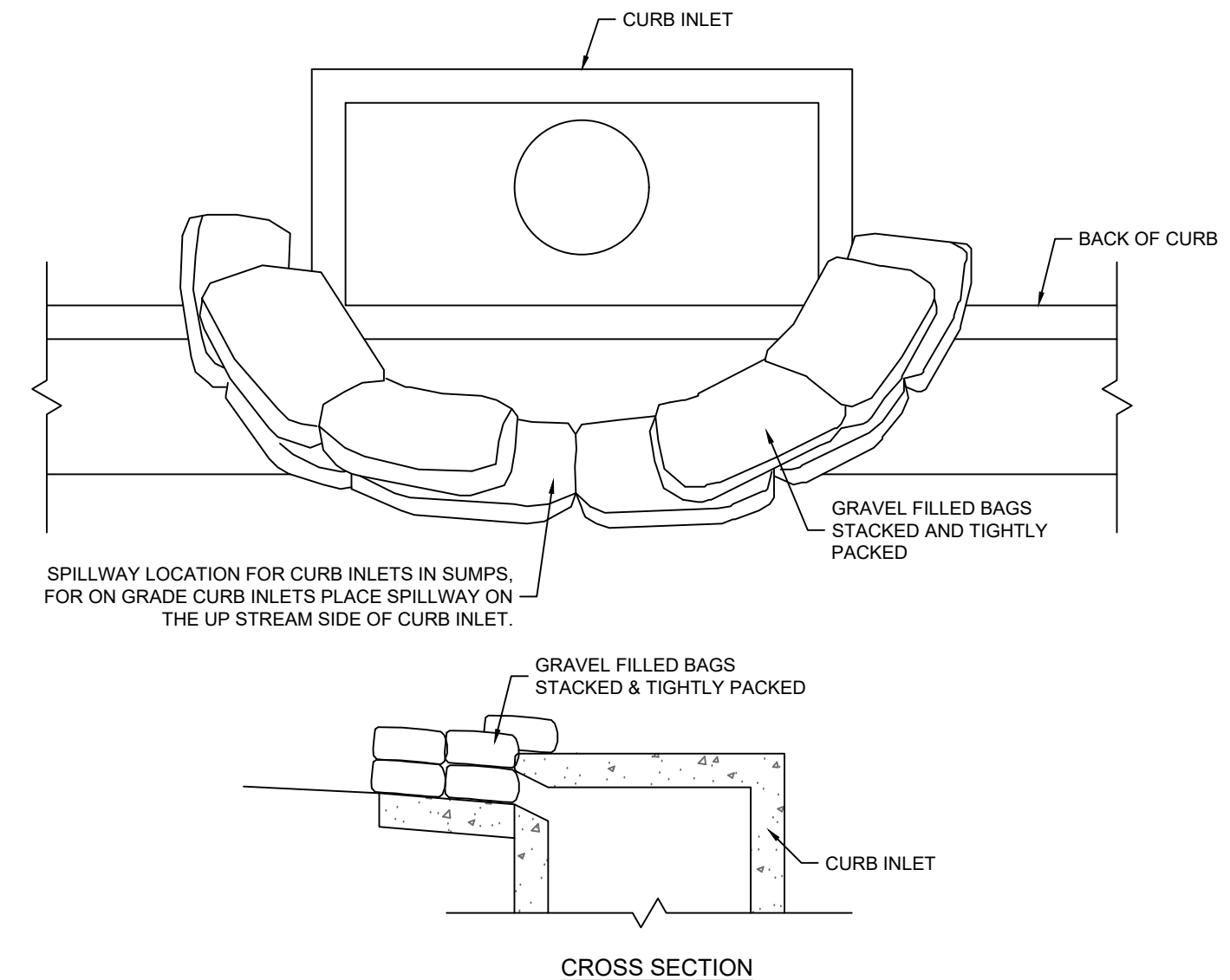

NOTES:

1. PLACE CURB INLET SEDIMENT BARRIERS ON GENTLY SLOPING STREET SEGMENTS OR IN SUMPS WHERE WATER CAN POND AND ALLOW SEDIMENT TO SEPARATE FROM RUNOFF.
2. BAGS, OF EITHER BURLAP OR WOVEN GEOTEXTILE FABRIC, ARE FILLED WITH GRAVEL, LAYERED AND PACKED TIGHTLY.
3. LEAVE ONE BAG GAP IN THE TOP ROW TO PROVIDE A SPILLWAY FOR OVERFLOW.
4. INSPECT BARRIERS AND REMOVE SEDIMENT AFTER EACH RAINFALL EVENT. SEDIMENT AND GRAVEL MUST BE REMOVED FROM THE TRAVELED WAY IMMEDIATELY.

CURB INLET SEDIMENT BARRIER DETAIL

SCALE: NONE

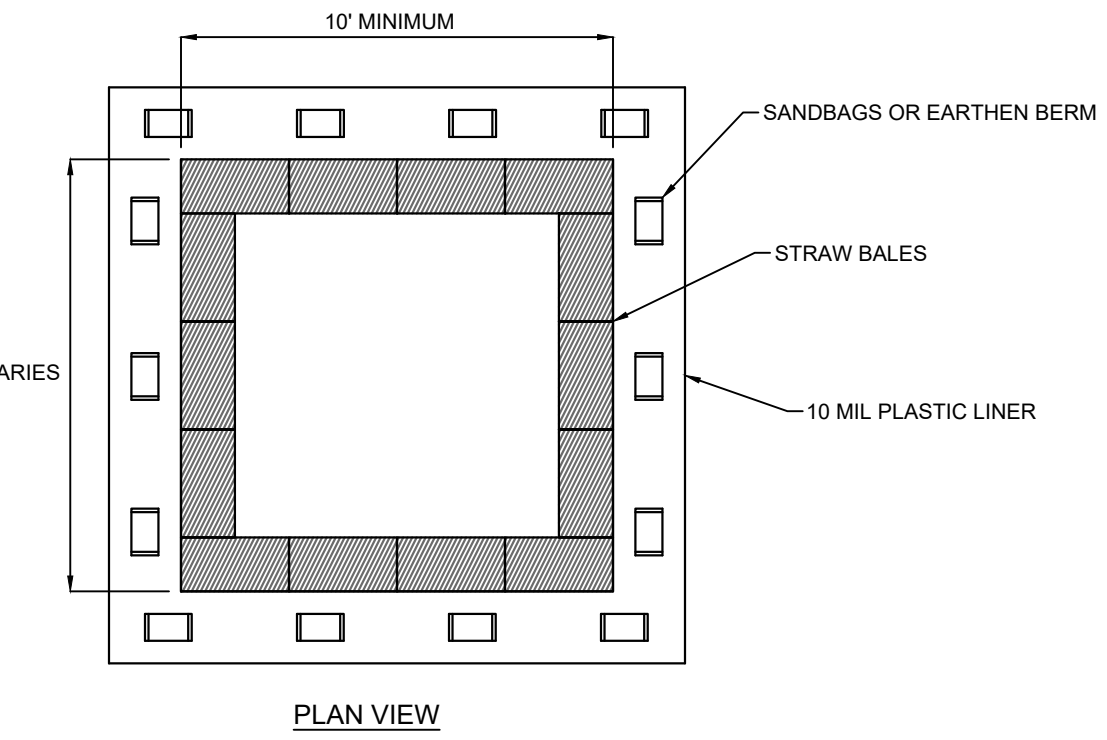

NOTES:
1. WASHOUT CONTAINMENT SHALL BE INSTALLED FOR DURATION OF CONCRETE WORK AND RETAIN CONCRETE AND OTHER WASHOUT LIQUIDS UNTIL EVAPORATION OR REMOVAL BY PUMP.
2. CONTAINMENT SHALL BE SIZED FOR EXPECTED WASHOUT VOLUMES.
3. AVOID PLACING NEAR STORM DRAINS, STREAMS, SINKHOLES, OUTFALLS OR OTHER LOW AREAS WHERE WATER PONDS OR FLOWS.
4. OTHER APPROVED LEAK-PROOF CONTAINMENT IS ACCEPTABLE.
5. TRAPS SHALL BE ROUTINELY MAINTAINED AT 75% CAPACITY AND REPLACED AS NECESSARY TO PERFORM.
6. THE WASHOUT PIT SHALL BE COVERED BEFORE PREDICTED RAIN EVENTS TO PREVENT OVERFLOW.
7. THE CONCRETE WASHOUT SIGN SHALL BE INSTALLED WITHIN 30FT OF THE TEMPORARY CONCRETE WASHOUT FACILITY.

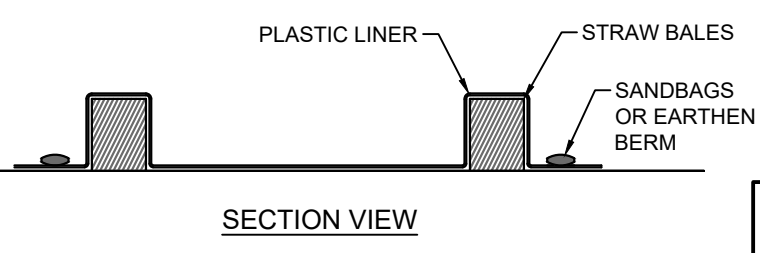

CONCRETE WASHOUT

SCALE: NONE

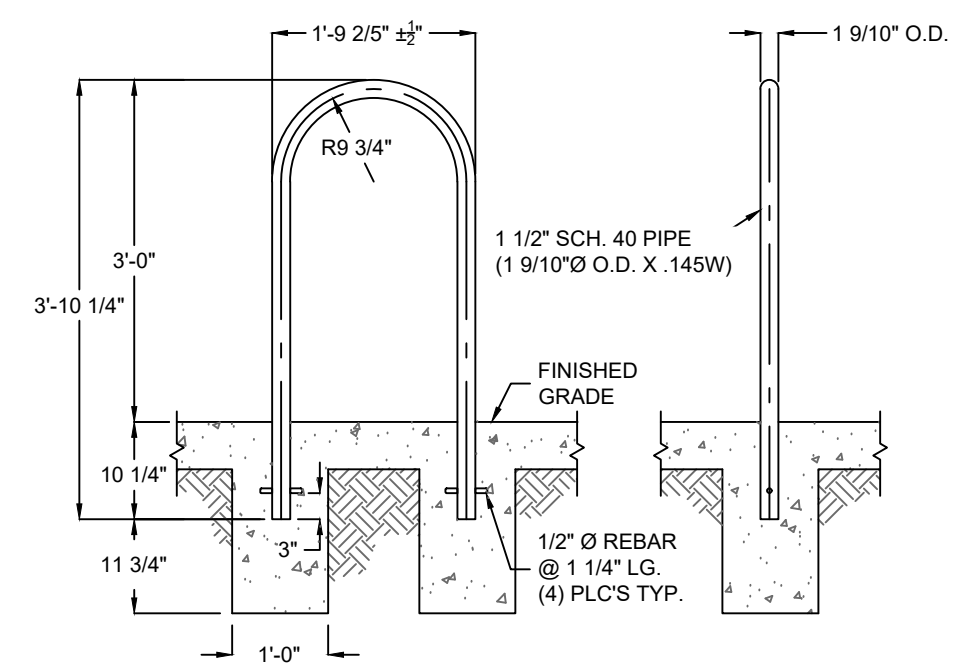

BICYCLE RACK

SCALE: NONE

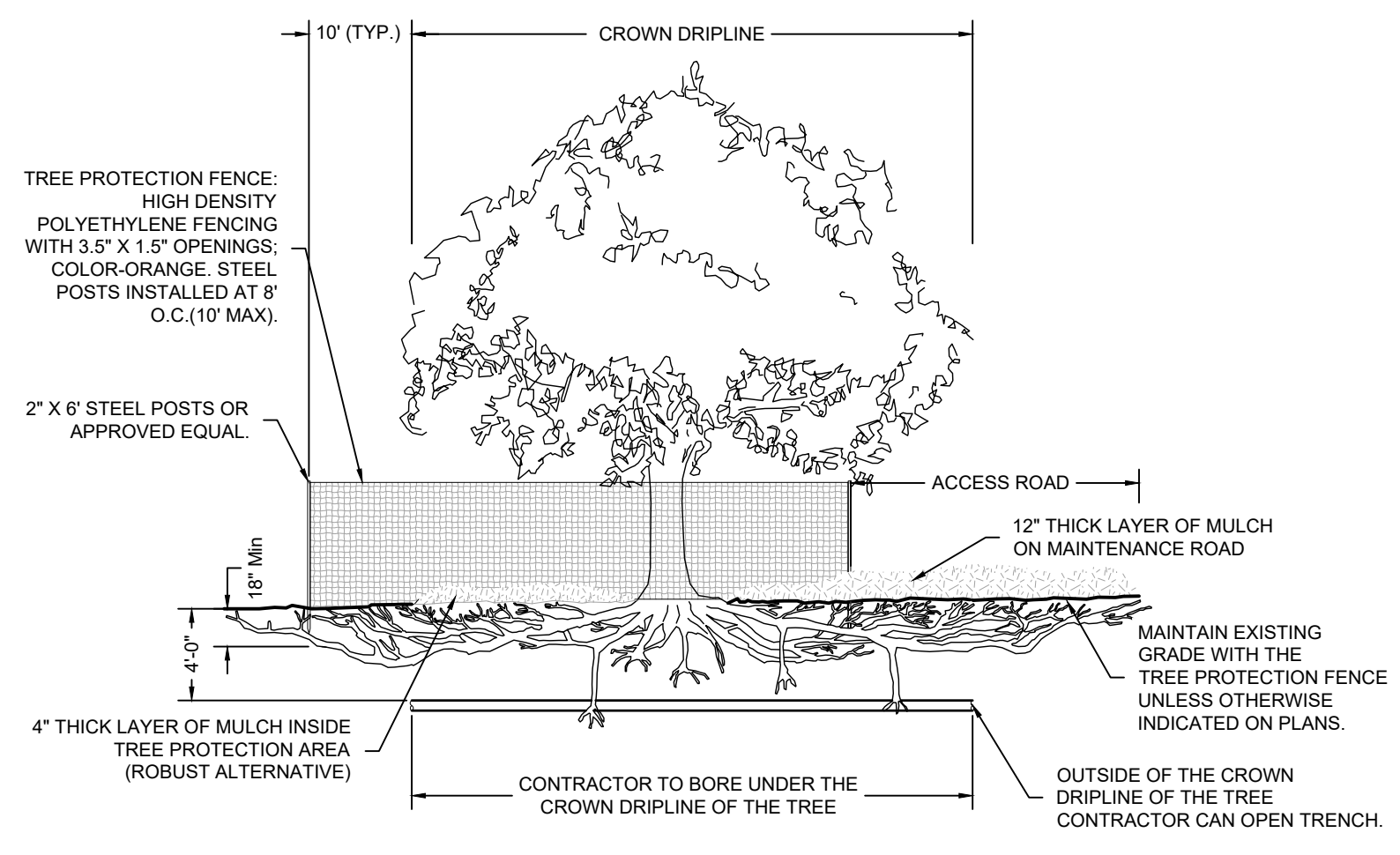

NOTES:
1. MAINTAIN TREE PROTECTION FENCING 10' BEYOND DRIPLINE (IN ALL DIRECTIONS).
2. NO EQUIPMENT, MATERIALS, AND/OR DEBRIS SHALL BE STORED WITHIN THE TREE PROTECTION FENCING. THIS INCLUDES DURING FENCE INSTALLATION AND REMOVAL.
3. NO PRUNING SHALL BE PERFORMED EXCEPT BY OR IN THE PRESENCE OF AND APPROVED ARBORIST.
4. IF PROJECTION REQUIRES AN ACCESS ROAD WITHIN THE DRIPLINE OF A TREE, PROVIDE A MINIMUM 12" OF MULCH FOR THE ACCESS ROAD.
5. IF CONSTRUCTION ACTIVITIES REQUIRE WORK TO CROSS THE DRIPLINE, BORE MINIMUM 4" BELOW GROUND SURFACE THE DISTANCE OF THE DRIPLINE, IF BORING 4" CANNOT BE ACHIEVED CONTACT ARBORIST IMMEDIATELY TO MONITOR WORK.

ROOT PRUNING NOTES:
1. ROOT PRUNING SHOULD BE COORDINATED WITH THE TREE PROTECTION FENCING. IN SOME CASES, THAT FENCE LINE IS ON THE ROOT CUT, AND PROVISIONS FOR ROOT PRUNING MAY NEED TO BE ACCOMMODATED BEFORE FENCE IS ERRECTED.
2. CAREFULLY EXPOSE ROOTS WITHIN THE LIMITS OF CONSTRUCTION AND MARK FOR PRUNING. PROPOSED ROOT CUTS SHALL BE REVIEWED BY AND ARBORIST PRIOR TO TRENCHING, EXCAVATING, OR CUTTING TO DETERMINE THE IMPACT ON ANY STRUCTURAL CRITICAL ROOTS AND THE CLOSEST POINT TO THE TREES THAT SOIL MAY BE DISTURBED.
3. ROOT PRUNING CAN BE ACCOMPLISHED WITH CIRCULAR SAWS OF VARYING TYPES AND/OR A ROTARY-TYPE STUMP GRINDER TO A DEPTH OF 18" OR TO THE MAXIMUM DEPTH OF THE REQUIRED GRADING CUT, WHICHEVER IS LESS. SAW BLADE AND GRINDER TEETH SHOULD BE SHARPENED PRIOR TO USE. TRENCHING MACHINES ARE NOT ALLOWED IN ROOT PRUNING OPERATIONS.
4. ROOTS OVER 1-INCH IN DIAMETER MUST BE CLEANLY AND SHARPLY CUT WITH HAND SAW.
5. PRUNING CUTS SHOULD BE FLUSH WITH THE SIDE OF THE TRENCH CLOSEST TO THE TREE. AN ARBORIST SHOULD REVIEW AND ROOTS OVER 2-INCHES IN DIAMETER ENCOUNTERED DURING EXCAVATION AND/OR CONSTRUCTION ACTIVITIES TO DETERMINE STRUCTURAL STABILITY OF THE TREE.

TREE PROTECTION FENCING

SCALE: NONE

TOH & ASSOCIATES
1550 E. REPUBLIC ROAD
SPRINGFIELD, MO 65804
Ph: 417-888-0645 Fax: 417-888-0657
www.tohassociates.com
COA: MO# E-200404242-D
© 2023 Toth and Associates, Inc.

C7.2
DETAILS

DATE: MAY 2, 2023

KINETIC
DESIGN + DEVELOPMENT
2101 W. CHESTERFIELD BLVD. SUITE A 101 · SPRINGFIELD, MO 65807 · P. (417) 530-4321
ARCHITECTURAL CORPORATION MISSOURI LICENSE NUMBER: A-201001427

ENGINEER OF RECORD:
NAME: SHAWN W. BARRY
LICENSE NO. MO #PE-2009010153

PROJECT NUMBER:
23031-7BOM2
REVISION:
07-10-2023 CITY REVIEW COMMENTS

7 BREW COFFEE
O'FALLON, MO #2
3600 MONTICELLO DR.
O'FALLON, MO 63304