

ISSUE	REMARKS/DATE
1	INITIAL SUBMITTAL
2	9-23-20 Rev Duckett Creek Cmmnt
3	20201001 Rev per City/Duckett/PWSD#2
4	20201014 Rev per Duckett
5	20201020 Rev per City Comments
6	20201102 Rev per DCSD Comments
7	20201106 Rev per City Comments
8	20210518 Rev per Developer
9	20210719 Rev per DCSD Comments

**DUCKETT CREEK ABANDONMENT NOTES:**

1. DUCKETT CREEK SANITARY DISTRICT (DCSD) INSPECTION, COORDINATION AND APPROVAL IS REQUIRED FOR REALIGNMENT AND ABANDONMENT OF EXISTING SANITARY SEWER MAIN. EXISTING SANITARY SEWER SERVICE SHALL NOT BE INTERRUPTED.
2. EXISTING SANITARY SEWER MAIN TO BE ABANDONED SHALL BE GROUT FILLED AND PLUGGED AT EACH TERMINUS OF ABANDONED PIPE.
3. EXISTING SANITARY MANHOLES TO BE ABANDONED SHALL BE REMOVED.

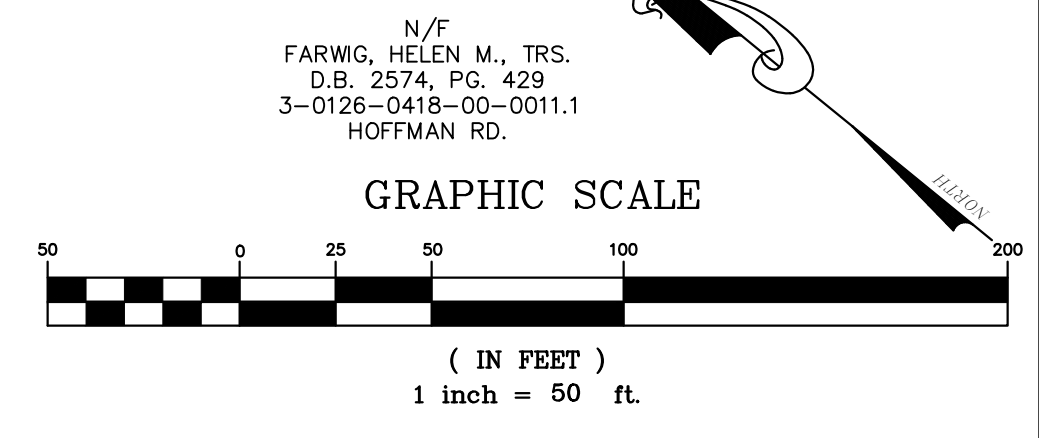

THE UNDERGROUND UTILITIES SHOWN HEREON WERE PLOTTED FROM AVAILABLE INFORMATION AND DO NOT NECESSARILY REFLECT THE ACTUAL EXISTENCE, NONEXISTENCE, SIZE, TYPE, NUMBER OR LOCATION OF THESE OR OTHER UTILITIES. THE GENERAL CONTRACTOR SHALL BE RESPONSIBLE FOR VERIFYING THE ACTUAL LOCATION OF ALL UNDERGROUND UTILITIES, SHOWN OR NOT SHOWN, AND SAID UTILITIES SHALL BE LOCATED IN THE FIELD PRIOR TO ANY GRADING, EXCAVATION OR CONSTRUCTION OF IMPROVEMENTS. THESE PROVISIONS SHALL IN NO WAY ABSOLVE ANY PARTY FROM COMPLYING WITH THE UNDERGROUND FACILITY SAFETY AND DAMAGE PREVENTION ACT, CHAPTER 319, RSMo

**NOTE:**  
SEE SEPARATE SWPPP AND ROUGH GRADING PLANS DATED 6-23-2020 FOR SEDIMENT AND EROSION CONTROL DESIGN AND DETAILS.

**PROJECT TITLE**  
**AMBERLEIGH**  
OF FALLON, MISSOURI

**THE STERLING CO.**  
**ENGINEERS & SURVEYORS**  
5055 New Baumgartner Road  
St. Louis, Missouri 63129  
Ph 314-487-0440 Fax 314-487-8944  
www.sterling-eng-survey.com  
Corporate Certificate of Authority #001348

Date: 8-27-2021  
Jason D Howell  
License No. PE 2007002801  
Professional Engineer

**LOMBARDO HOMES OF ST. LOUIS, LLC**  
2299 TECHNOLOGY DRIVE, SUITE 150  
OF FALLON, MISSOURI 63368  
Ph 636-265-2710  
Fax 636-695-3195

**SITE PLAN**

P+Z No. 20-000028  
City No. 20-003192  
Date: Aug. 27, 2021  
Job No. 14-04-136  
Page No. **4.6**

IMP