

PROVIDE 1/2" REINFORCED EXPANSION JOINT FILLER AT 8' CENTERS PROVIDE TOoled CONTRACTION JOINTS AT 10' C.C.

TURNED DOWN CONCRETE WALK
NOT TO SCALE

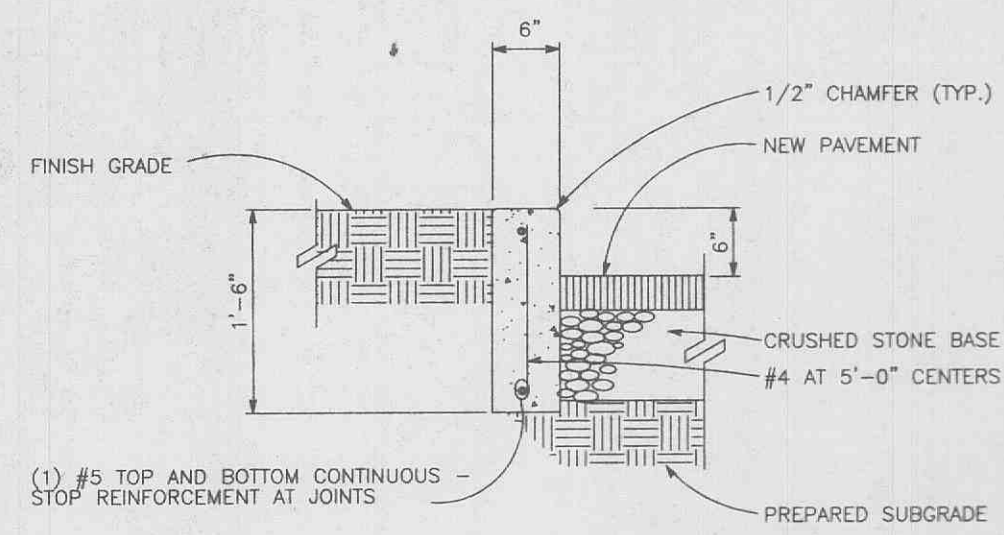

CONCRETE CURB DETAIL
NOT TO SCALE

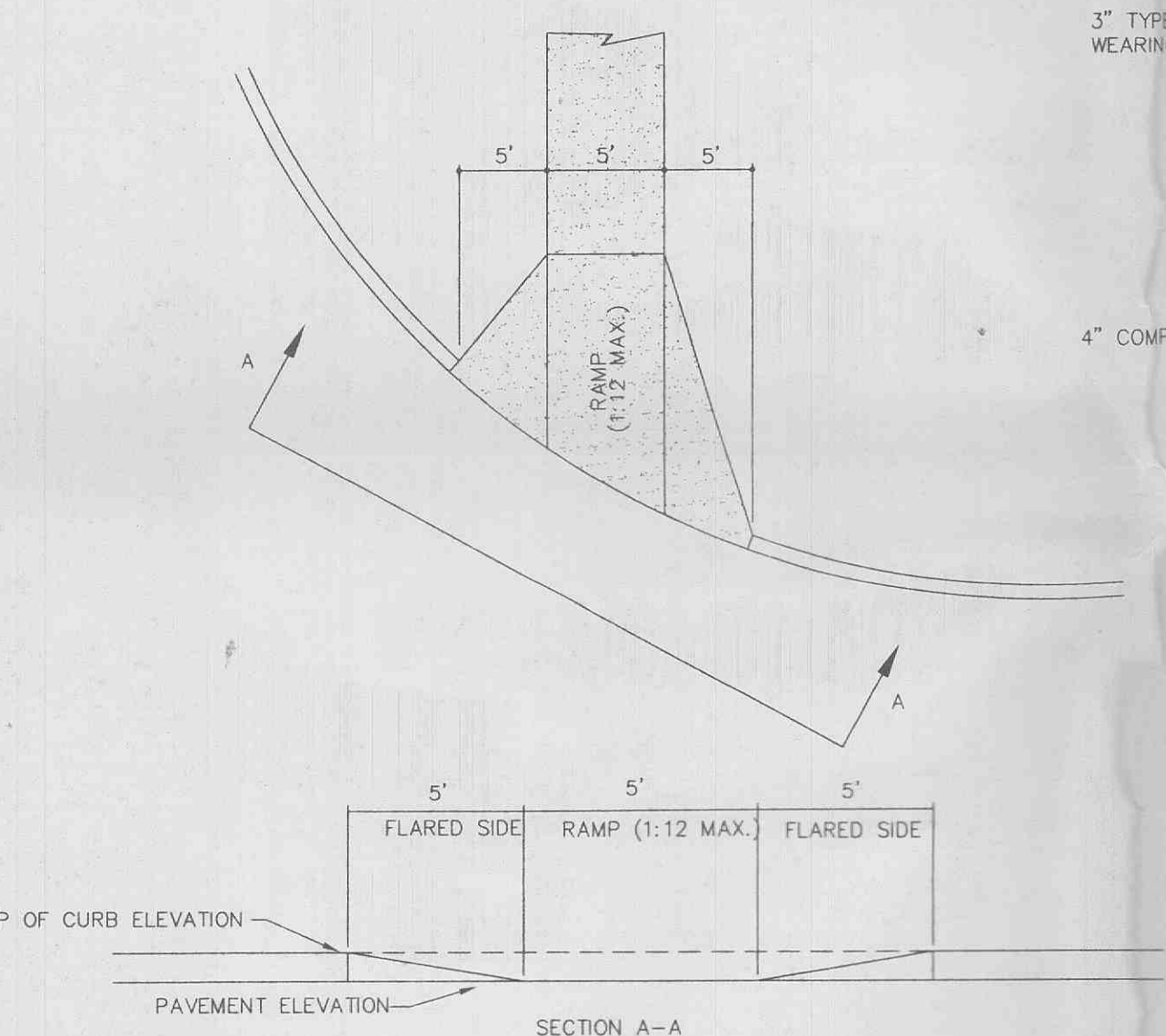

HANDICAPPED RAMP DETAIL
NOT TO SCALE

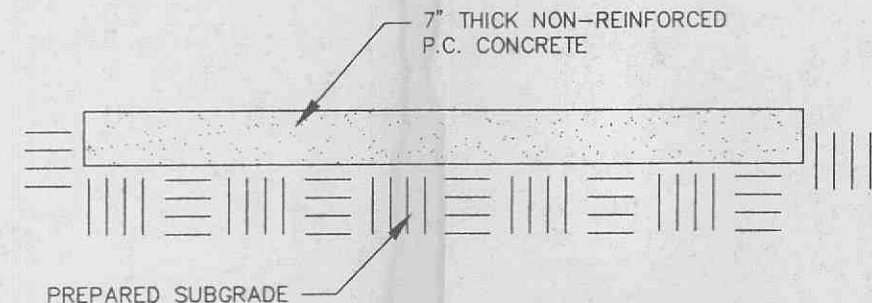

CONCRETE PAVEMENT DETAIL
NOT TO SCALE

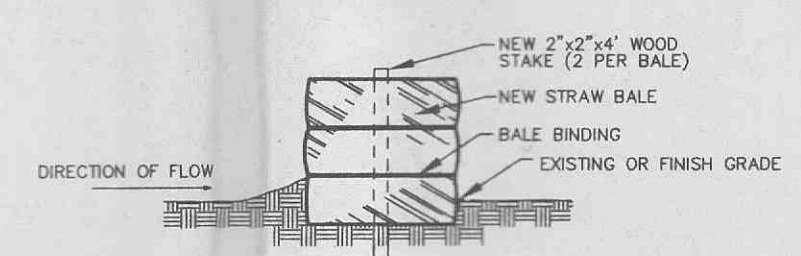

NOTES:
1. STRAW BALES, NOT HAY BALES SHALL BE USED.
2. BUTT ENDS OF BALES TIGHTLY TOGETHER.
3. INSTALL BALES WITH BINDING AROUND SIDES, NOT TOP AND BOTTOM.
4. FILL ANY GAP BETWEEN BALES BY WEDGING LOOSE STRAW BETWEEN THEM.

SEDIMENT BARRIER
NOT TO SCALE

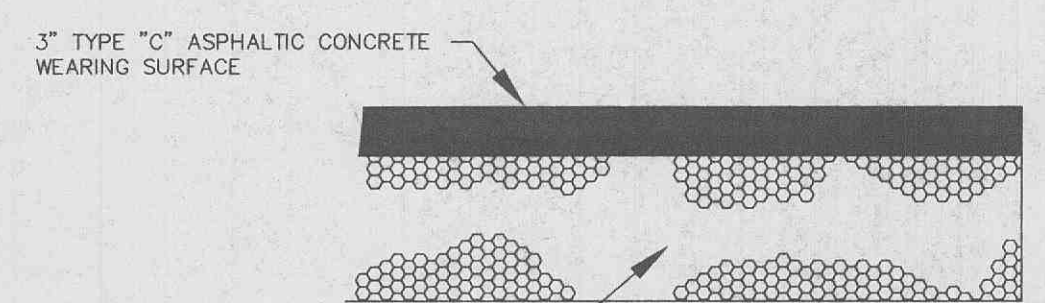

ASPHALT PAVEMENT DETAIL
NOT TO SCALE

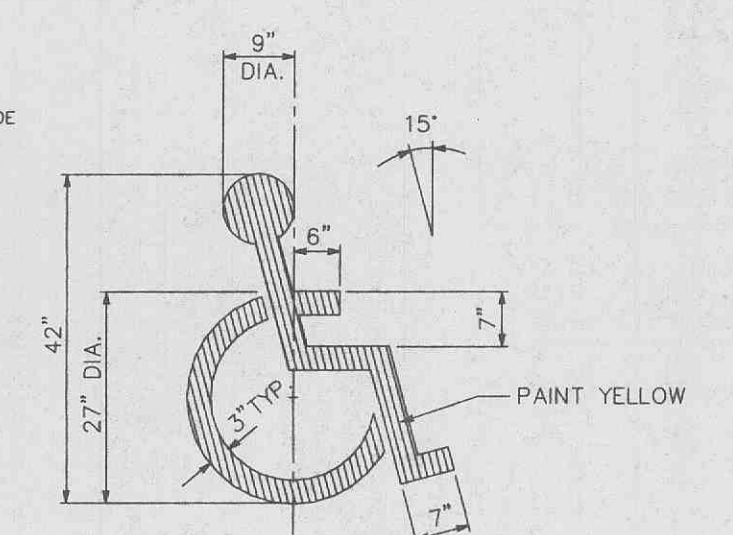

PAINTED HANDICAPPED PARKING SYMBOL
NOT TO SCALE

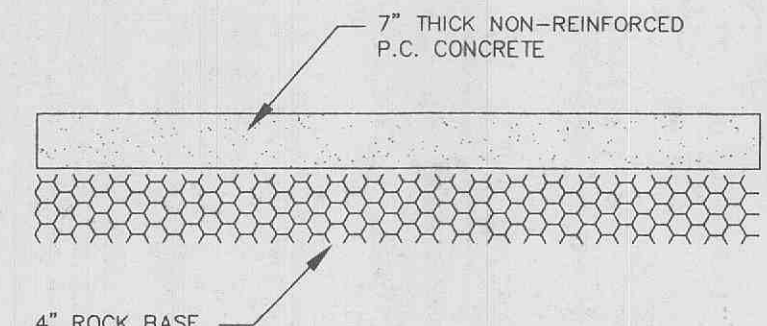

PAVEMENT ENTRANCE DETAIL
NOT TO SCALE

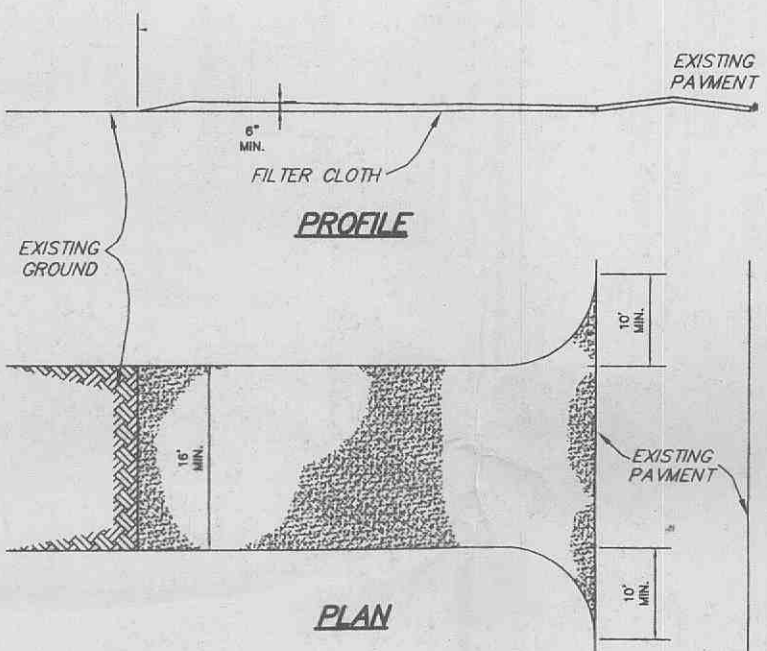

STABILIZED CONSTRUCTION ENTRANCE/WASHDOWN AREA
NOT TO SCALE

- CONSTRUCTION SPECIFICATIONS**
- Stone Size - Use 2" stone, or reclaimed or recycled concrete equivalent.
 - Length - As required, but not less than 50 feet.
 - Thickness - Not less than six (6) inches.
 - Width - Twenty (20) foot minimum, but not less than the full width at points where ingress or egress occurs.
 - Filter Cloth - Will be placed over the entire area prior to placing of stone.
 - Surface Water - All surface water flowing or diverted toward construction entrances shall be piped across the entrance. If piping is impractical, a portable storm with 5:1 slopes will be permitted.
 - Maintenance - The entrance shall be maintained in a condition which will prevent tracking or flowing of sediment onto public rights-of-way. This may require periodic top dressing with additional stone as conditions demand and repair and/or cleanout of any measures used to trap sediment. All sediment spilled, dropped, washed or tracked onto public rights-of-way must be removed immediately.
 - Washing - Wheels shall be cleaned to remove sediment prior to entrance onto public rights-of-way. When washing is required, it shall be done on an area stabilized with stone and which drains into an approved sediment trapping device.
 - Periodic inspection and needed maintenance shall be provided after each rain.

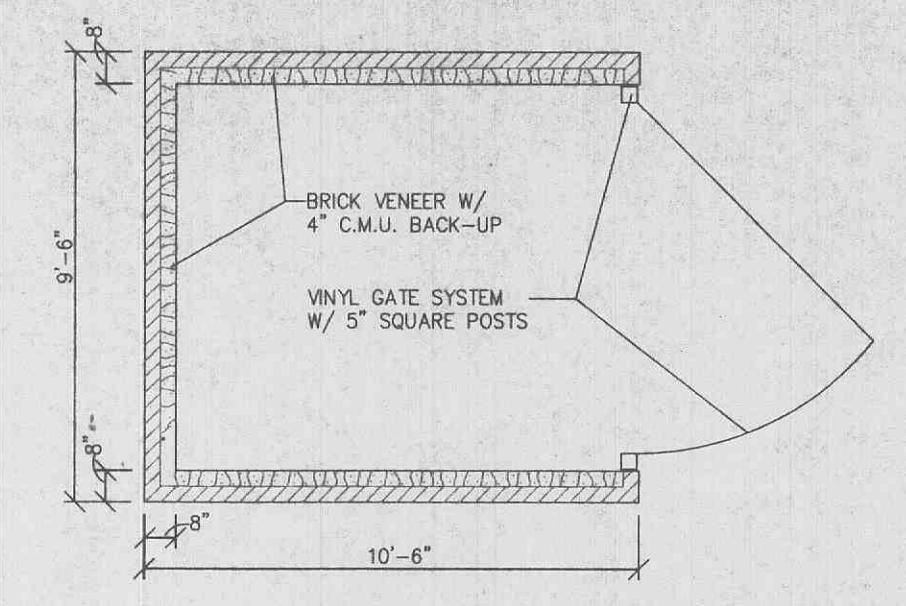

PLAN - TRASH ENCLOSURE
N.T.S.

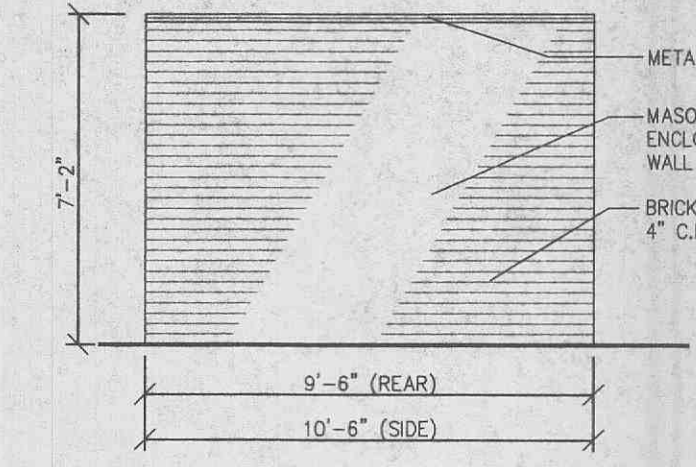

REAR & SIDE VIEW OF TRASH ENCLOSURE
N.T.S.

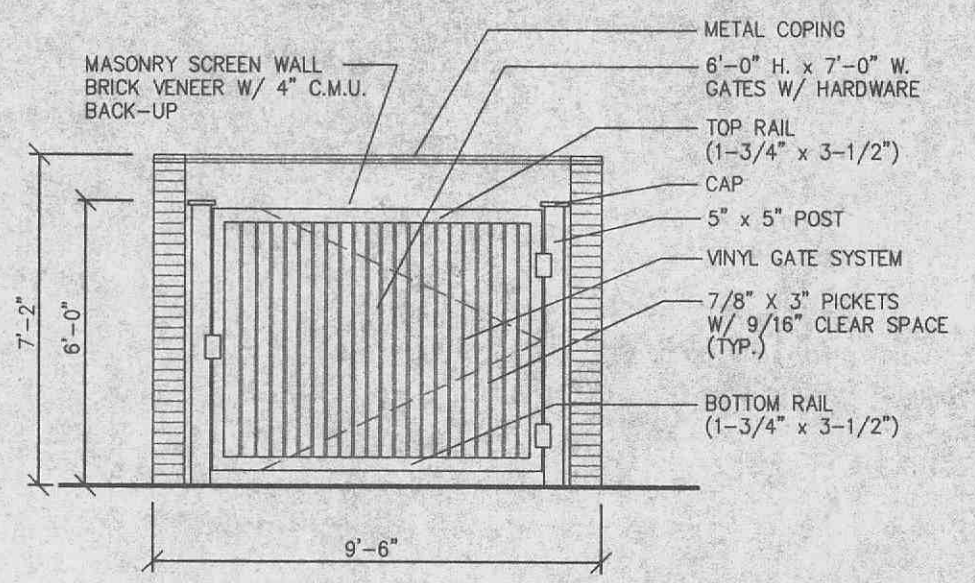

ELEV. AT TRASH ENCLOSURE GATE
N.T.S.

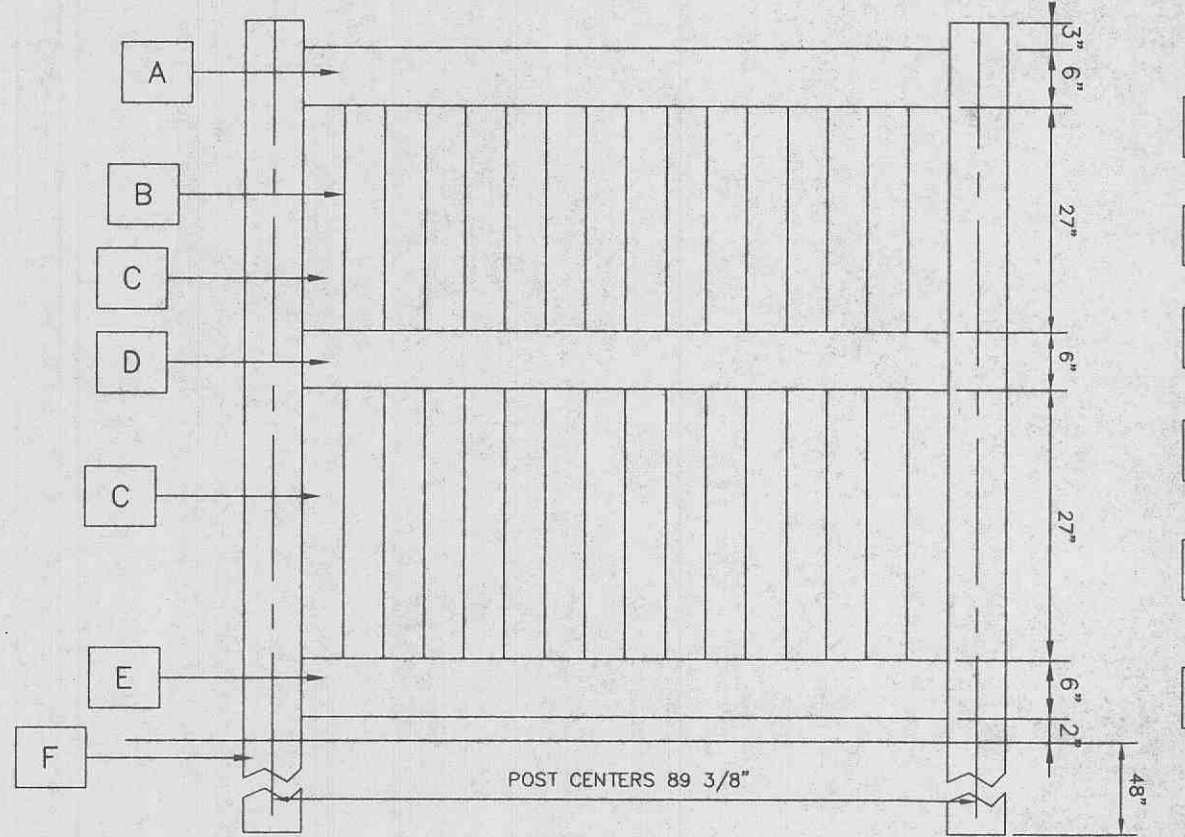

6' HIGH VINYL PRIVACY FENCE
NOT TO SCALE

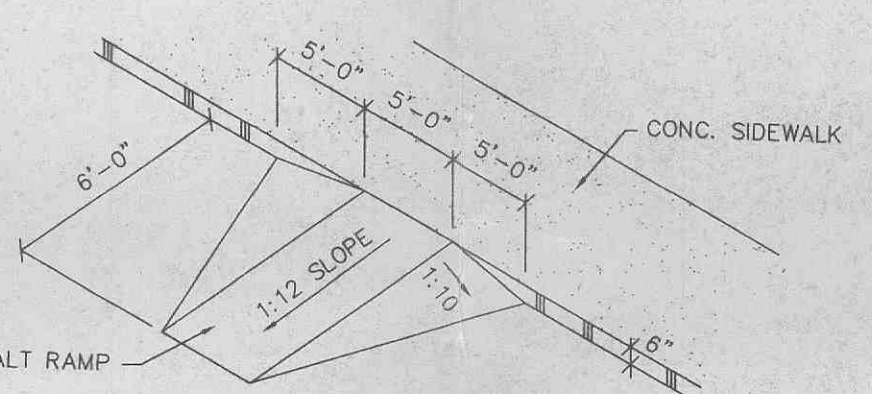

HANDICAPPED RAMP DETAIL
NOT TO SCALE

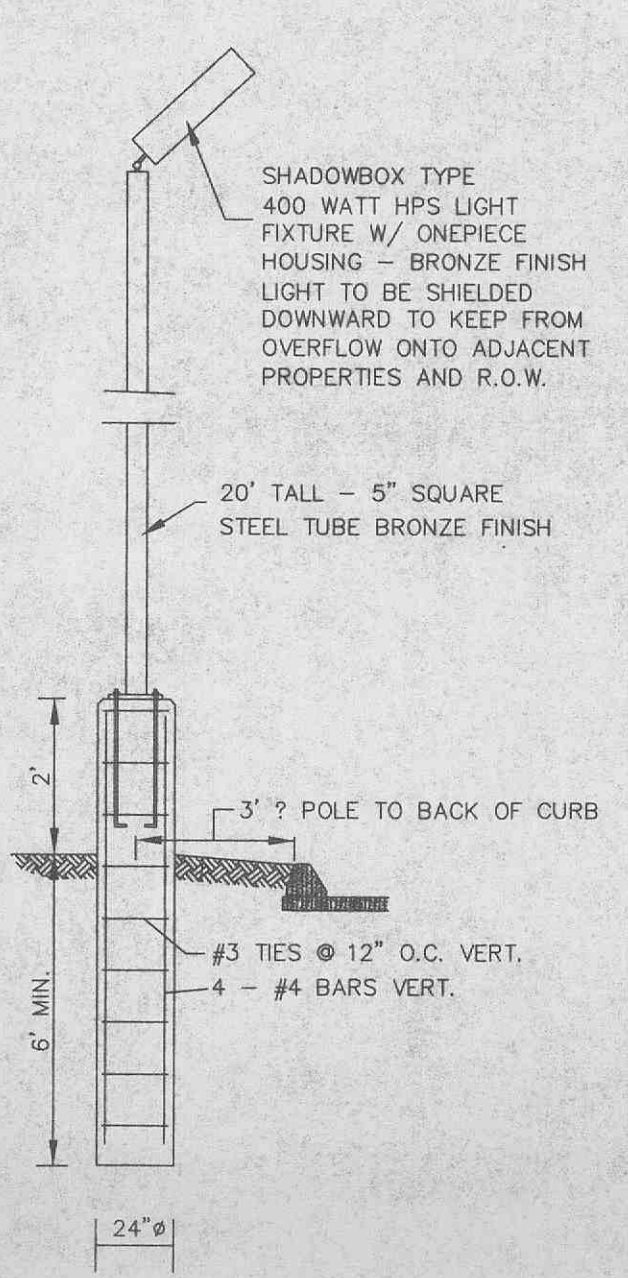

LIGHT POLE & BASE
NOT TO SCALE

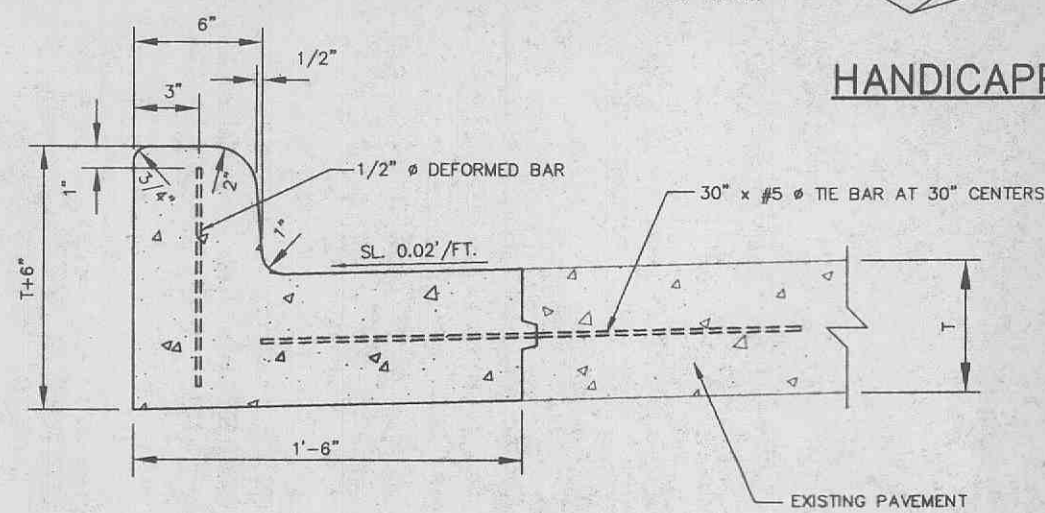

VERTICAL CONC. CURB & GUTTER (R/W)
NOT TO SCALE



HANDICAP PARKING ONLY
12" X 18" SIGN

STANDARD SIGN FACE, STANDARD HIGHWAY DEPARTMENT, OR CITY STREET DEPARTMENT GAUGE, BLACK OR BLUE LETTERING, GALVANIZED STEEL POST 9'-6" LONG, SET 3'-0" INTO GRADE, SET BOTTOM OF SIGN 5'-0" ABOVE FINISHED GRADE

HANDICAP PARKING SIGN

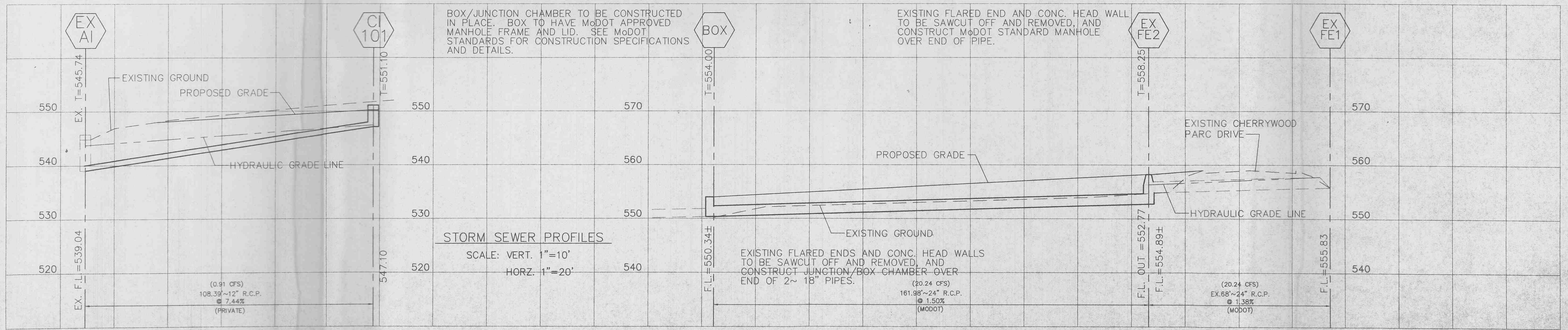

BOX/JUNCTION CHAMBER TO BE CONSTRUCTED IN PLACE. BOX TO HAVE MODOT APPROVED MANHOLE FRAME AND LID. SEE MODOT STANDARDS FOR CONSTRUCTION SPECIFICATIONS AND DETAILS.

EXISTING FLARED END AND CONC. HEAD WALL TO BE SAWCUT OFF AND REMOVED, AND CONSTRUCT MODOT STANDARD MANHOLE OVER END OF PIPE.

EXISTING FLARED ENDS AND CONC. HEAD WALLS TO BE SAWCUT OFF AND REMOVED, AND CONSTRUCT JUNCTION/BOX CHAMBER OVER END OF 2~ 18" PIPES.

PREPARED FOR: EARLL CONSTRUCTION, INC.
7410 EUGENE
ST. LOUIS, MO 63116
(314) 832-9090

DISCLAIMER OF RESPONSIBILITY
I hereby certify that the documents intended to be authenticated by my seal are limited to this sheet, and I hereby disclaim any responsibility for all other Drawings, Specifications, Estimates, Reports or other documents or instruments relating to or intended to be used for any part or parts of the architectural or engineering project of survey.

Copyright 1998
Earll Construction Company, Inc.
All Rights Reserved

REVISIONS	
8-14-00	REV. PER MODOT
8-31-00	REV. PER O'FALLON
9-12-00	REV. PER O'FALLON

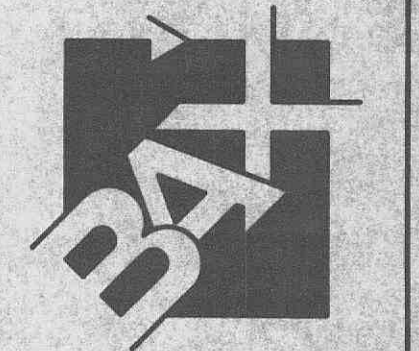

ENGINEERING
PLANNING
SURVEYING
1062 South Cloverleaf Drive
St. Peters, MO. 63376-6445
314-928-6552
FAX 928-1718

07/11/00
DATE
00-11057R
PROJECT NUMBER
3 OF 5
SHEET OF
11057CON.DWG
FILE NAME
END CLH
DRAWN CHECKED