

C:\civil\c8.dwg 08-16-00 05:31am
 DESIGN LEADER: DRAWN: CHECKED: SW-1.dwg 08-03-98 2:40pm =D98.02.16-SW-5401 © COPYRIGHT 1997

DIMENSION & TYPE

Concrete Section	A	B	C
Drive Aisle	5"	4"	
Loading/Dumpster	6"	4"	
Approaches	6"	4"	

4 CONCRETE PAVING SECTION

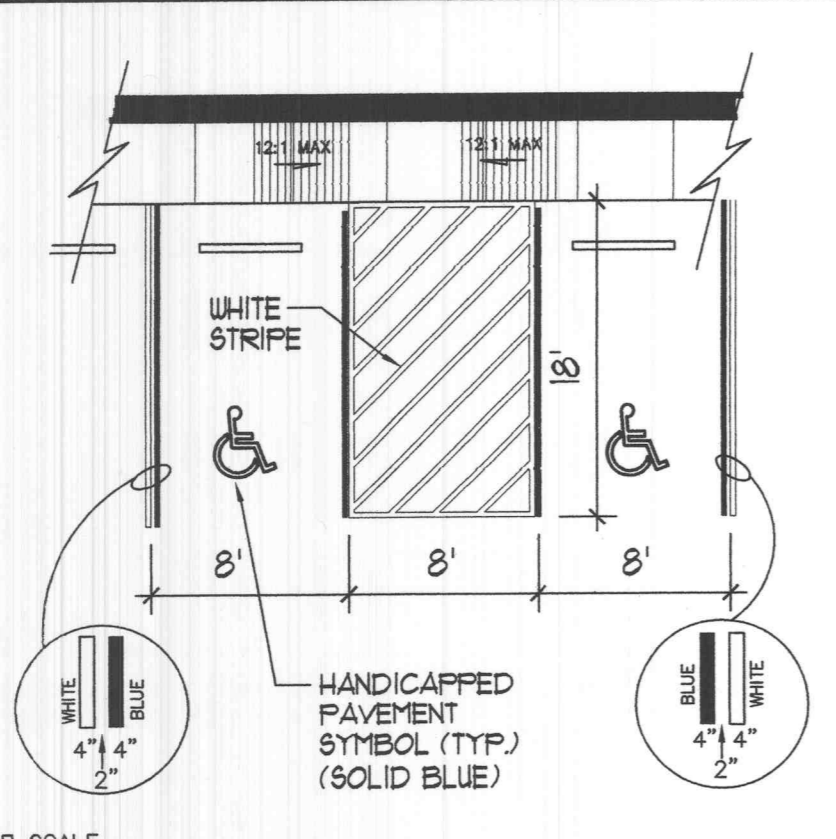

6 HANDICAP PARKING DETAIL

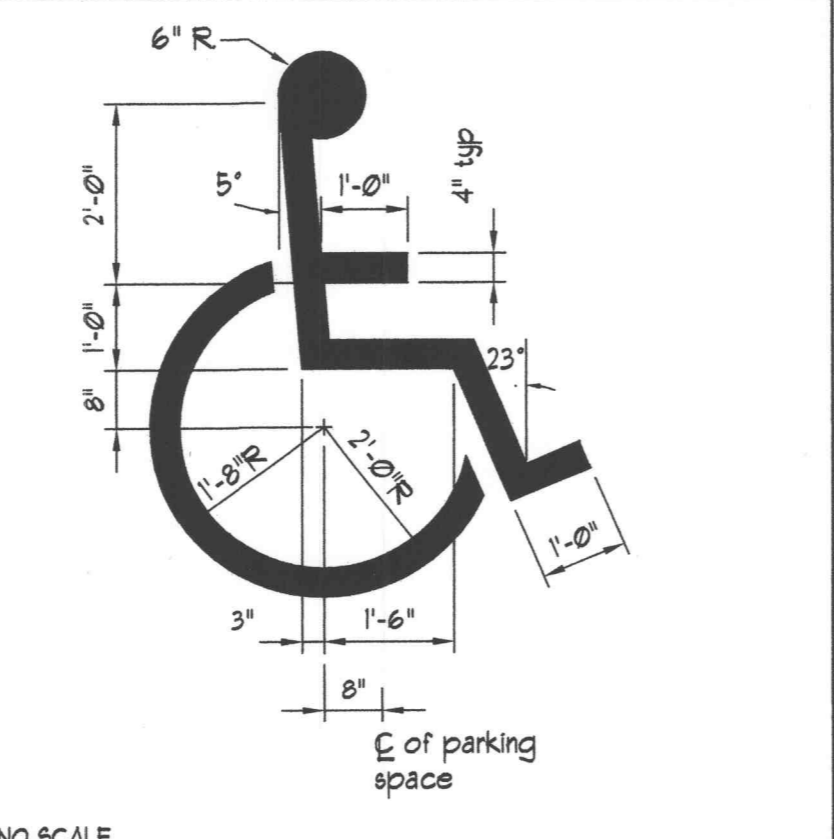

7 INT'L BARRIER FREE SYMBOL

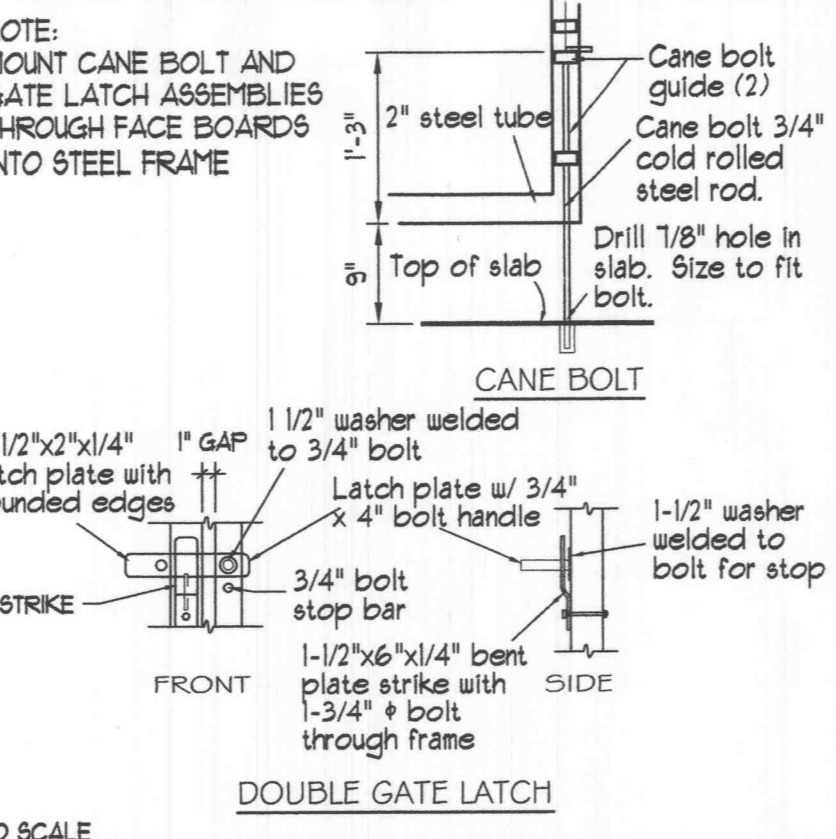

12 GATE LATCH / BOLT DETAILS

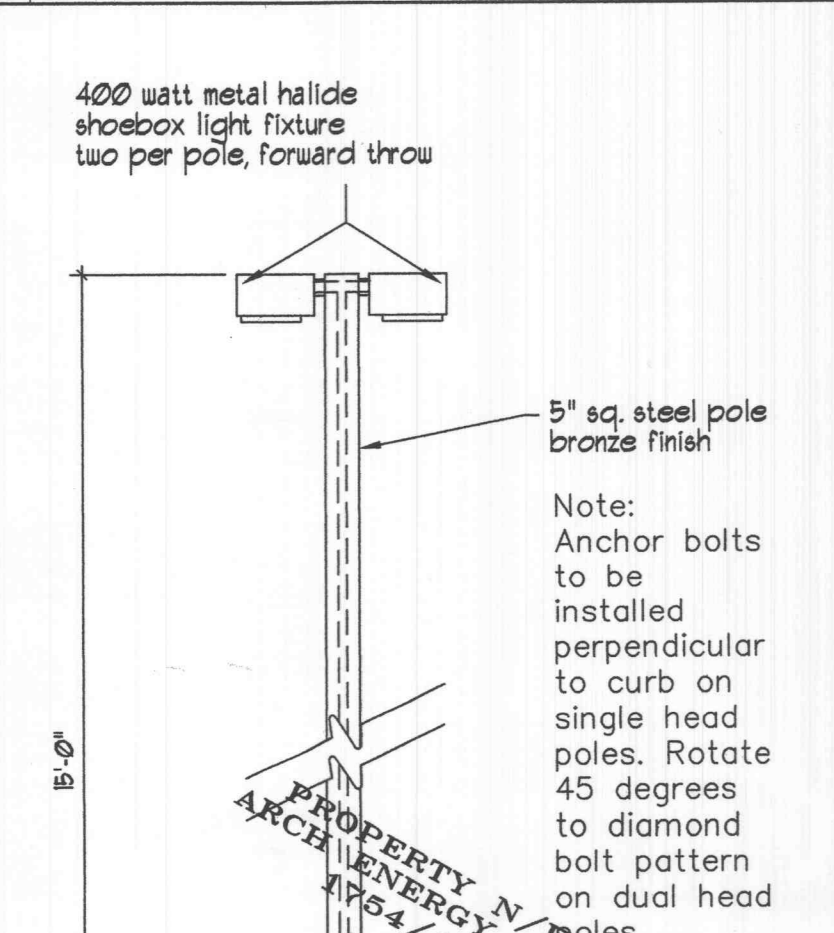

8 TYPICAL LIGHT POLE

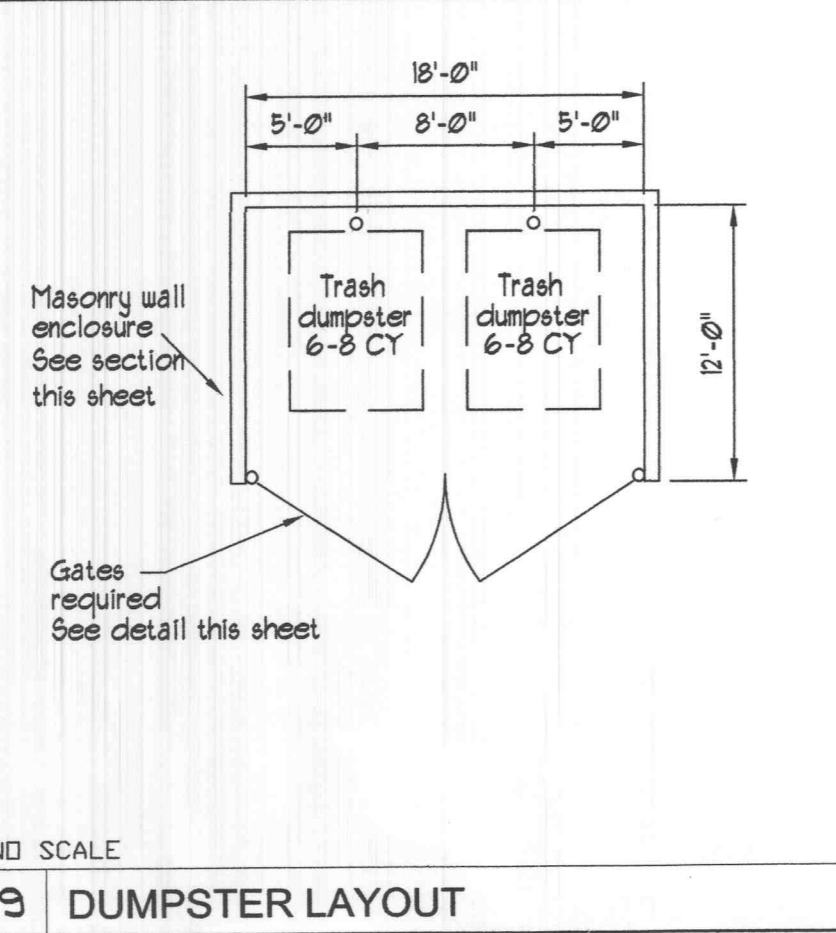

9 DUMPSTER LAYOUT

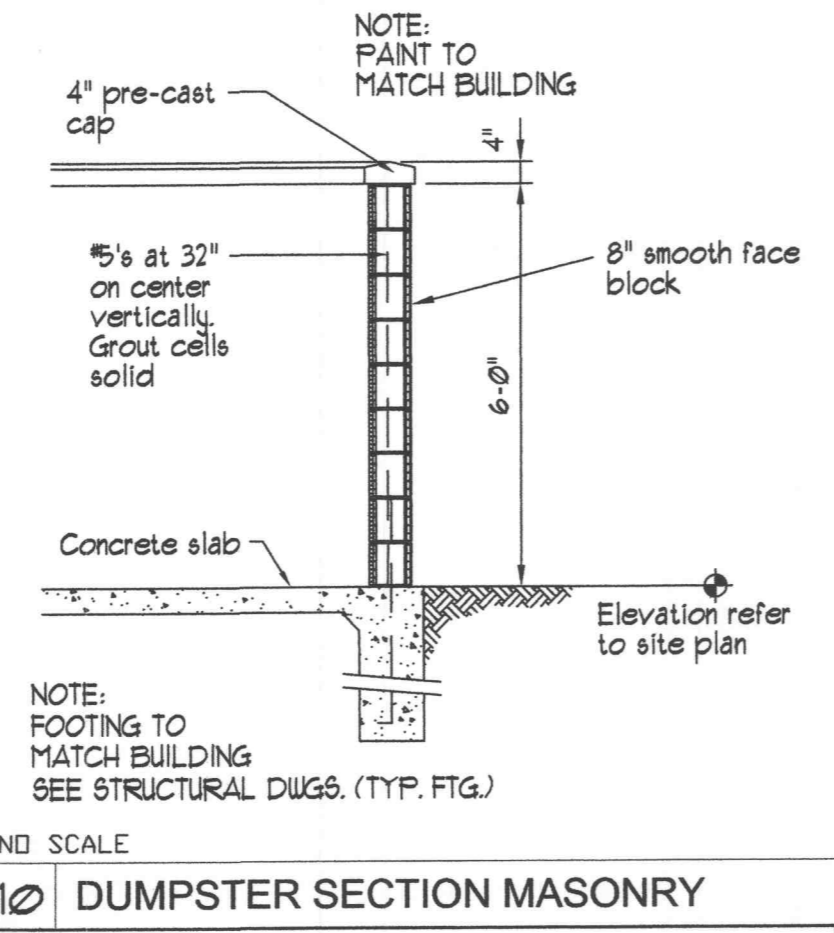

10 DUMPSTER SECTION MASONRY

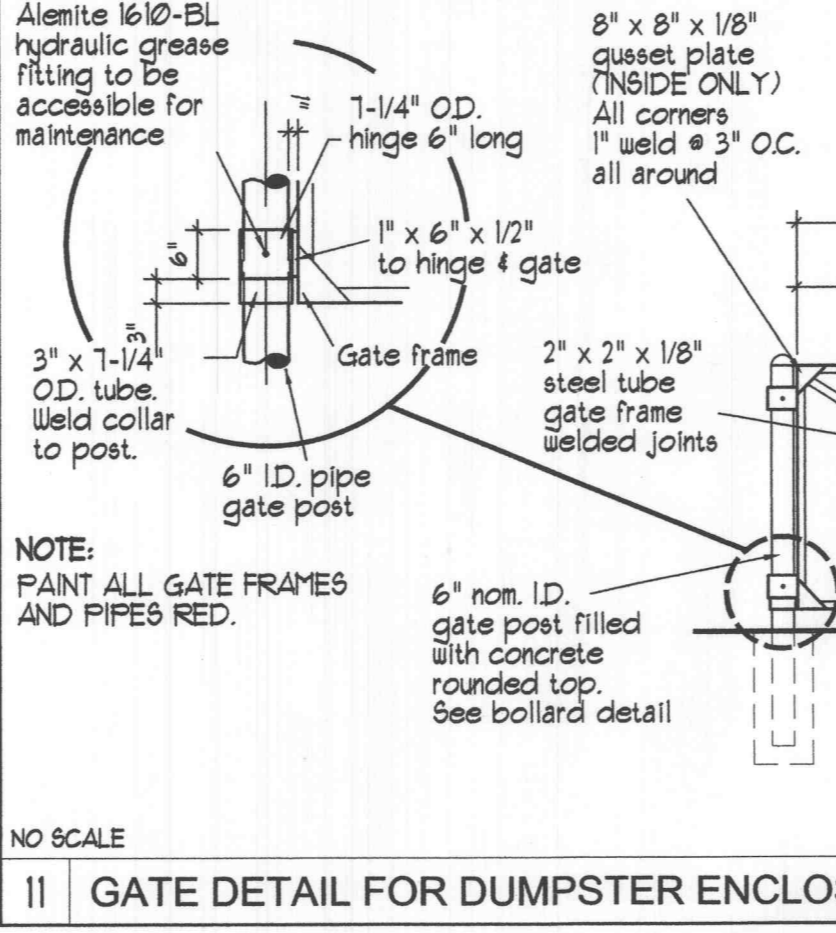

11 GATE DETAIL FOR DUMPSTER ENCLOSURE

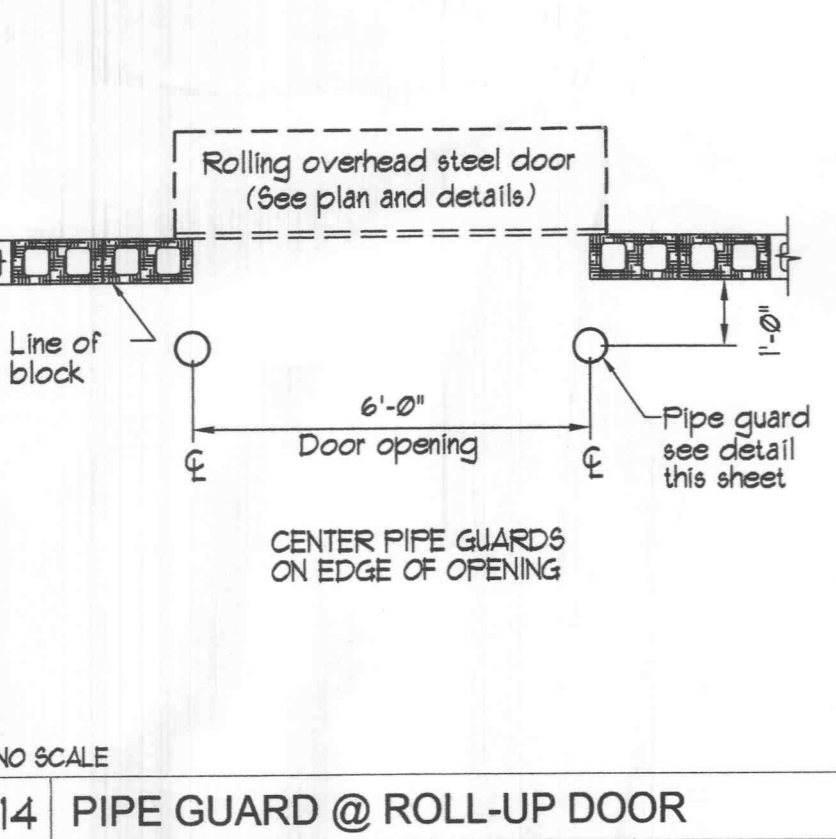

14 PIPE GUARD @ ROLL-UP DOOR

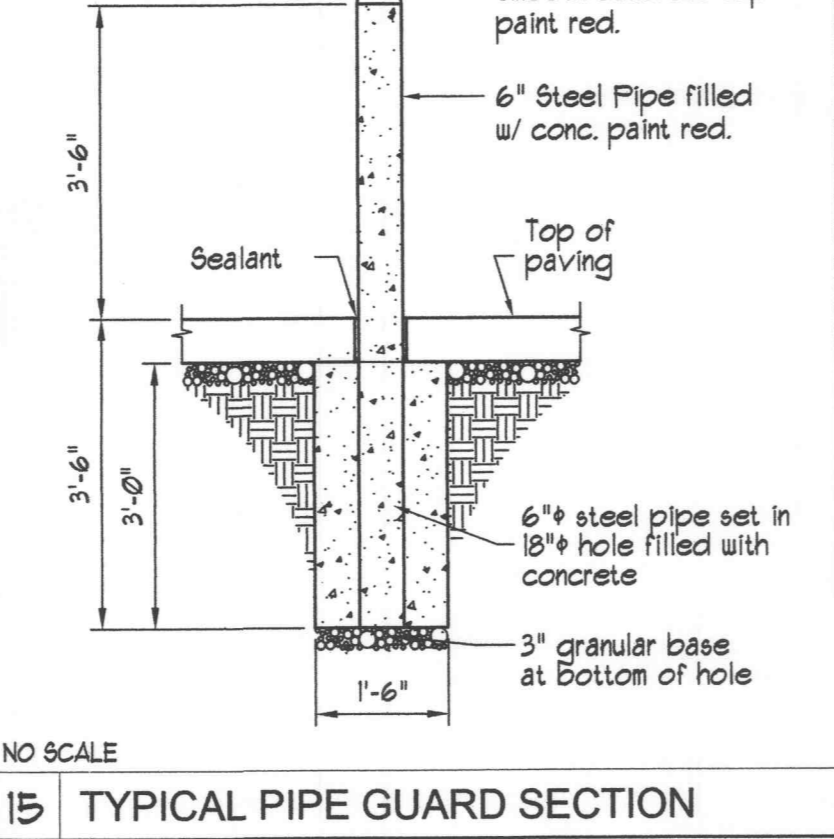

15 TYPICAL PIPE GUARD SECTION

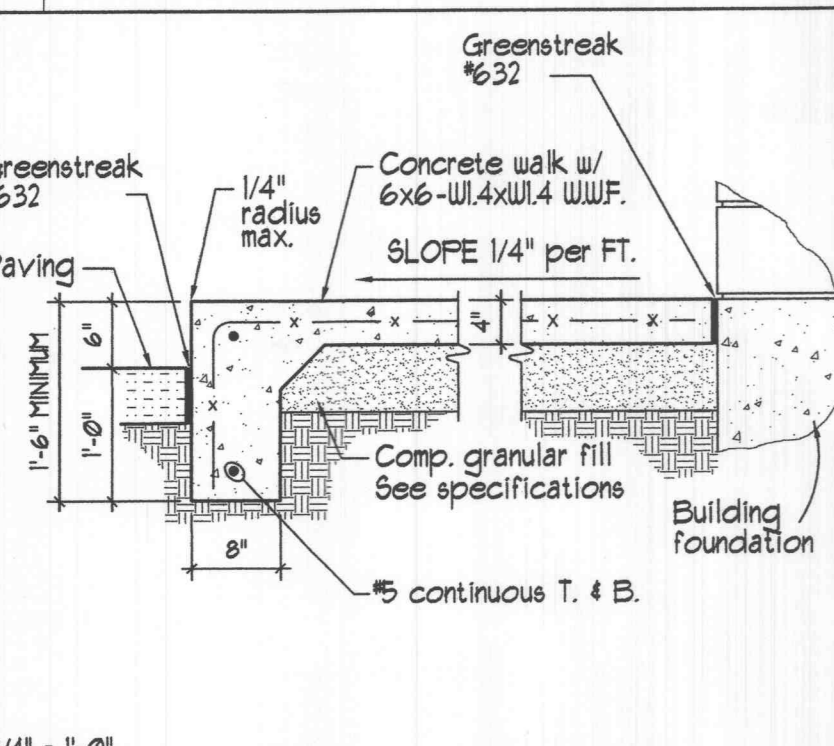

17 TYPICAL WALK SECTION

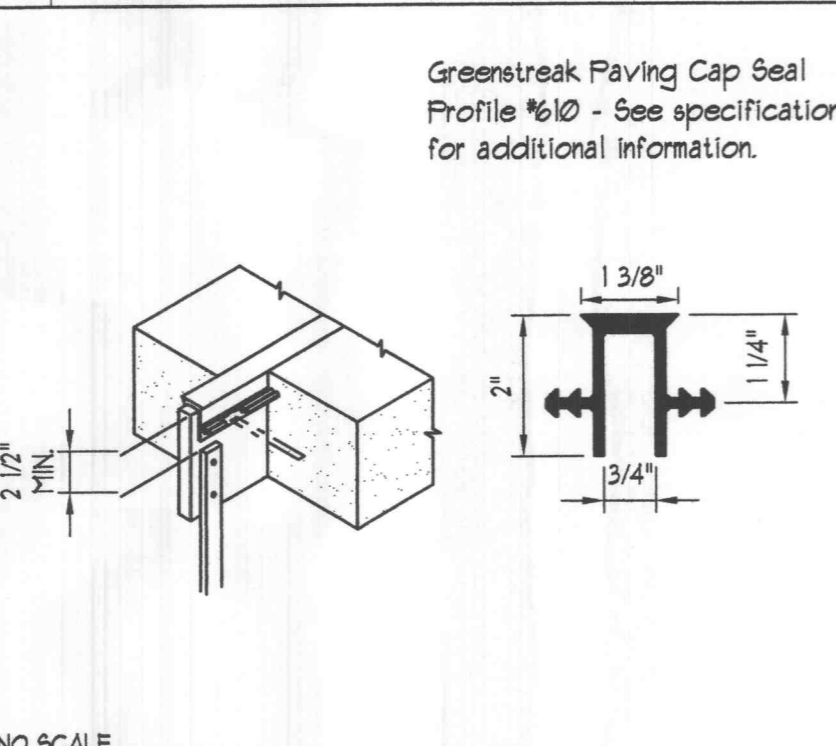

18 TYPICAL EXPANSION JOINT

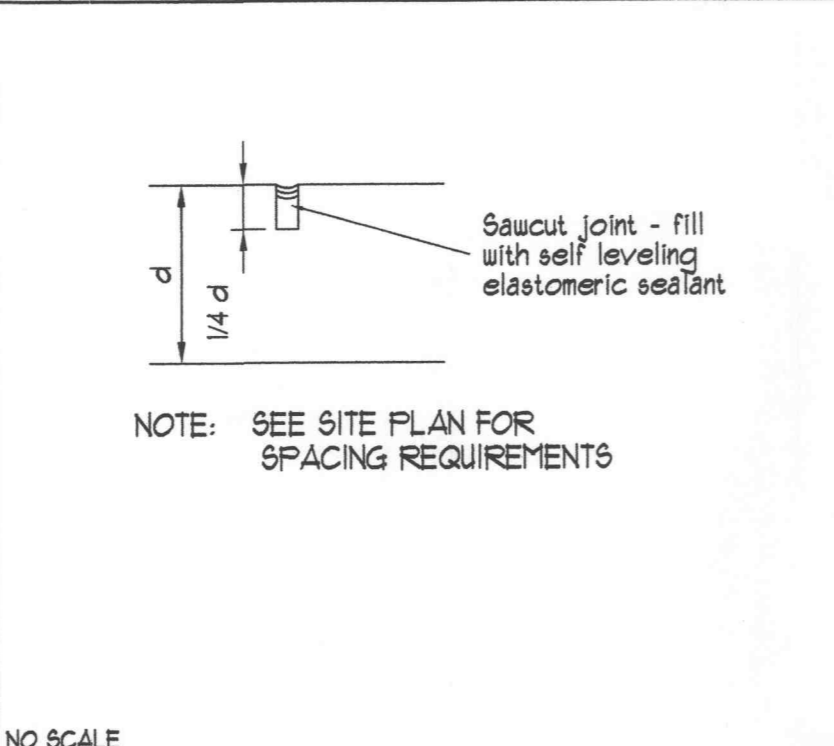

19 TYPICAL CONTROL JOINT

AUTOZONE
 123 South Front Street 3rdFloor
 Memphis, Tennessee 38103
 TEL: (901) 495-8759 FAX: (901) 495-8969

AutoZone STORE DEVELOPMENT
 STORE NO.2064
 MISSOURI STATE HIGHWAY "N"
 OFALLON MO 63366

SITE DETAIL SHEET

REVISIONS

1.	
2.	
3.	
4.	

SCALE: 1" = 20'

DATE
 05-28-04

PROTOTYPE SIZE
 7N2-RIGHT

C8