

1 CASEWORK SECTION

A6.5 1 1/2" = 1'-0"

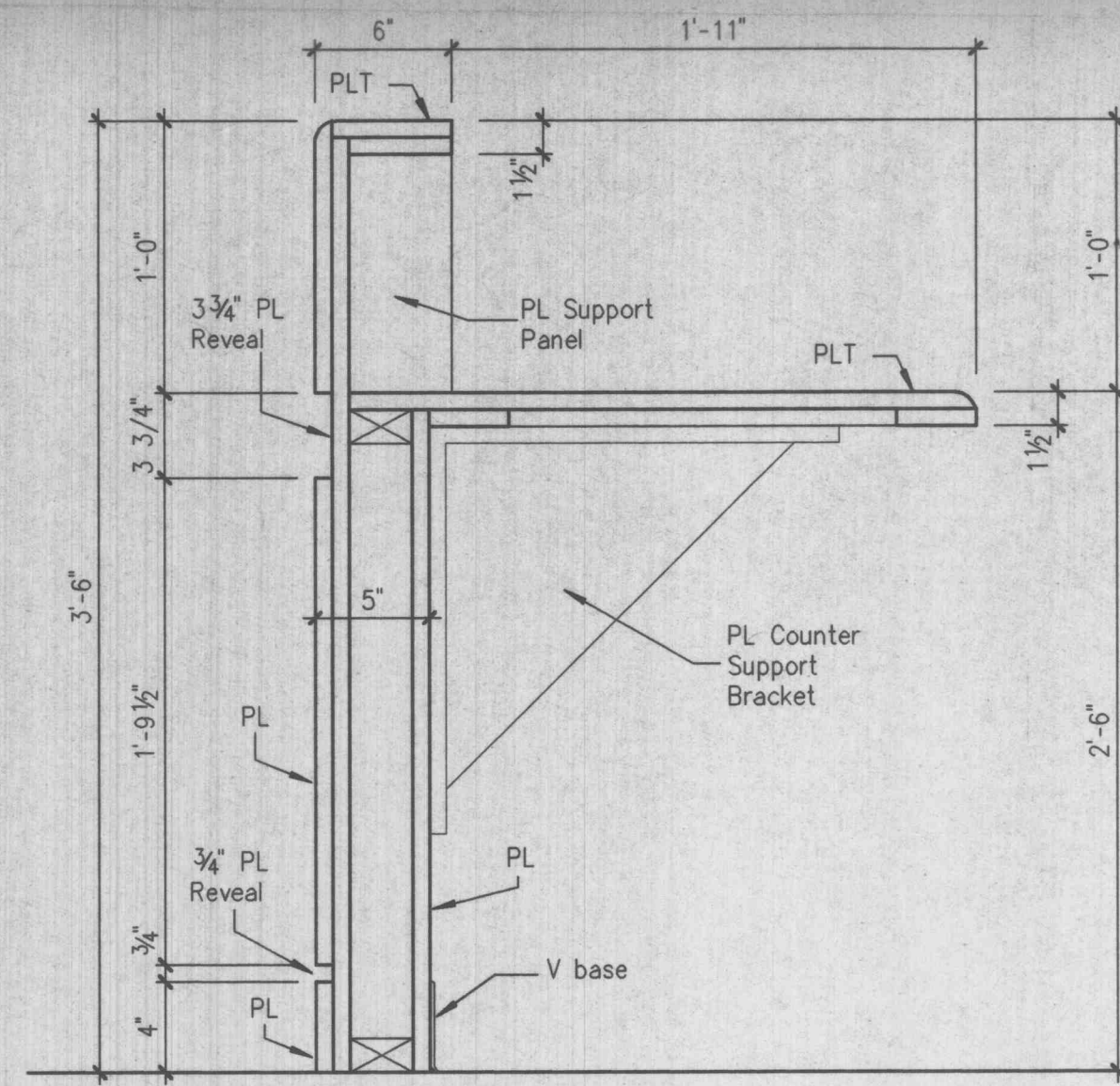

2 CASEWORK SECTION

A6.5 1 1/2" = 1'-0"

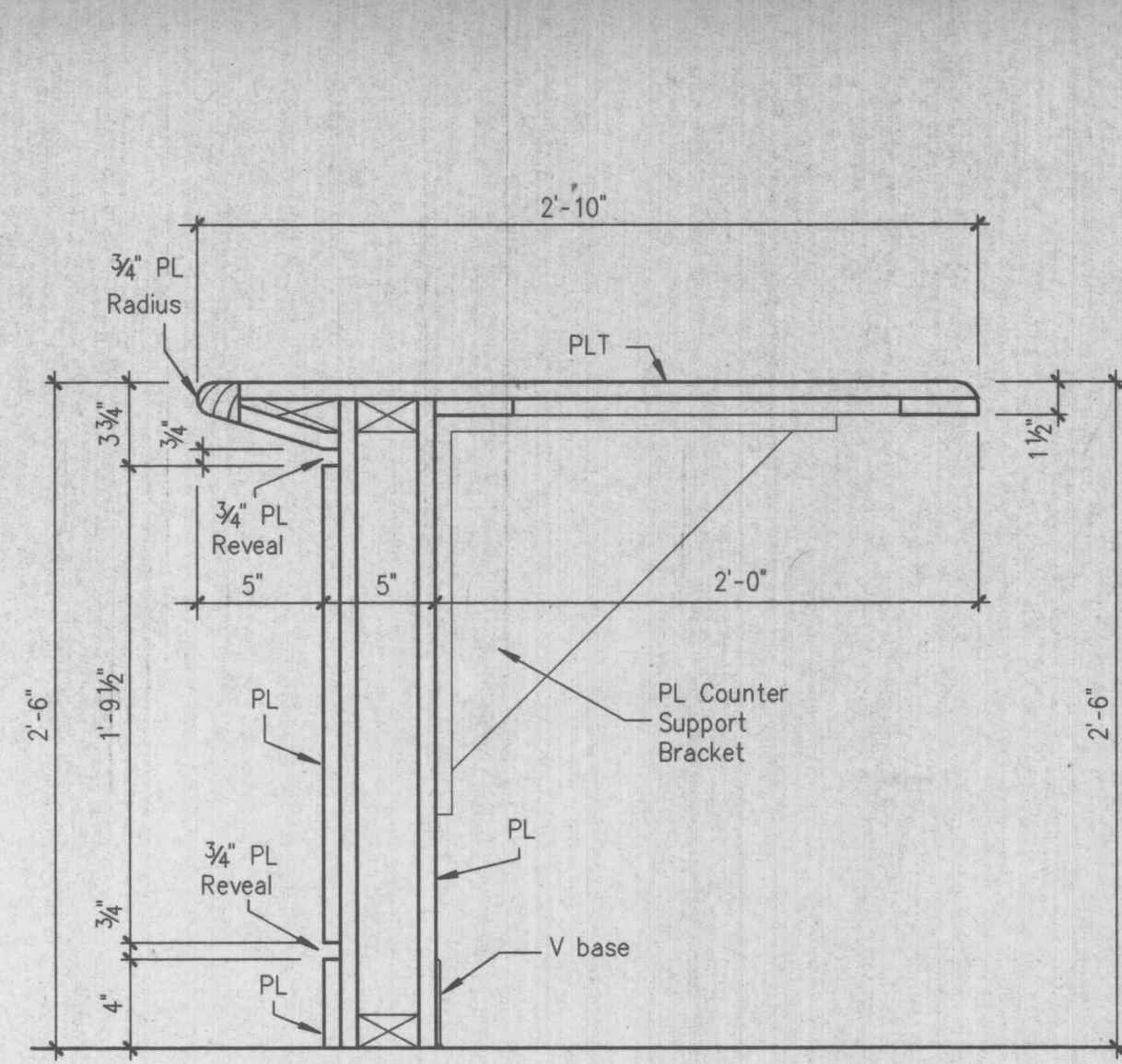

3 CASEWORK SECTION

A6.5 1 1/2" = 1'-0"

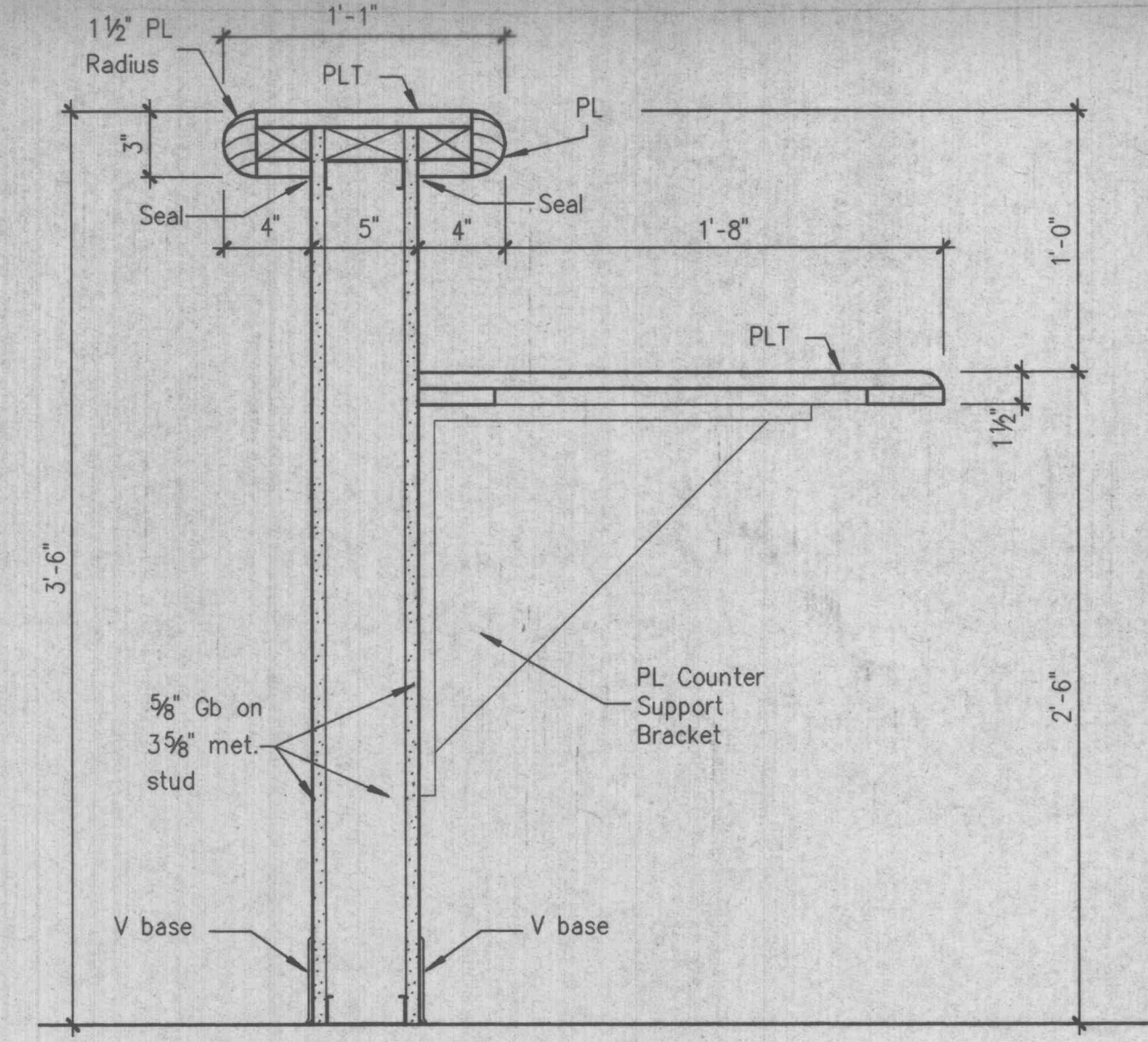

4 CASEWORK SECTION

A6.5 1 1/2" = 1'-0"

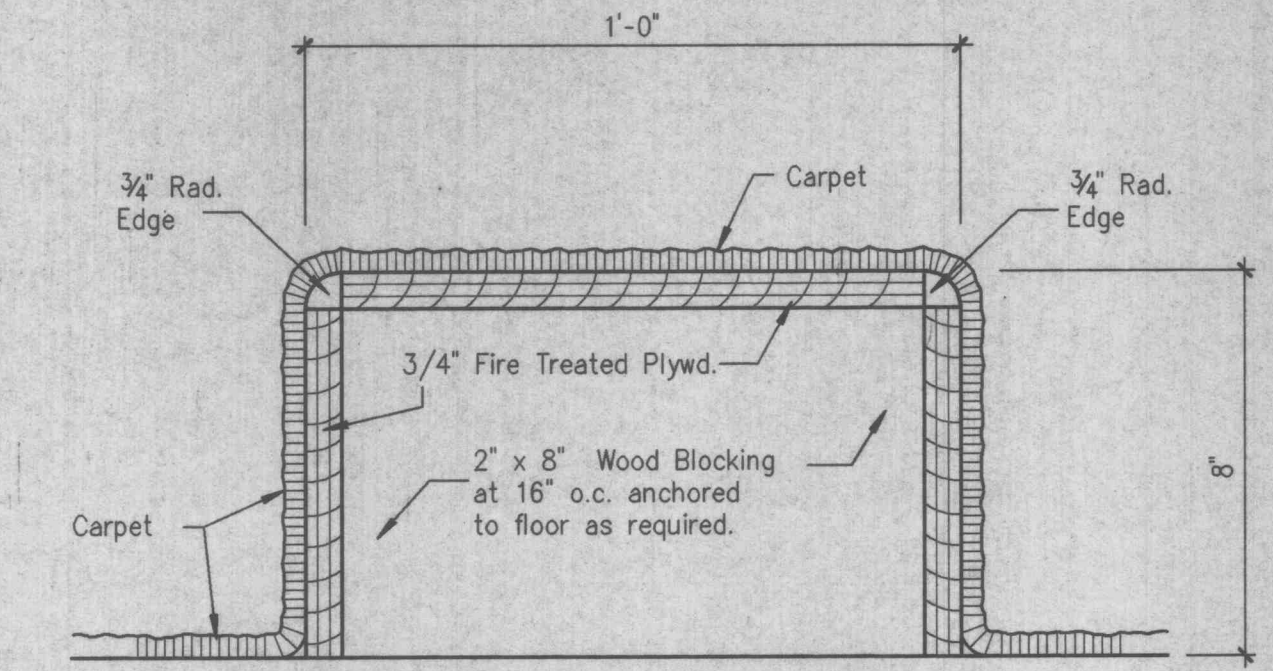

5 SECTION AT PLAY CURB

A6.5 1 1/2" = 1'-0"

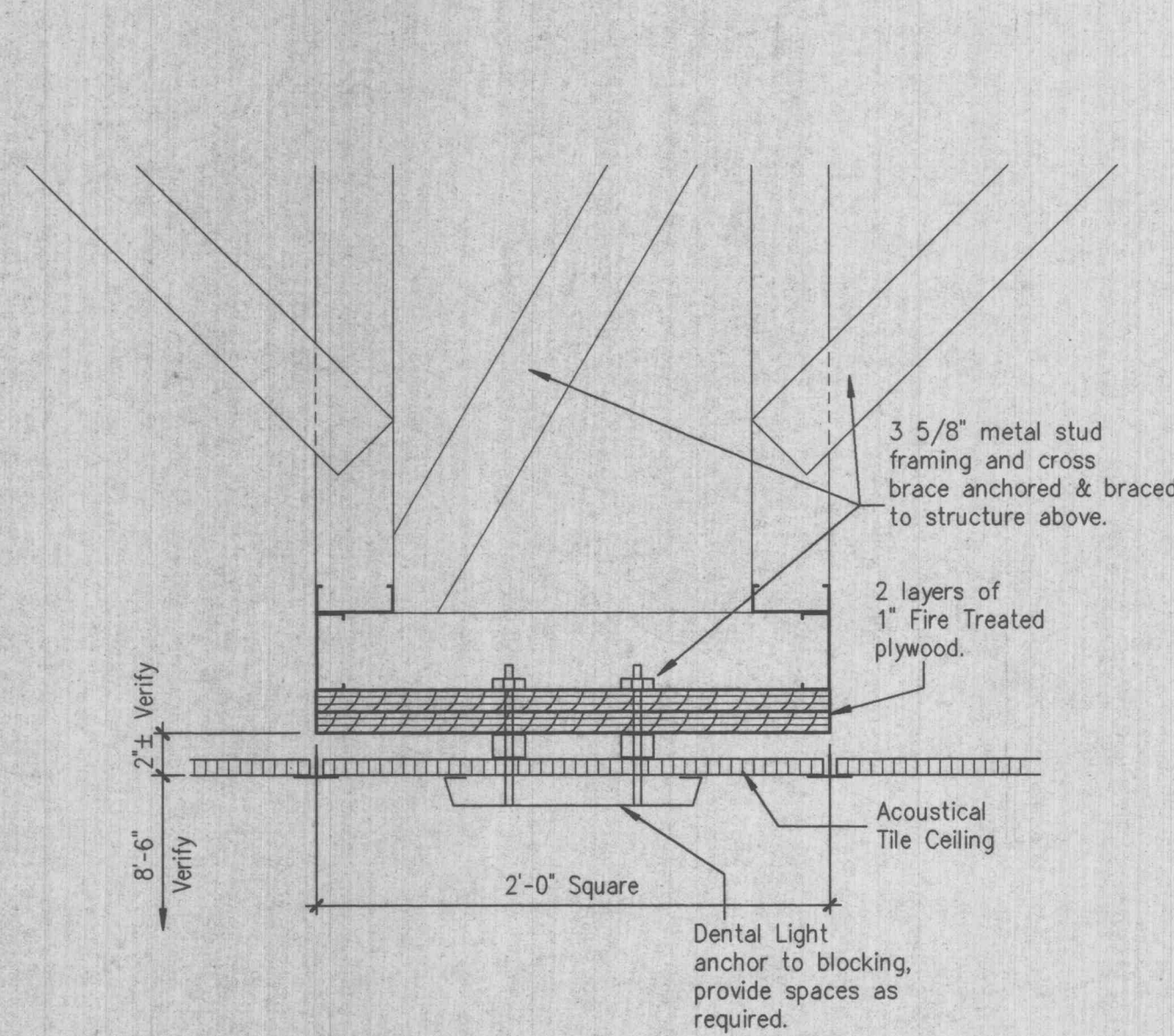

6 SUSPENSION DETAIL

A6.5 1 1/2" = 1'-0"

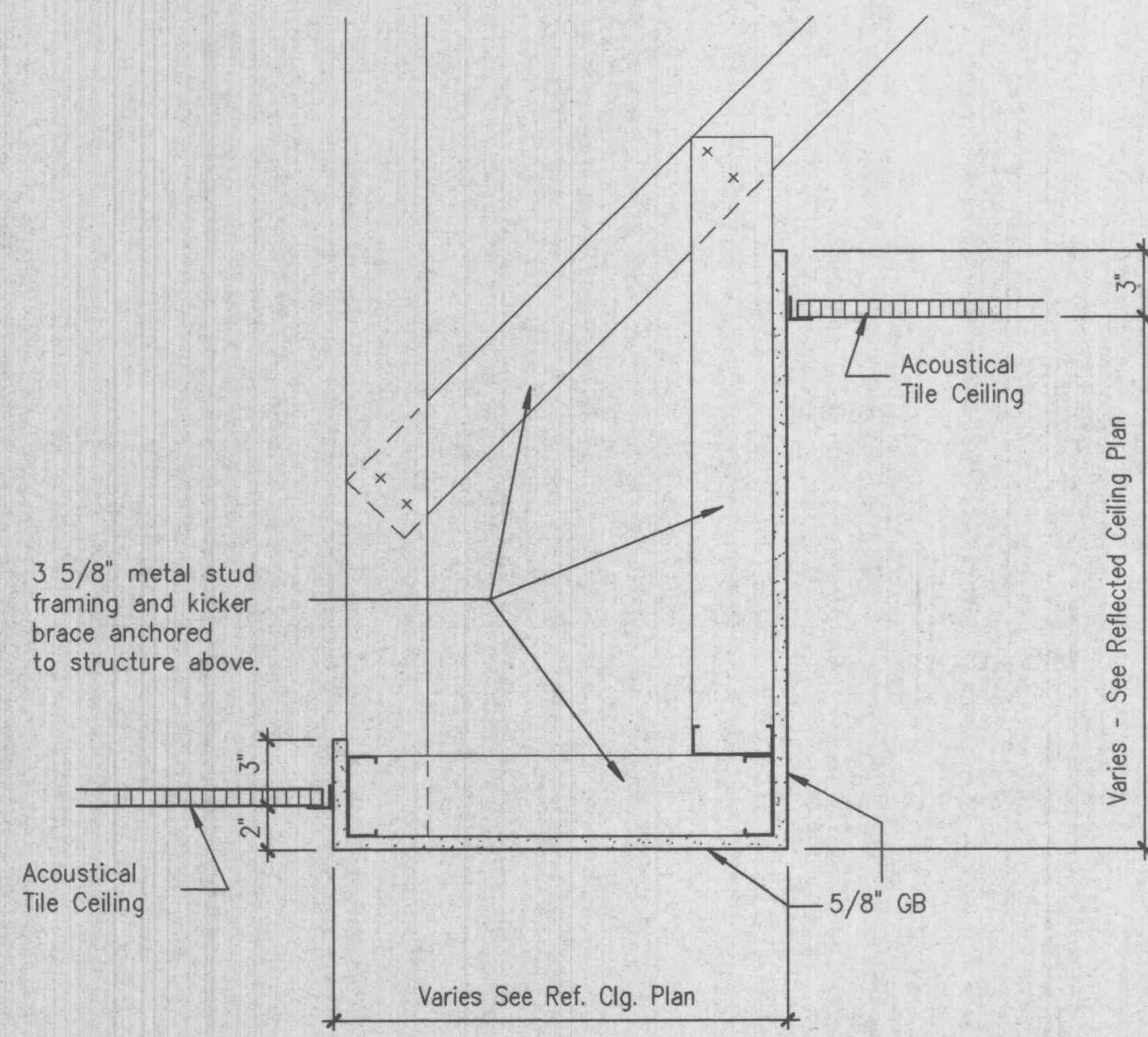

7 GYP. BD. SOFFIT DETAIL

A6.5 1 1/2" = 1'-0"

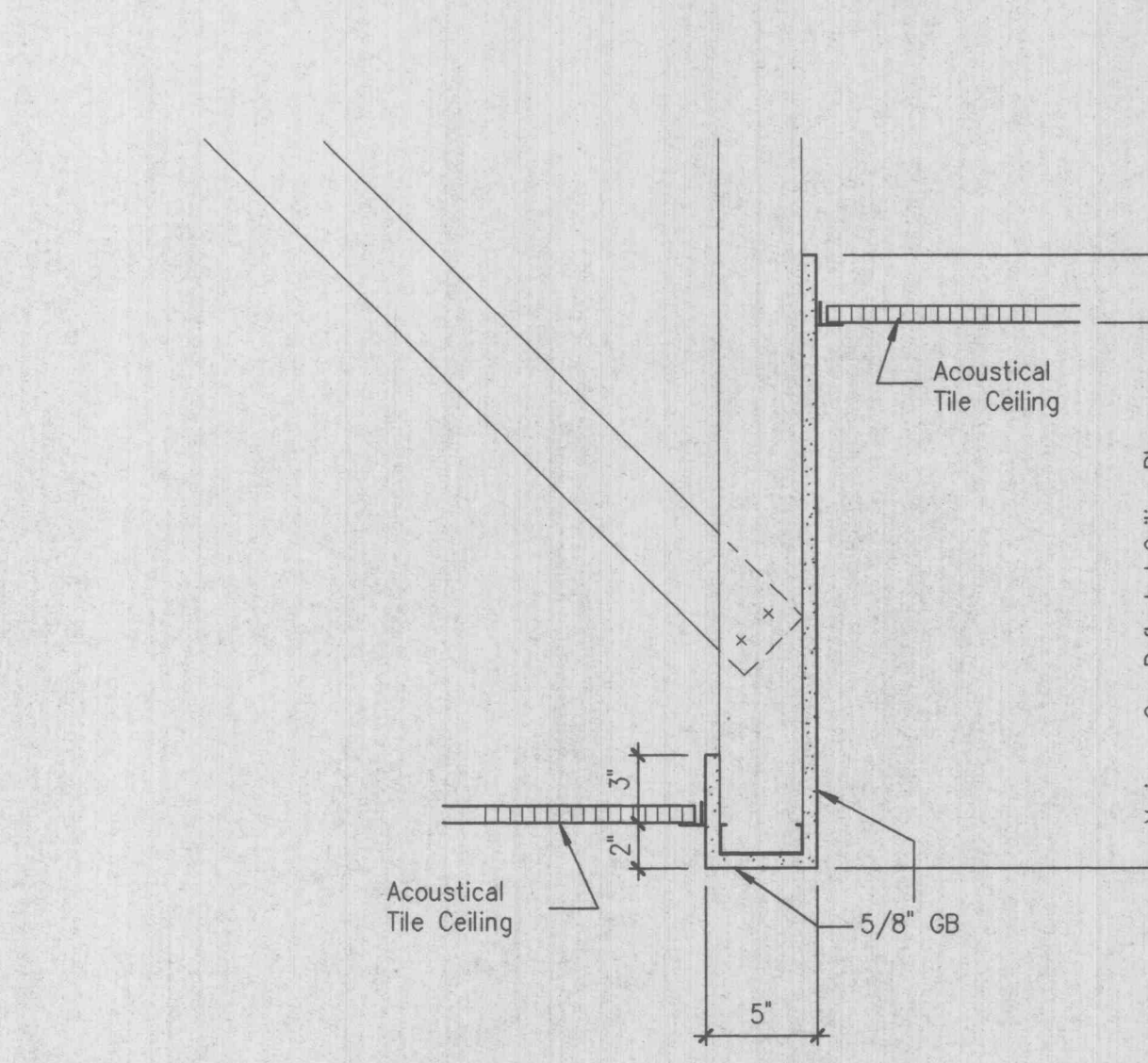

8 GYP. BD. SOFFIT DETAIL

A6.5 1 1/2" = 1'-0"

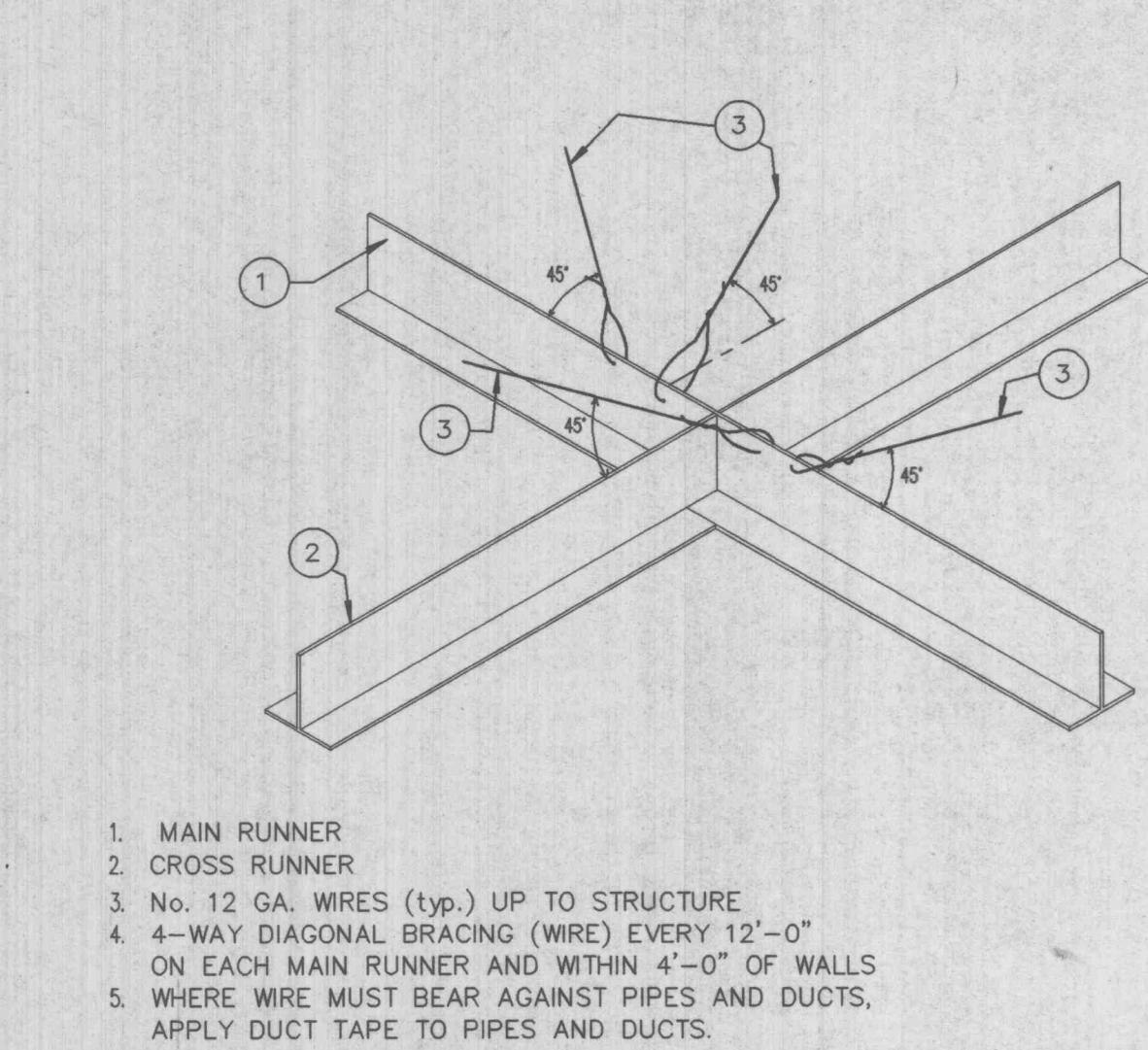

SUSPENDED ACOUSTICAL CEILINGS SEISMIC BRACING DETAIL

9 SEISMIC BRACING DETAIL

A6.5 NO SCALE

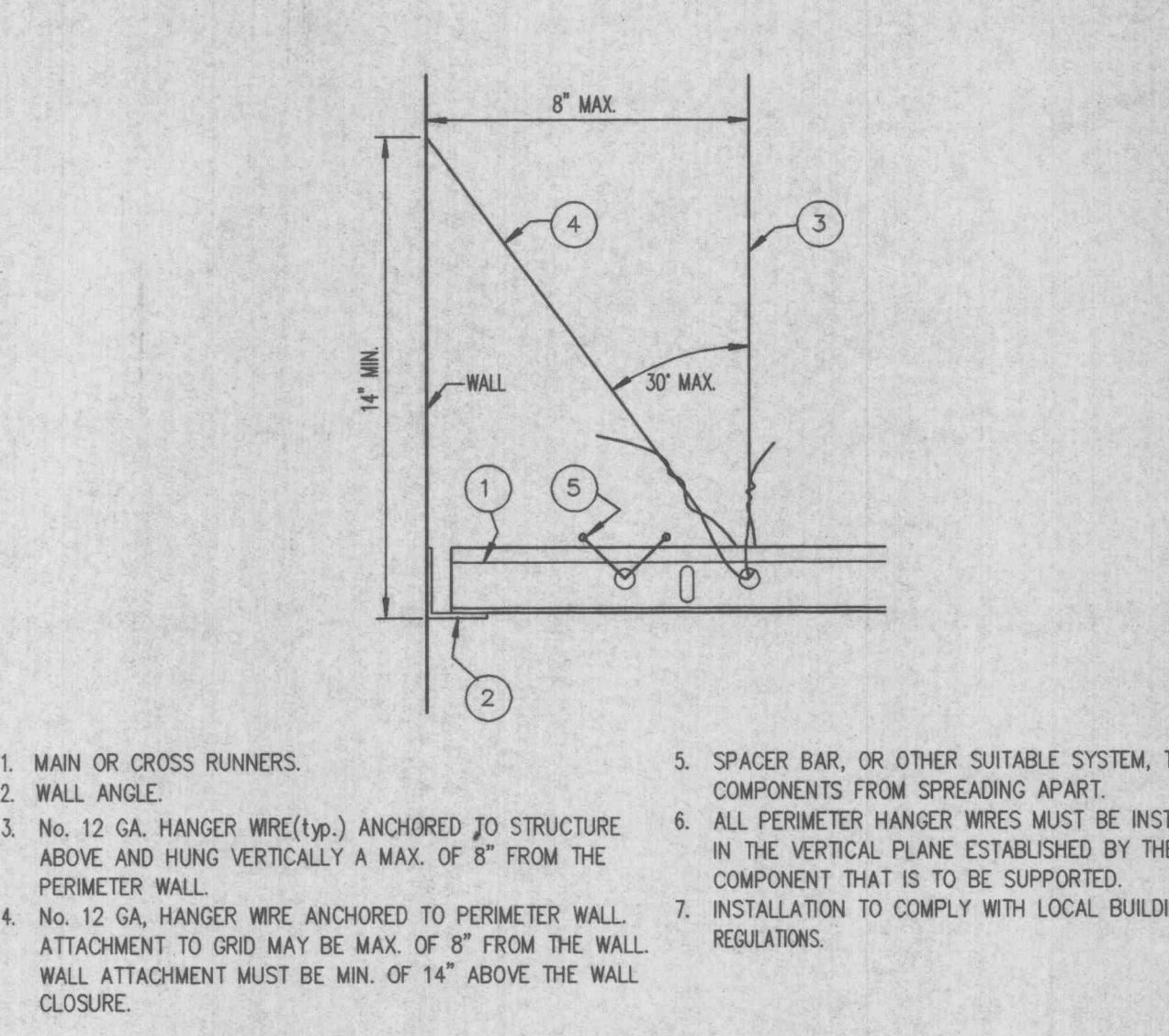

SUSPENDED ACOUST. CEILINGS PERIMETER SEISMIC BRACING DET.

10 PERIMETER SEISMIC BRACING DET.

A6.5 NO SCALE

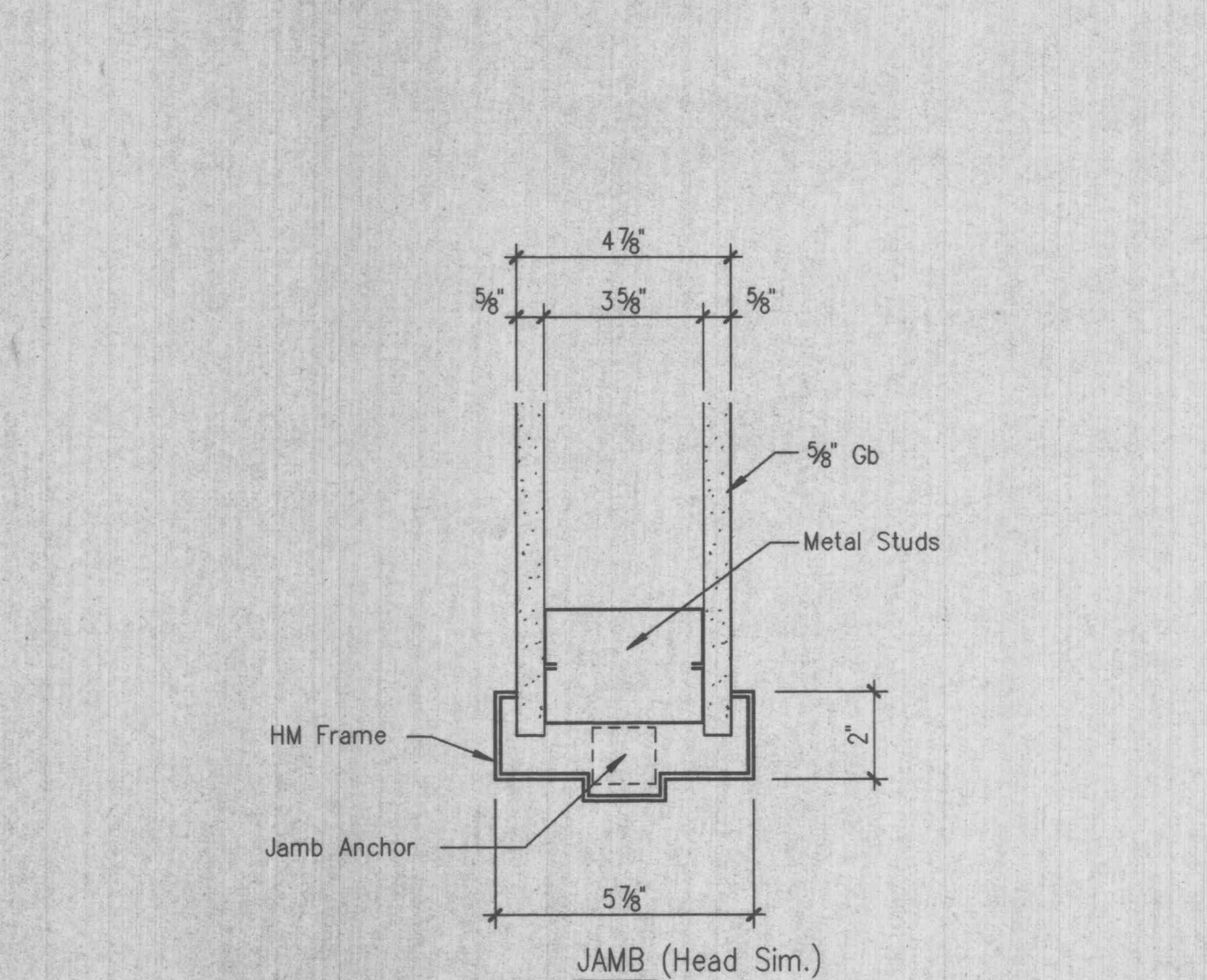

11 HM DOOR FRAME

A6.5 1 1/2" = 1'-0"

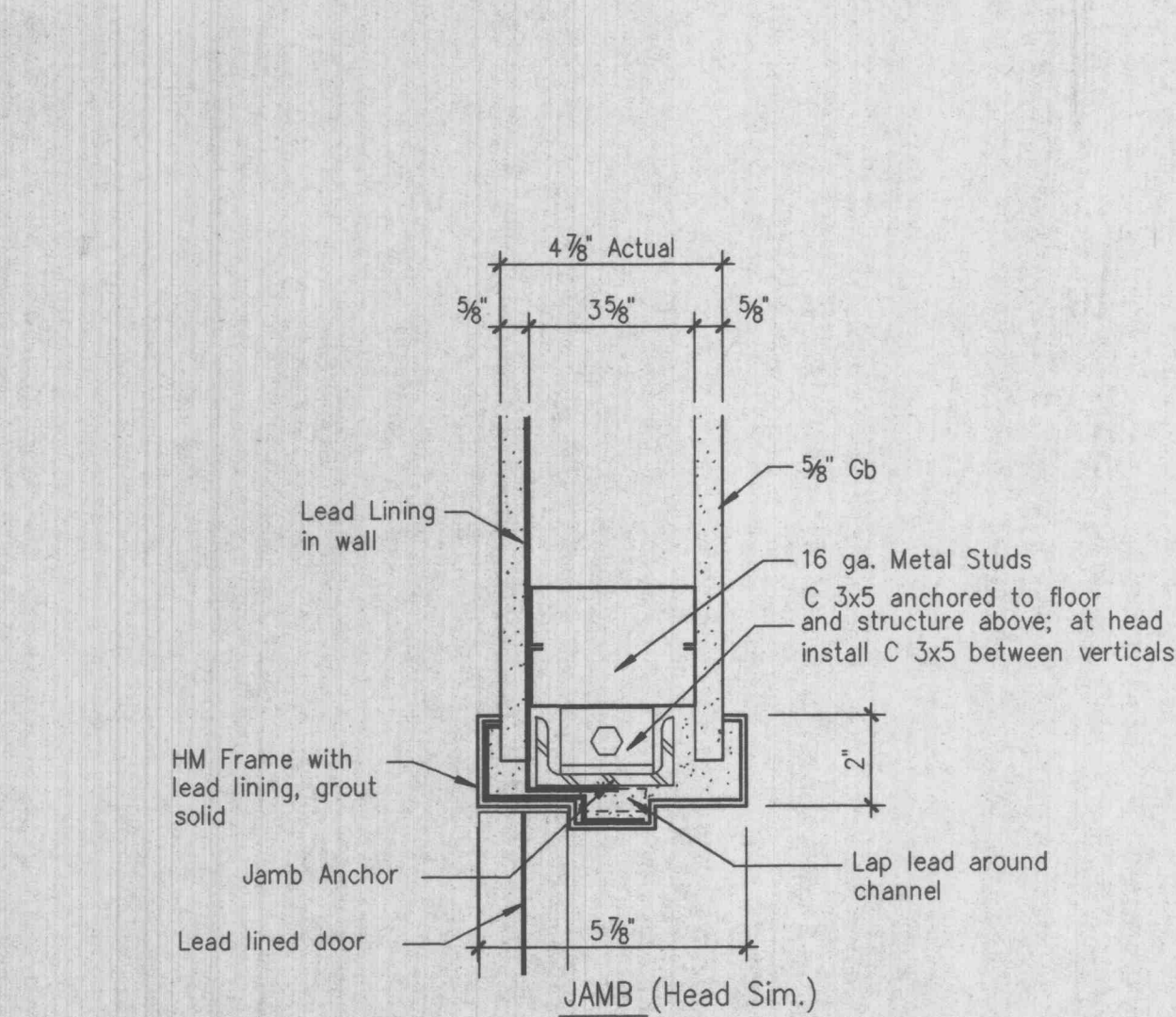

12 LEAD LINED DOOR FRAME

A6.5 1 1/2" = 1'-0"

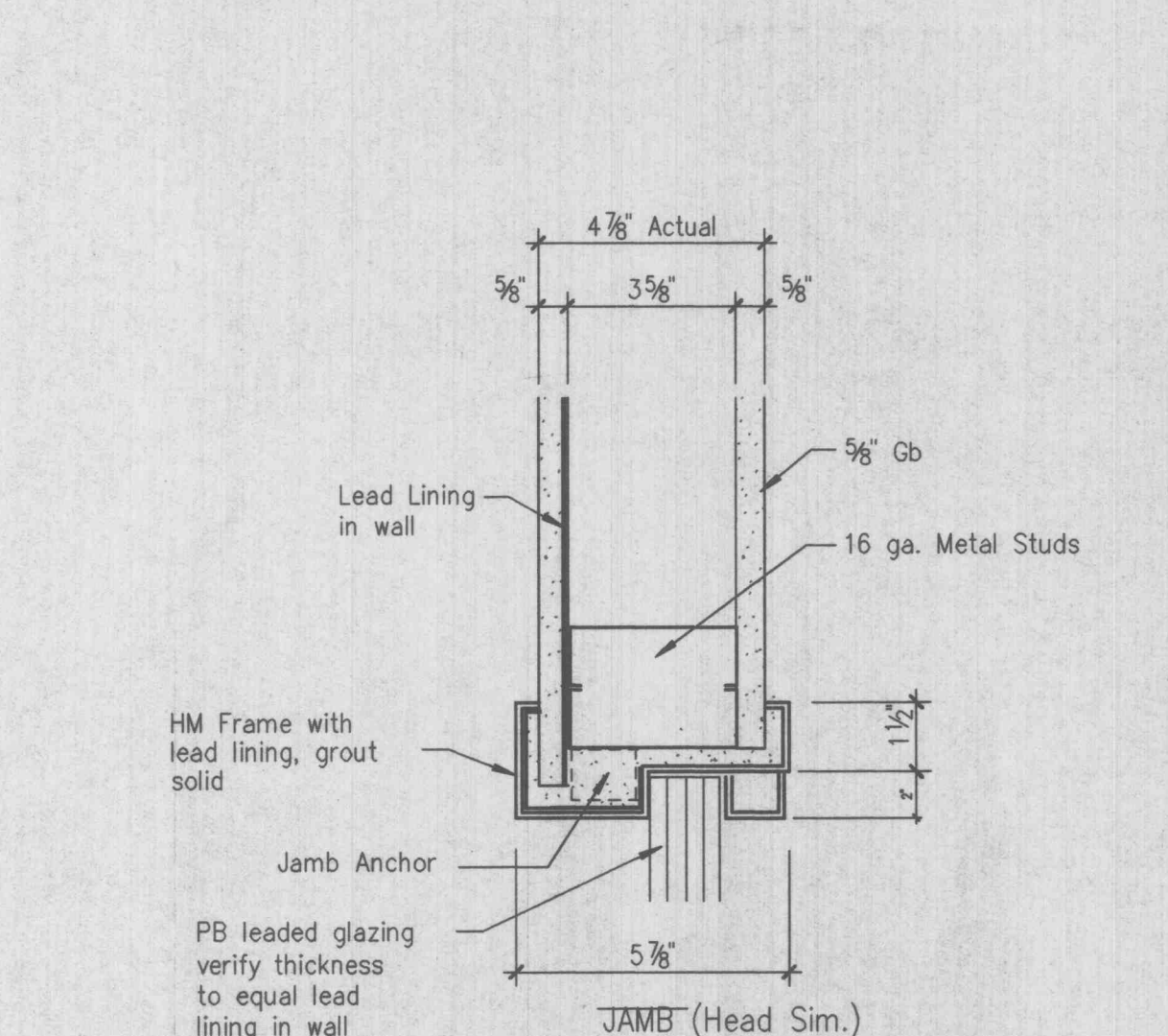

13 LEAD LINED BORROW LITE

A6.5 1 1/2" = 1'-0"

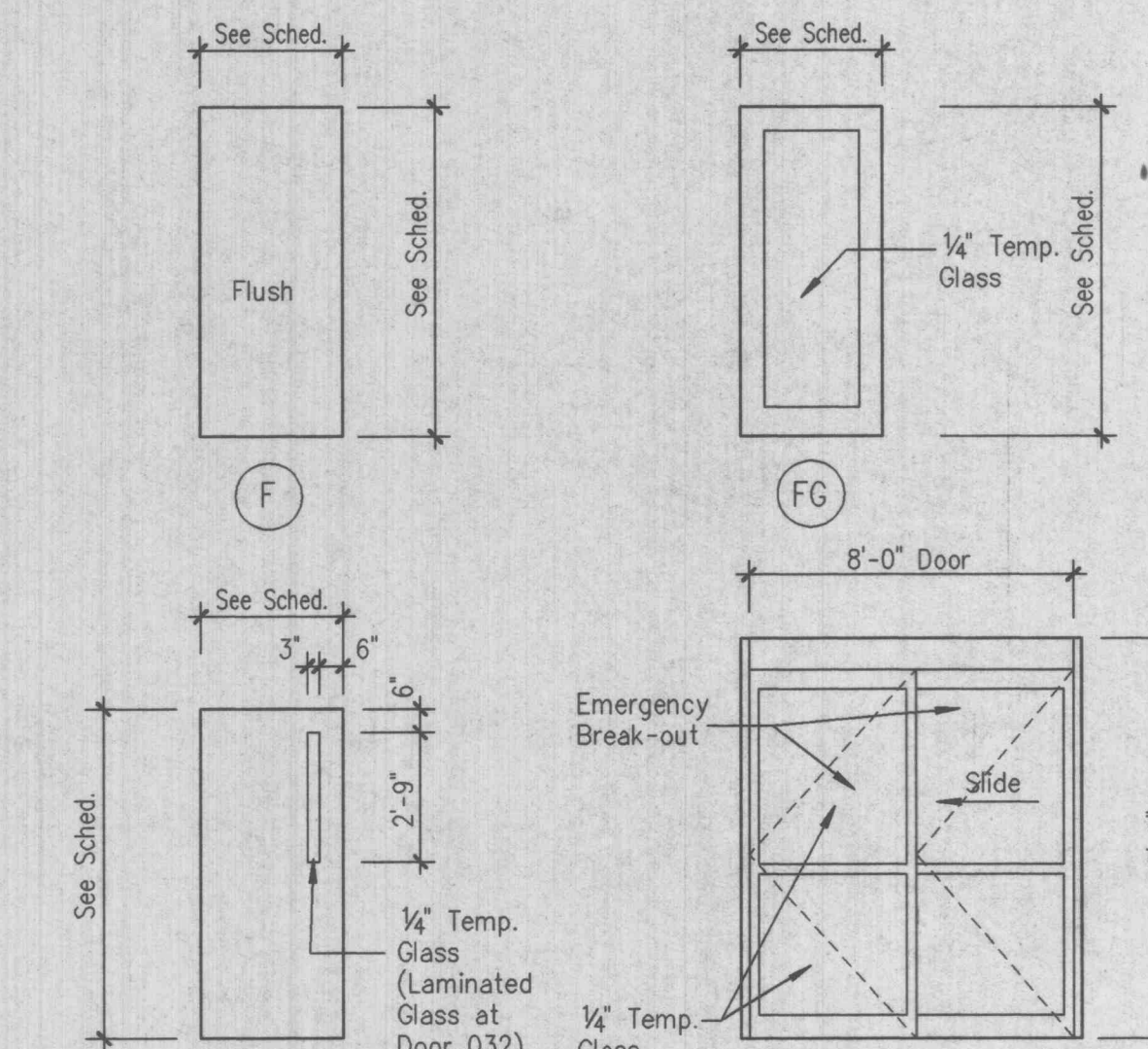

14 DOOR TYPES

A6.5 NTS

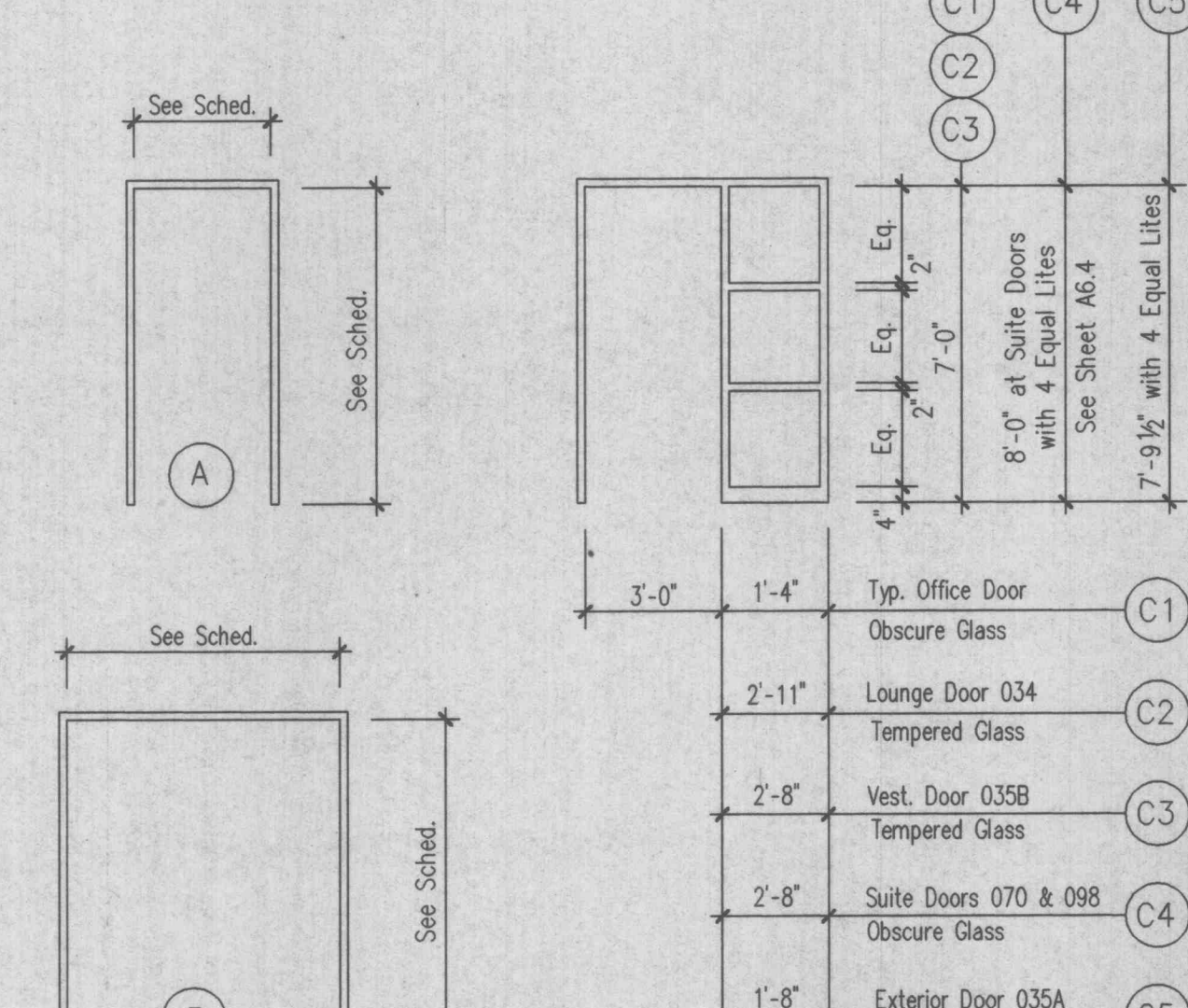

15 FRAME TYPES

A6.5 NTS

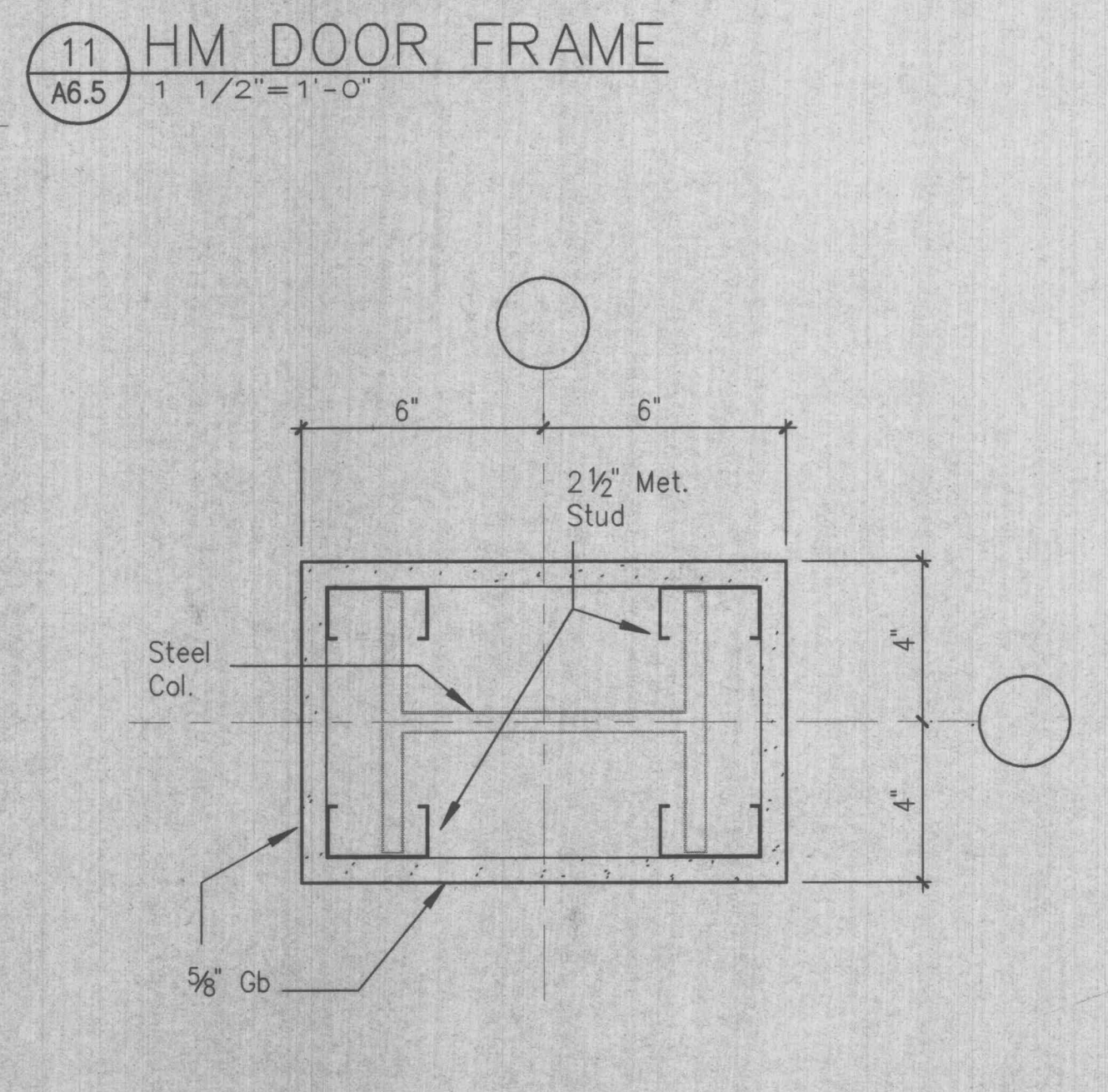

16 TYPICAL COLUMN DETAIL

A6.5 3" = 1'-0"

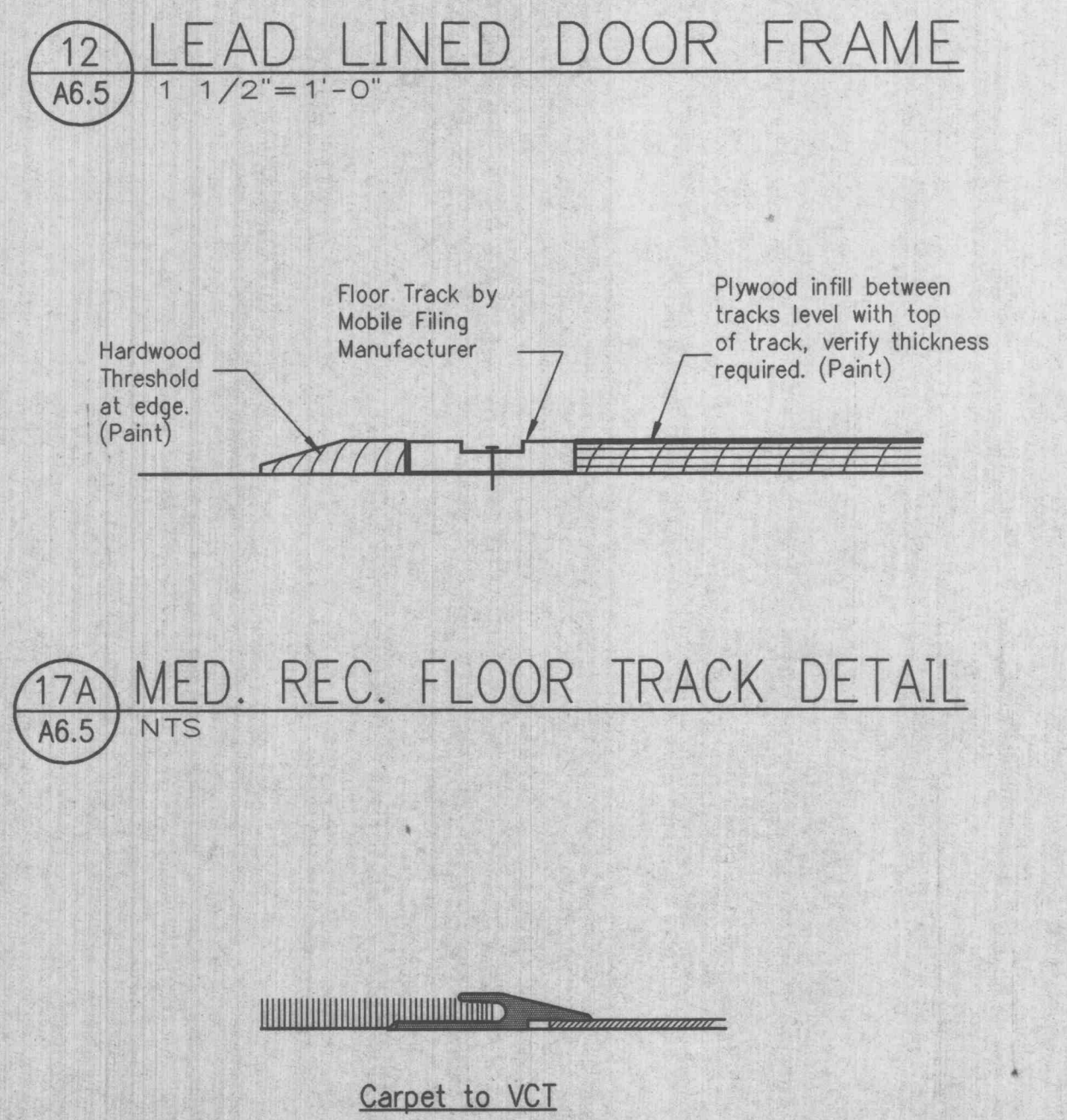

17A MED. REC. FLOOR TRACK DETAIL

A6.5 NTS

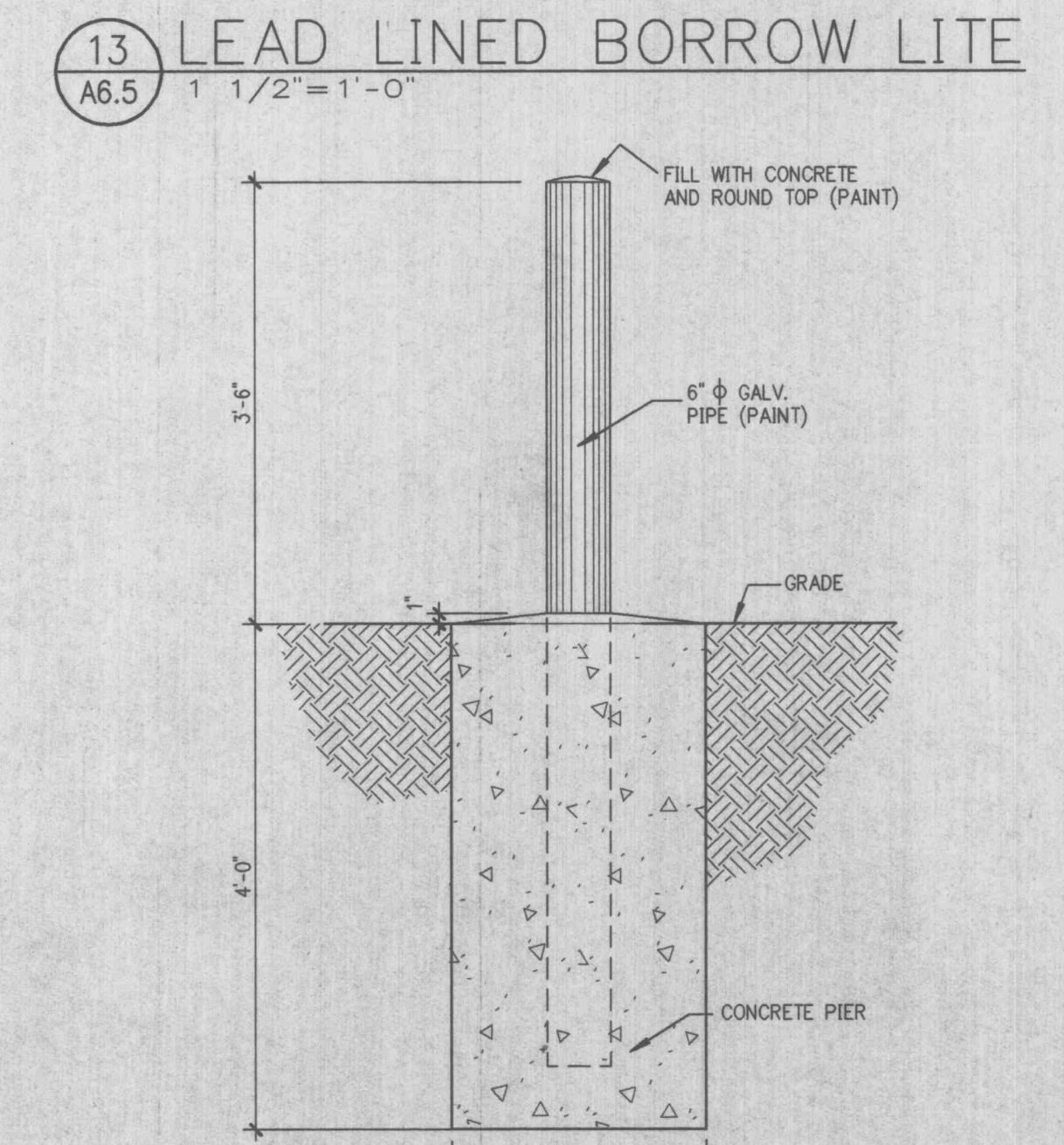

18 PIPE BOLLARD DETAIL

A6.5 3" = 1'-0"

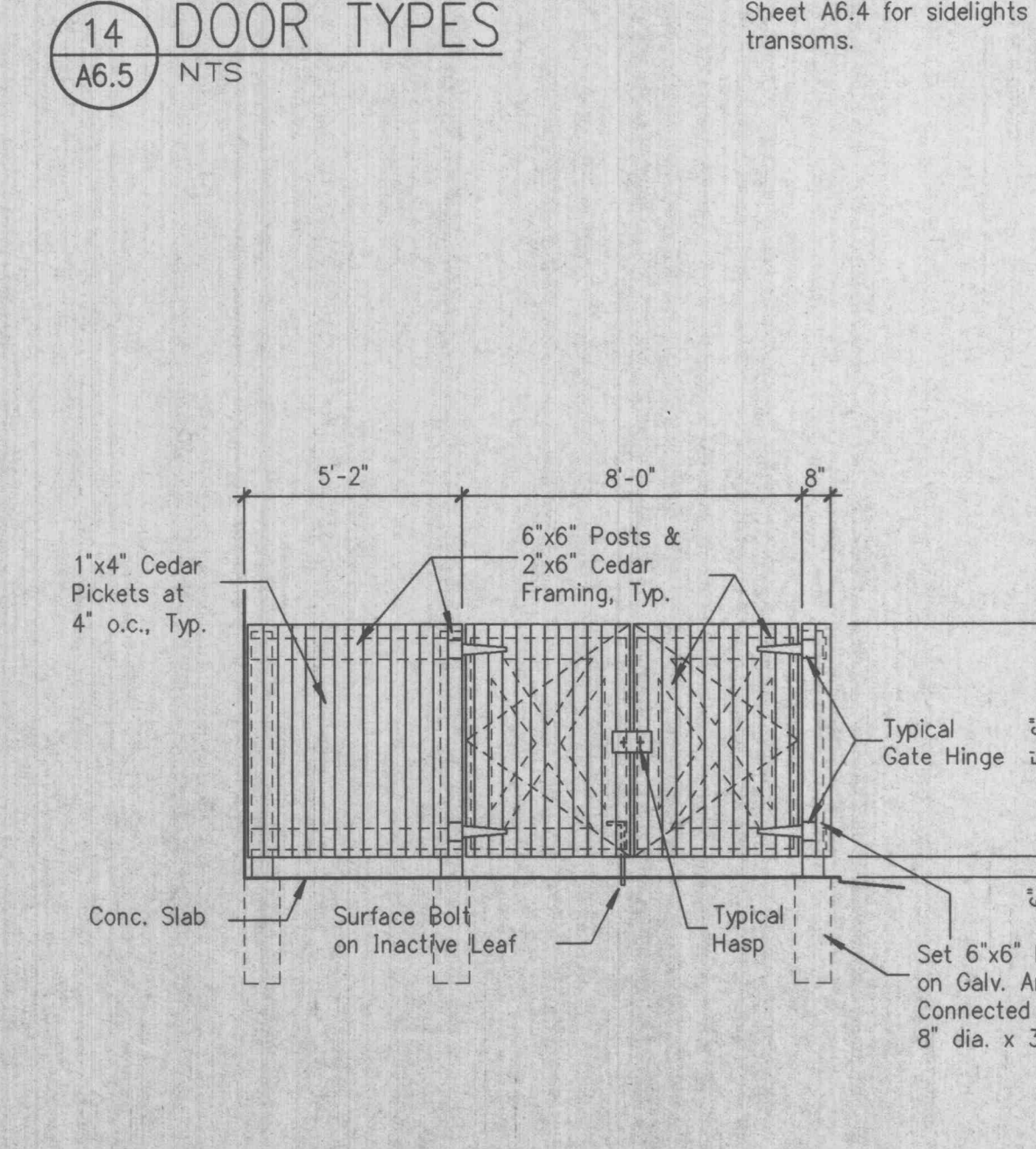

19 ELEVATION AT WOOD FENCE

A6.5 1/4" = 1'-0"

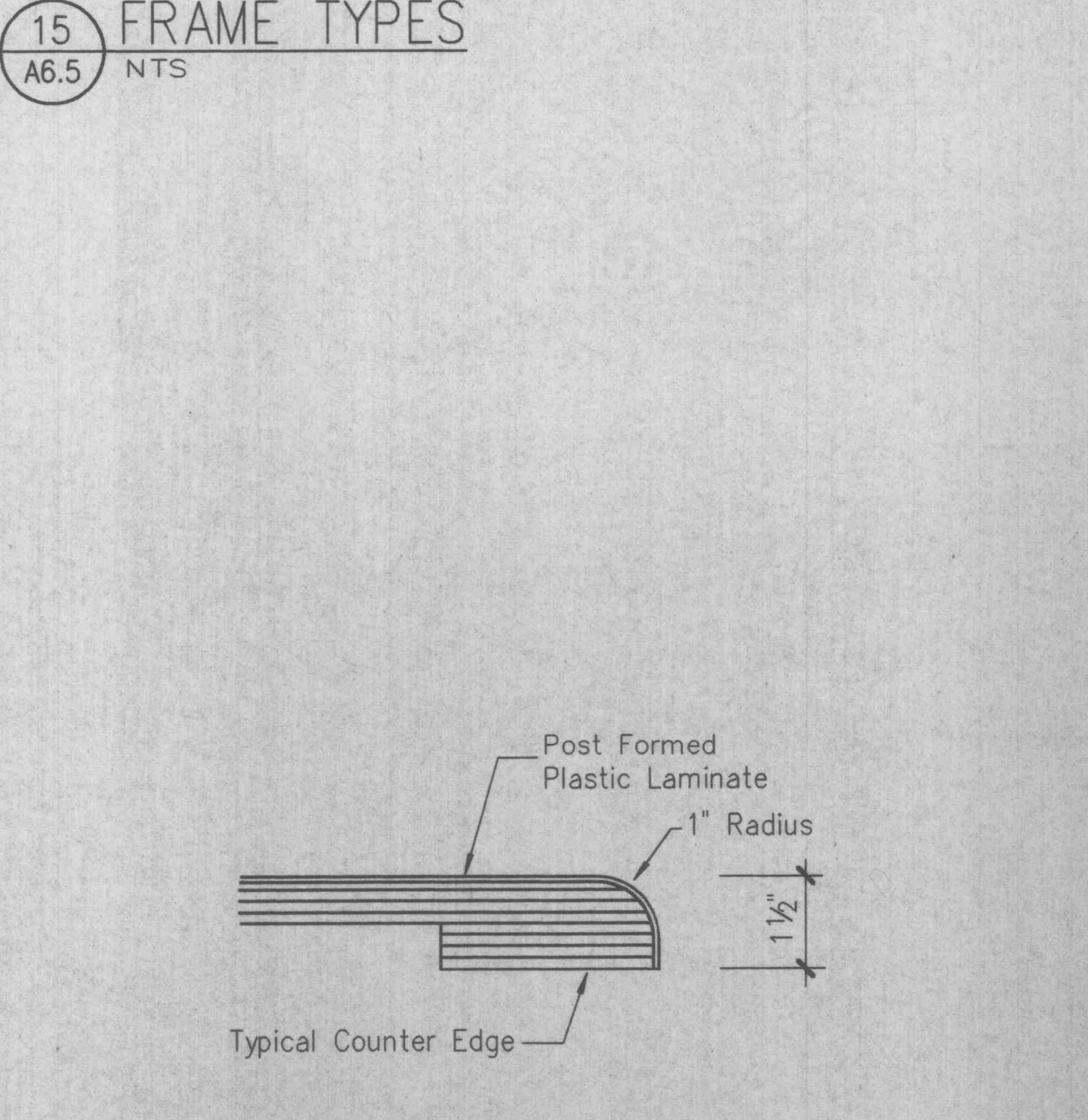

20 TYPICAL CABINET EDGE DETAIL

A6.5 6" = 1'-0"

I hereby certify that the portion of this technical submission described below was prepared by me or under my direct supervision and responsible charge. I am a duly registered architect under the laws of the state of Missouri.

Name: Steven E. Lichtenfeld

Signature: _____

Sheet: A6.5 of A6.5

Wischmeyer
THE WISCHMEYER ARCHITECTS

St. Louis, Missouri
Springfield, Missouri
Fayetteville, Arkansas

Architecture
Planning
Interiors
Consulting

1221 Locust Street
Saint Louis, Missouri 63103
314.231.4704 Telephone
314.231.4331 Fax

Client:

BJC Health System
9890 Clayton Road
Suite 100
St. Louis, Mo. 63124
1-314-953-1980

BJC HEALTH SYSTEM

Project:

BJC - O'Fallon Family Health Center

2360 Highway K
O'Fallon, Missouri
63366

Revisions

Prj # 97049
Date: 11/14/97
Sheet Contents

MISC. DETAILS

Sheet No.

A6.5

The Wischmeyer Architects, Inc. 1997(c)