

# STORM SEWER

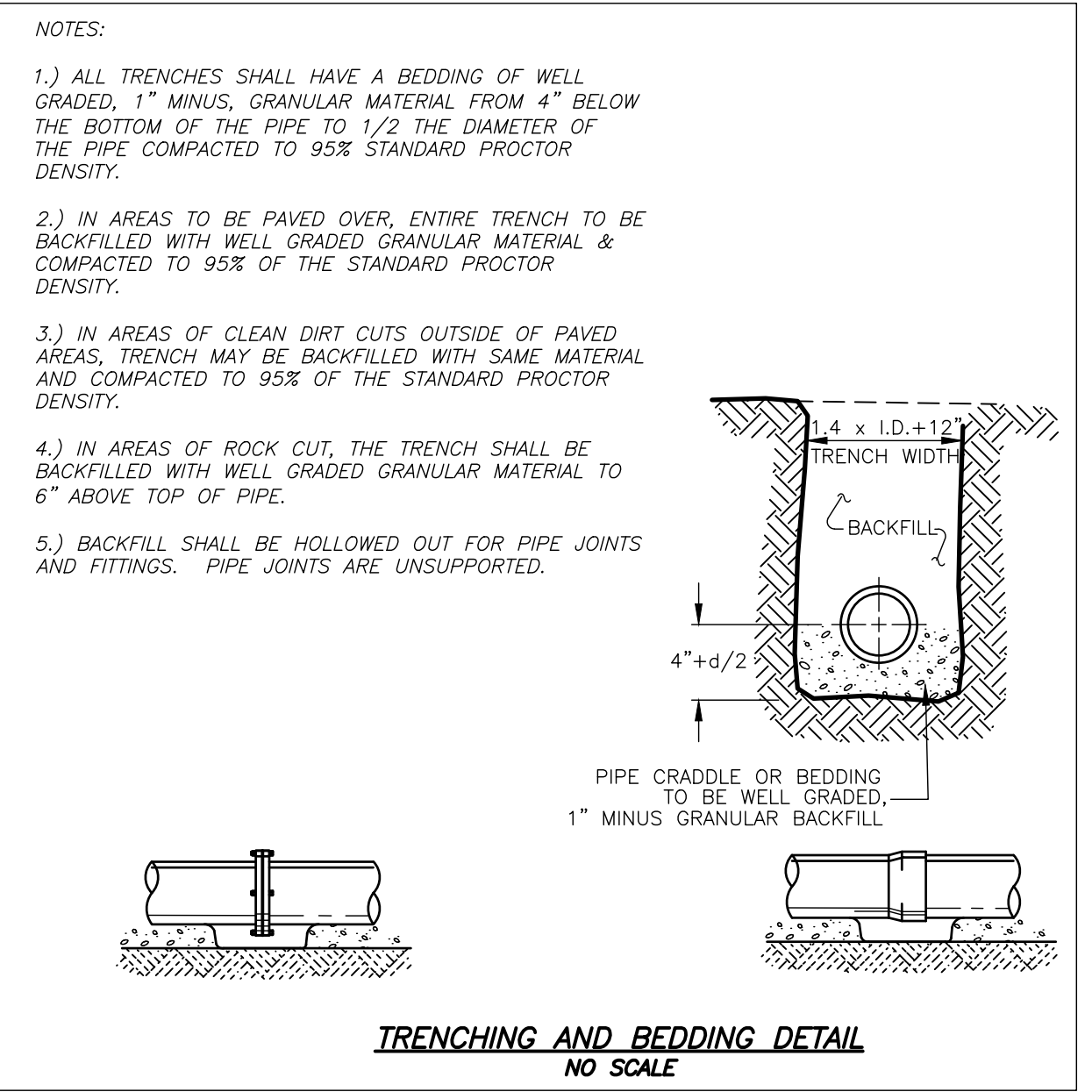
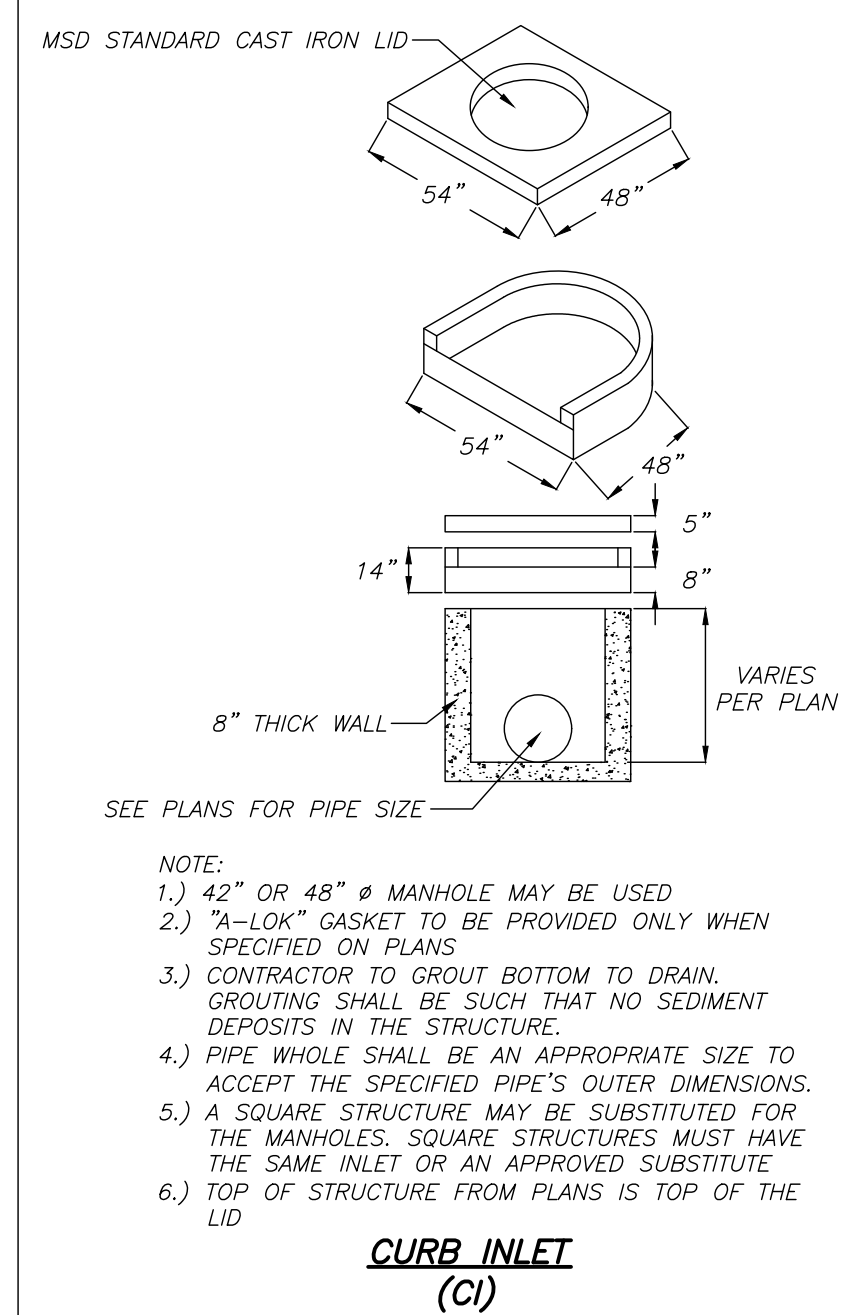

\* The City of O'Fallon must be provided with a symbol/medallion for review and approval prior to installation. Contact the City if any information is needed.

| Size         | Style                         | Adhesive | Message (Part #)              |
|--------------|-------------------------------|----------|-------------------------------|
| 3 7/8" TO 4" | Crystal Cap or Standard Style | Epoxy    | No Dumping Drains to Waterway |

City will also allow the precast inlet stone with a similar message as an approved alternate to the marker.

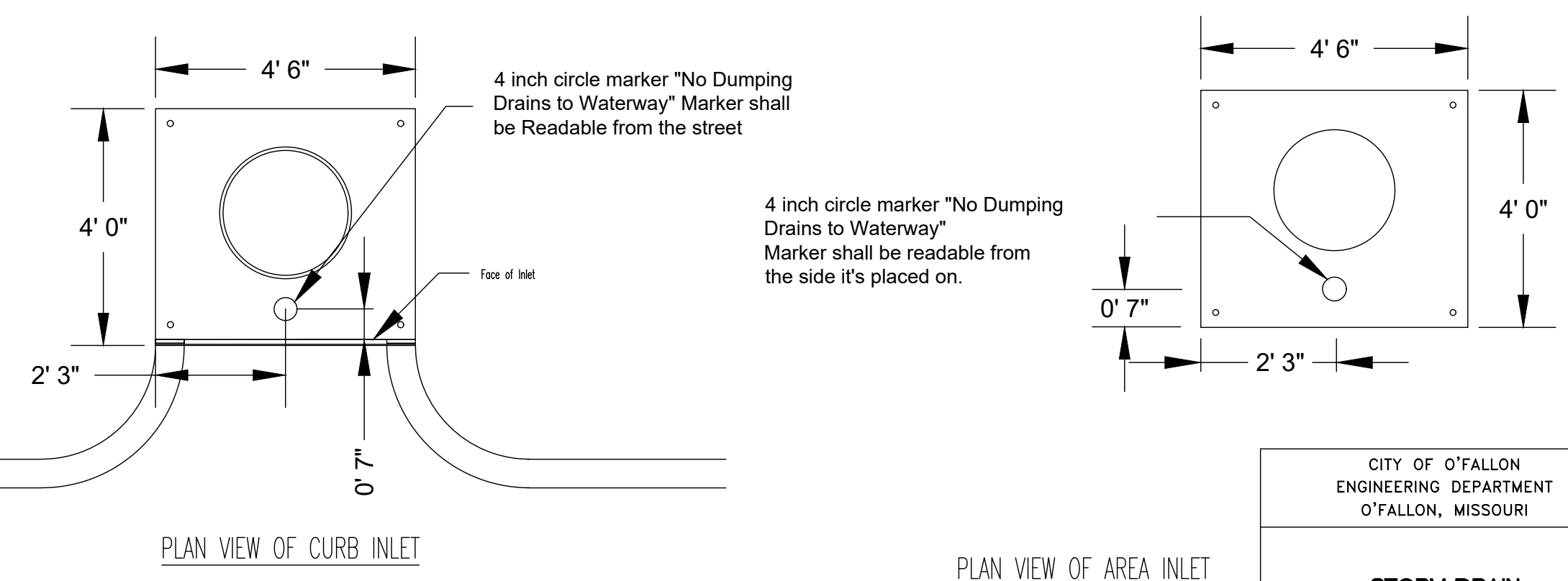

|  |                               |
|--|-------------------------------|
| CITY OF O'FALLON<br>ENGINEERING DEPARTMENT<br>O'FALLON, MISSOURI | CAD DWG. REF: 4580-2727.DWG-1 |
| <b>STORM DRAIN<br/>MARKER LOCATION</b>                           | COVER<br>4580                 |

**Public inlets only.**  
Also available at East Jordan foundry

MATERIAL: CAST GRAY IRON ASTM A-48, CLASS 35B  
FINISH: NO PAINT UNLESS SPECIFIED ON PURCHASE ORDER  
WEIGHT: 85 LBS.

|                       |                  |  |
|-----------------------|------------------|--|
| DR. KRH               | SCALE: 1/8"=1'   | TITLE: 4580 COVER  |
| APP.                  | DATE: 11/21/2013 | NEENAH FOUNDRY   |
| www.neenahfoundry.com |                  | NEENAH, WISCONSIN 54956<br>PHONE: 800-528-5079<br>LINCOLN, NEBRASKA 68529<br>PHONE: 800-224-7466 |

NEENAH FOUNDRY  
512 EAST MAIN STREET  
UNION, MO 63084 (636) 583-8400  
WSETEAM.COM

NR-4580-2727

**Blue Sky Health and Wellness**

**WUNDERLICH SURVEYING & ENGINEERING INC.**  
512 EAST MAIN STREET  
UNION, MO 63084 (636) 583-8400  
WSETEAM.COM

WUNDERLICH SURVEYING & ENGINEERING, INC.  
MISSOURI STATE CERTIFICATE OF AUTHORITY  
LAND SURVEYING: 002253

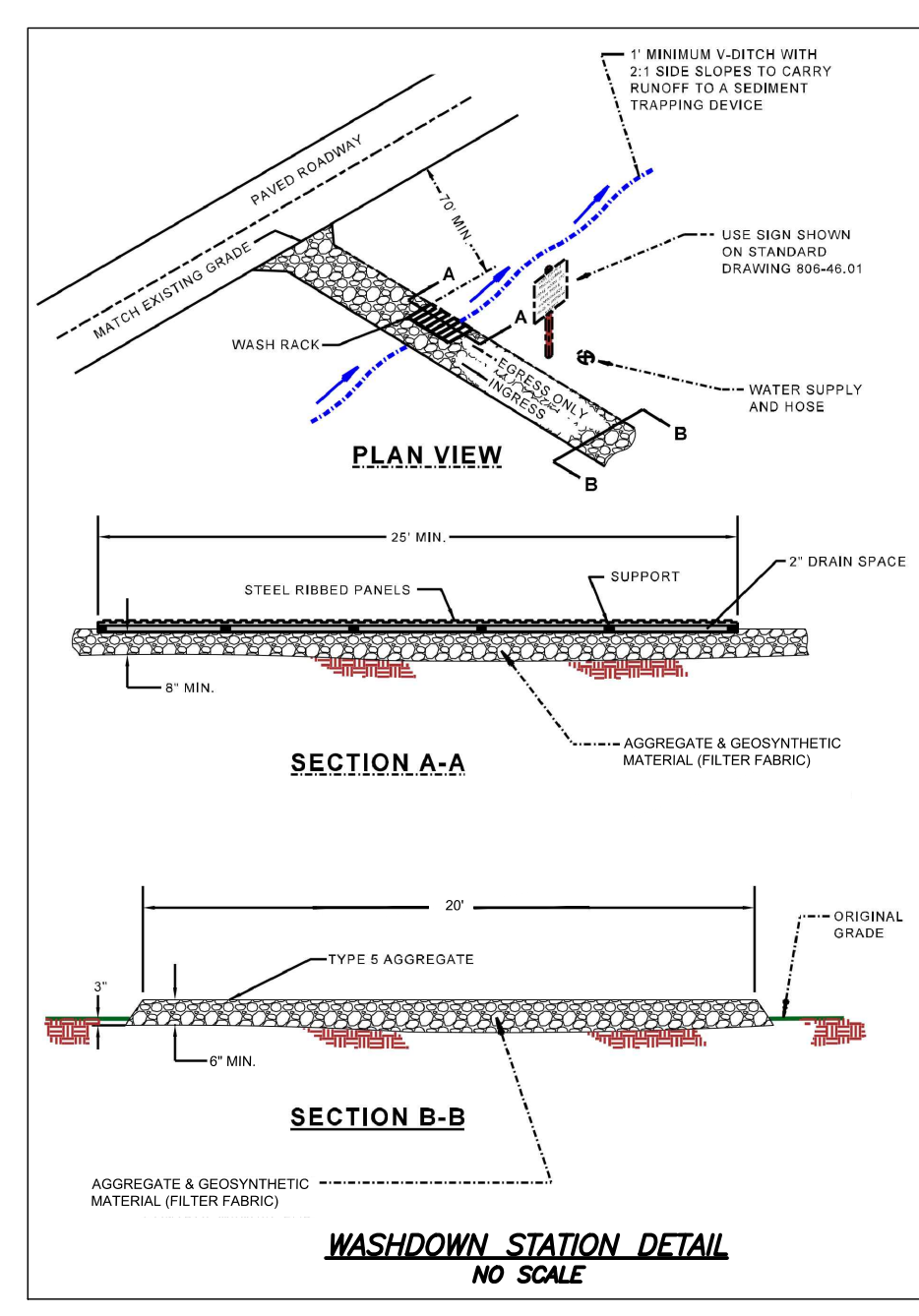
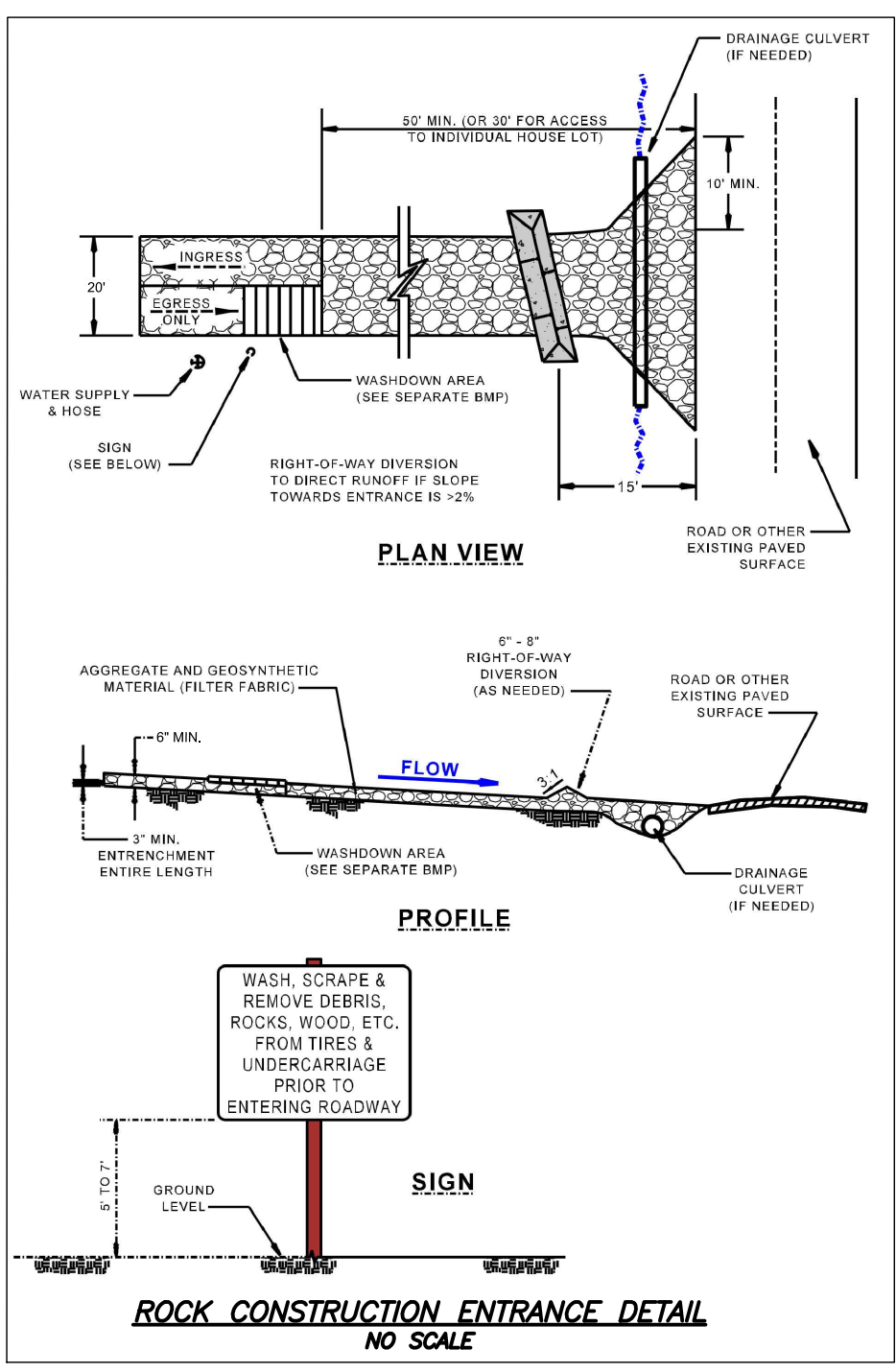

\* All other Storm or Sanitary Sewer Details will be by M.S.D. Standards and Specifications.  
\*\* All inlets shall have 5/8" trash bar centered with the opening(s).

Ronald L. DeClue, P.E. - 2012000745  
P.E. for Wunderlich Surveying & Engineering Inc.

THIS SEAL IS FOR DESIGN ONLY AND NOT CONSTRUCTION INSPECTION OR STAKING OUT OF IMPROVEMENTS

# WATER

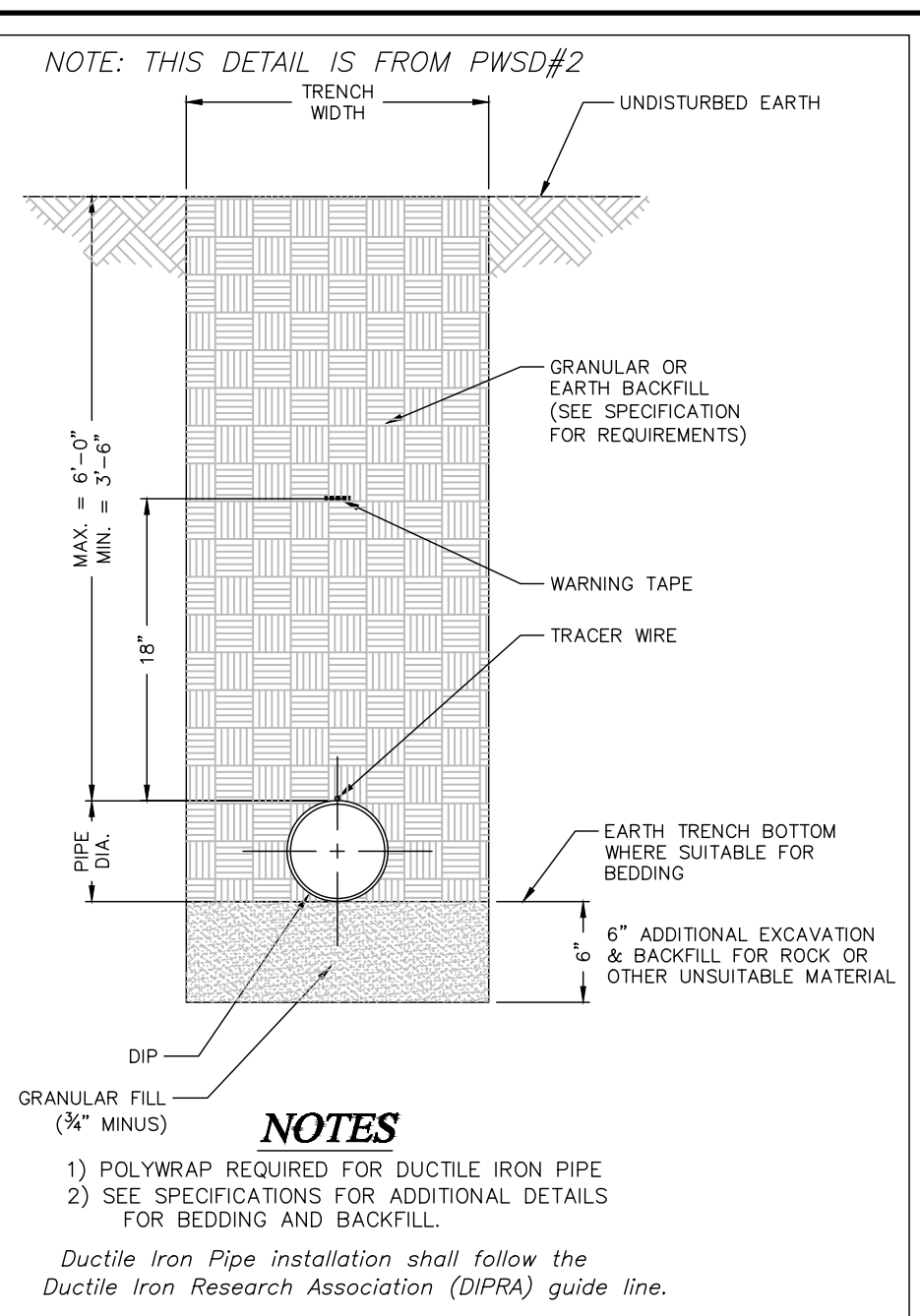
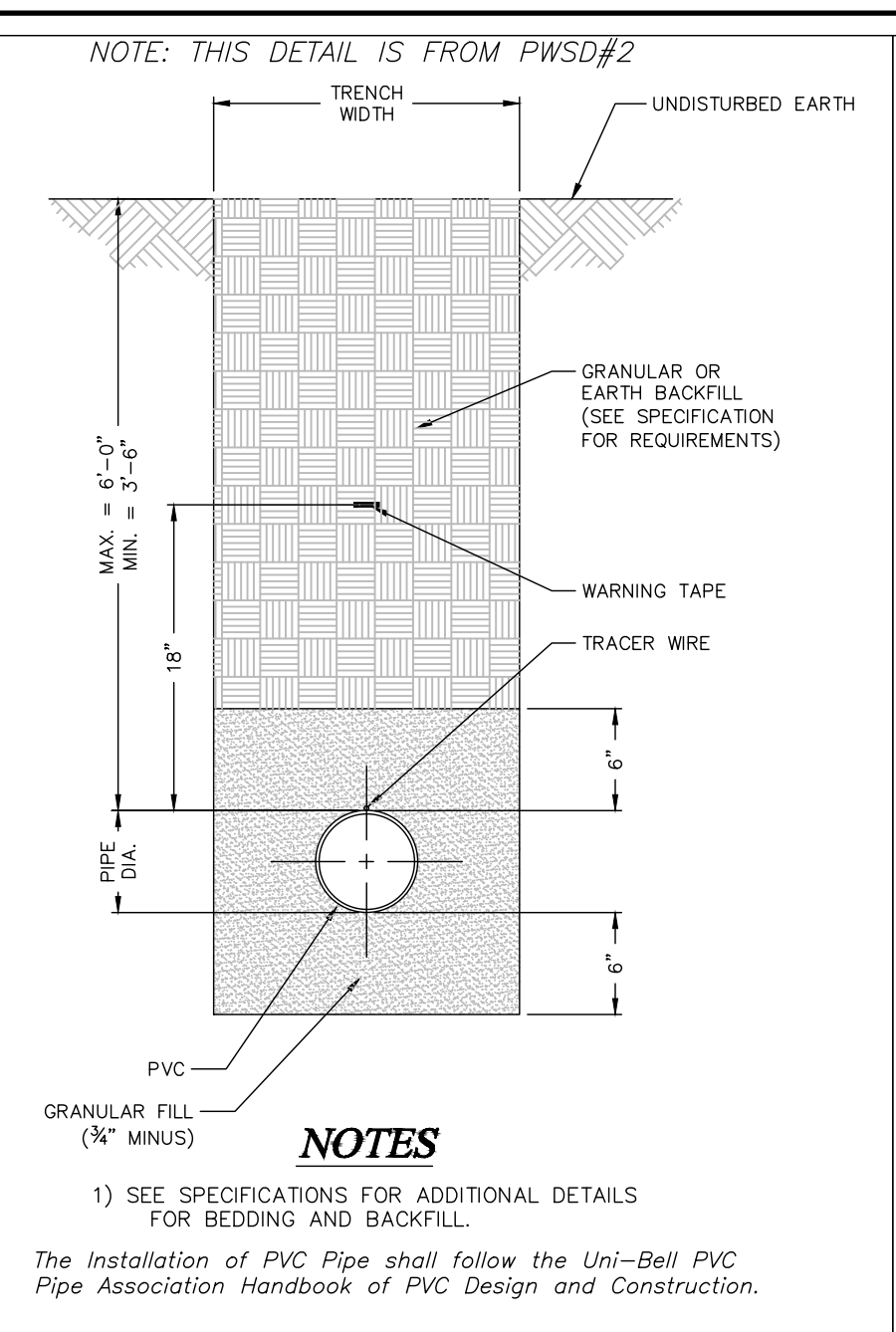
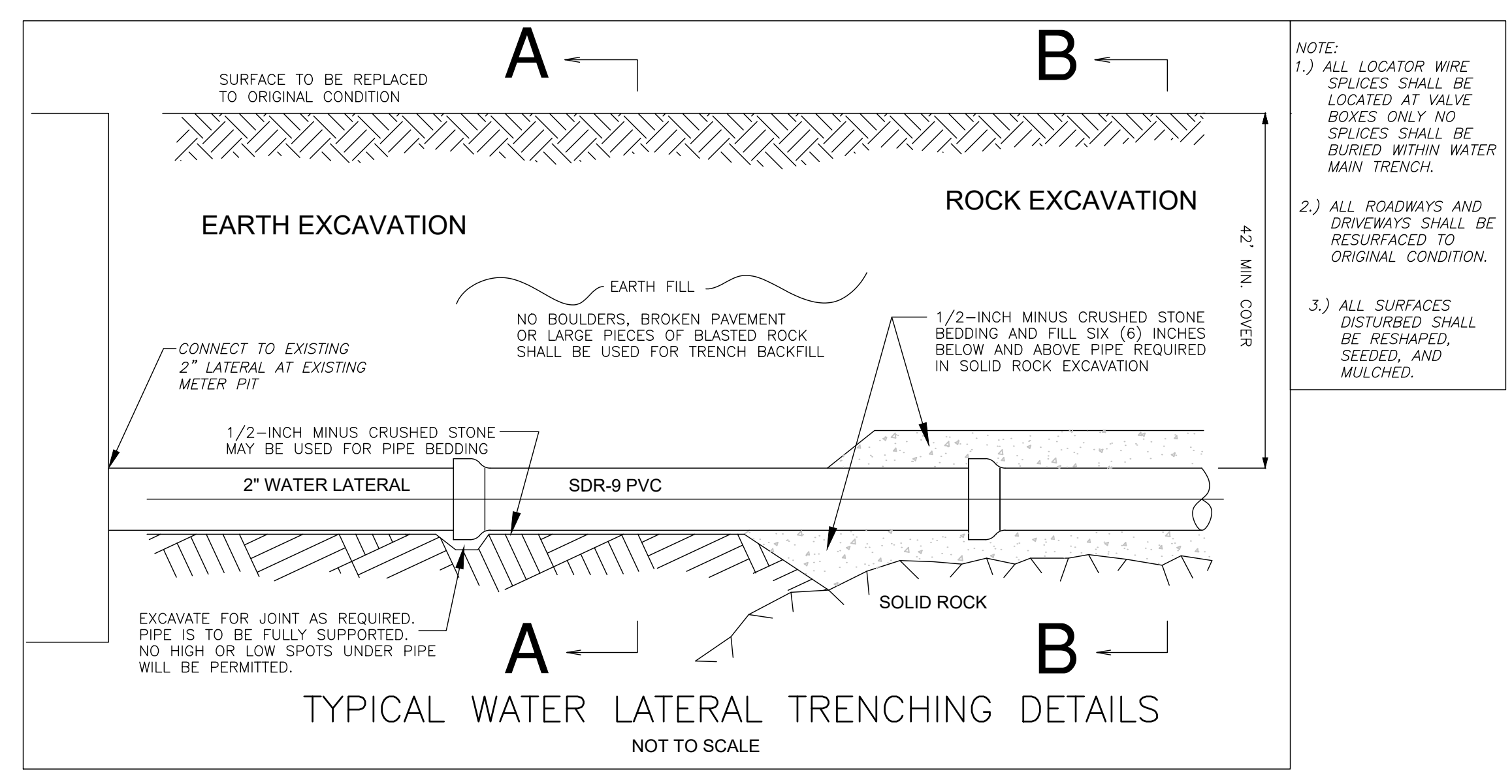

# SANITARY SEWER

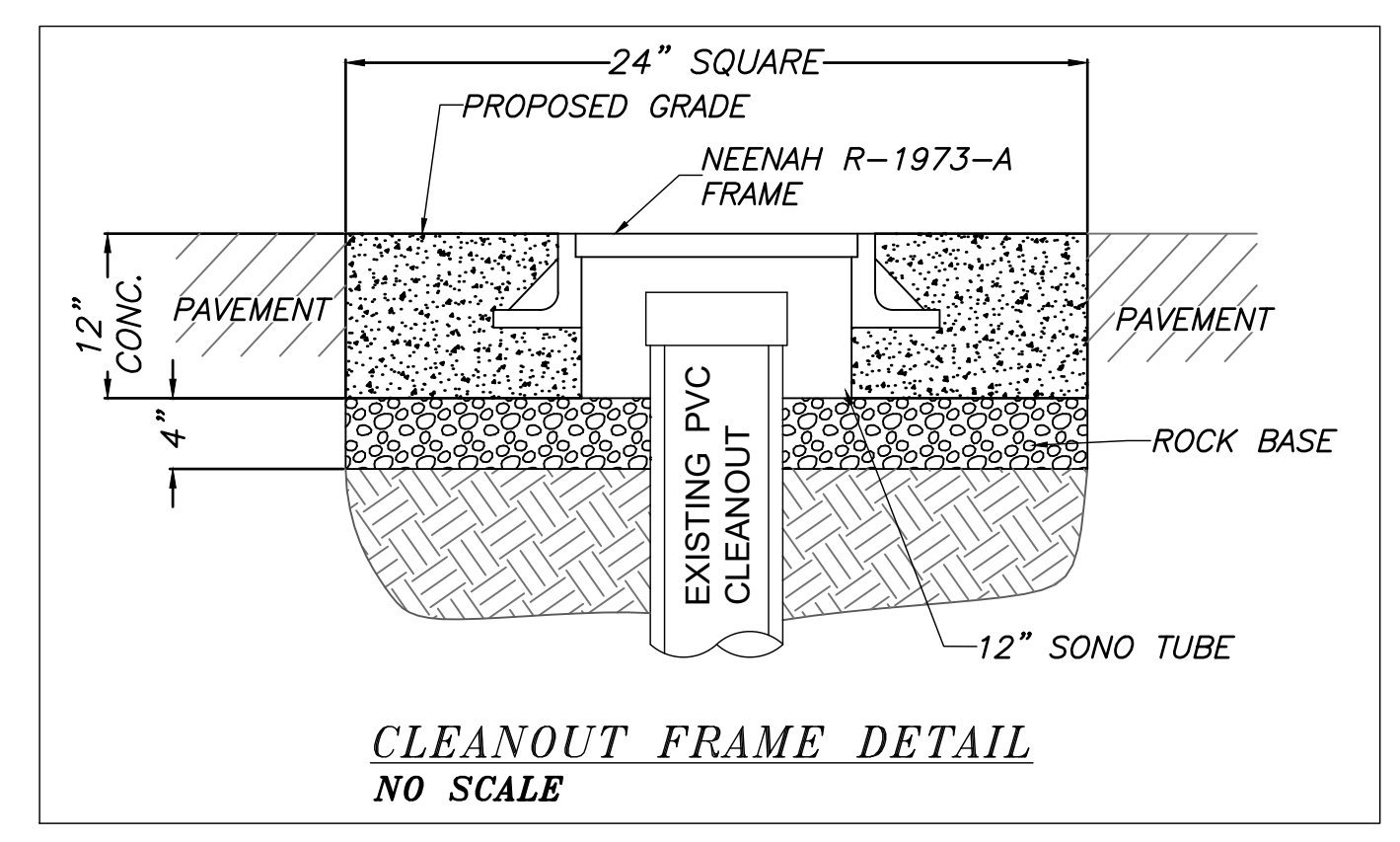

**Developer / Owner Information**  
STLMO Property, LLC c/o Jay Patel  
9911 Grandview Forest Ct.  
Sunset Hills, MO 63127  
618-210-1577

**Utilities Details**

P+Z No. 20-007711  
City No.

|               |             |
|---------------|-------------|
| SCALE:        | JOB: 32323  |
| DATE: 12-2020 | DWN. BY: RD |
| SC: AS        | REV:        |
| REV:          | SHEET       |

**C3.2**