

ASPHALT PAVEMENT (PARKING AREAS)

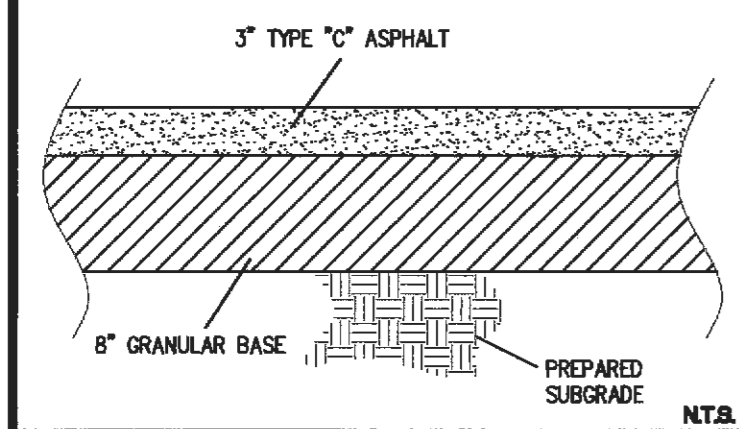

1. ASPHALT PAVEMENT SHALL BE COMPACTED TO 98% MAXIMUM DENSITY.
2. SUB GRADE AND BASE BENEATH PAVEMENTS SHALL BE COMPACTED TO ST. CHARLES COUNTY HIGHWAY DEPARTMENT SPECIFICATIONS. THE MOISTURE RANGE SHALL BE DETERMINED BY THE STANDARD OR MODIFIED PROCTOR DENSITY METHOD AASHTO T-99 AND WITHIN -2/+4 PERCENTAGE POINTS OF THE OPTIMUM MOISTURE CONTENT.

ASPHALT PAVEMENT (DRIVE AISLES)

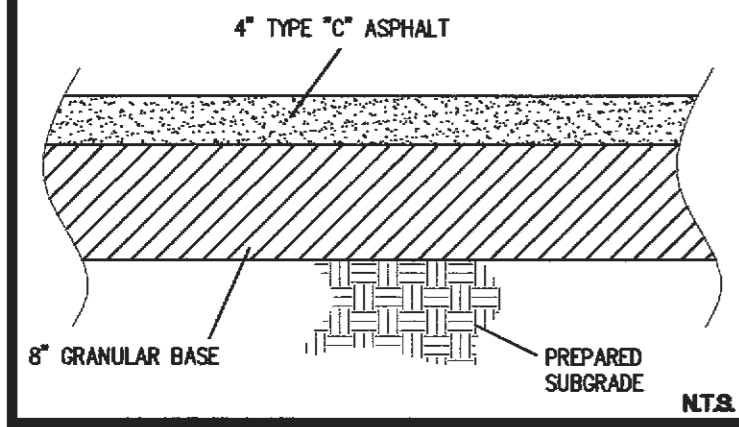

1. ASPHALT PAVEMENT SHALL BE COMPACTED TO 98% MAXIMUM DENSITY.
2. SUB GRADE AND BASE BENEATH PAVEMENTS SHALL BE COMPACTED TO ST. CHARLES COUNTY HIGHWAY DEPARTMENT SPECIFICATIONS. THE MOISTURE RANGE SHALL BE DETERMINED BY THE STANDARD OR MODIFIED PROCTOR DENSITY METHOD AASHTO T-99 AND WITHIN -2/+4 PERCENTAGE POINTS OF THE OPTIMUM MOISTURE CONTENT.

6" VERTICAL CONCRETE CURB (3" Type "C" with 8" Rock)

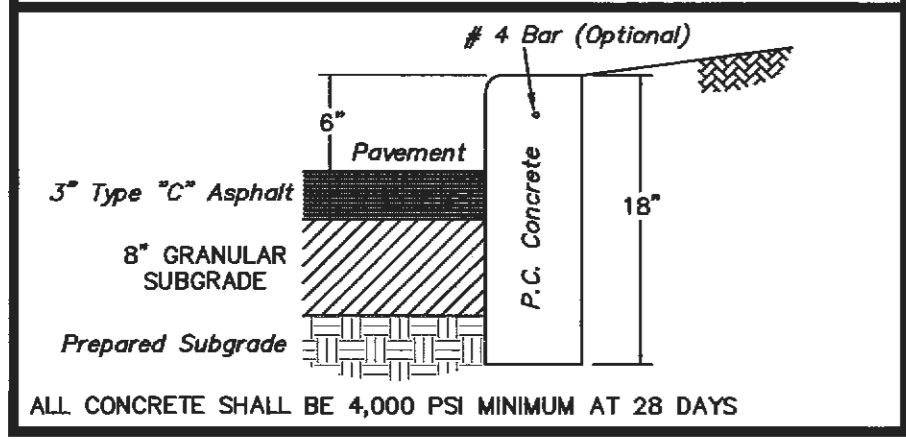

ALL CONCRETE SHALL BE 4,000 PSI MINIMUM AT 28 DAYS

CONCRETE PAVEMENT FOR TRASH ENCLOSURE

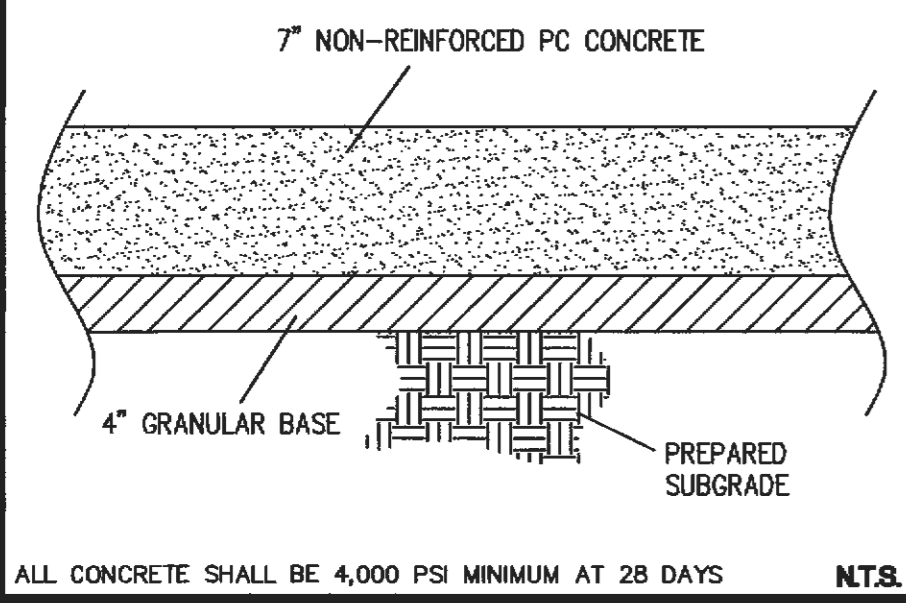

ALL CONCRETE SHALL BE 4,000 PSI MINIMUM AT 28 DAYS

DOWNCAST LIGHT STANDARD

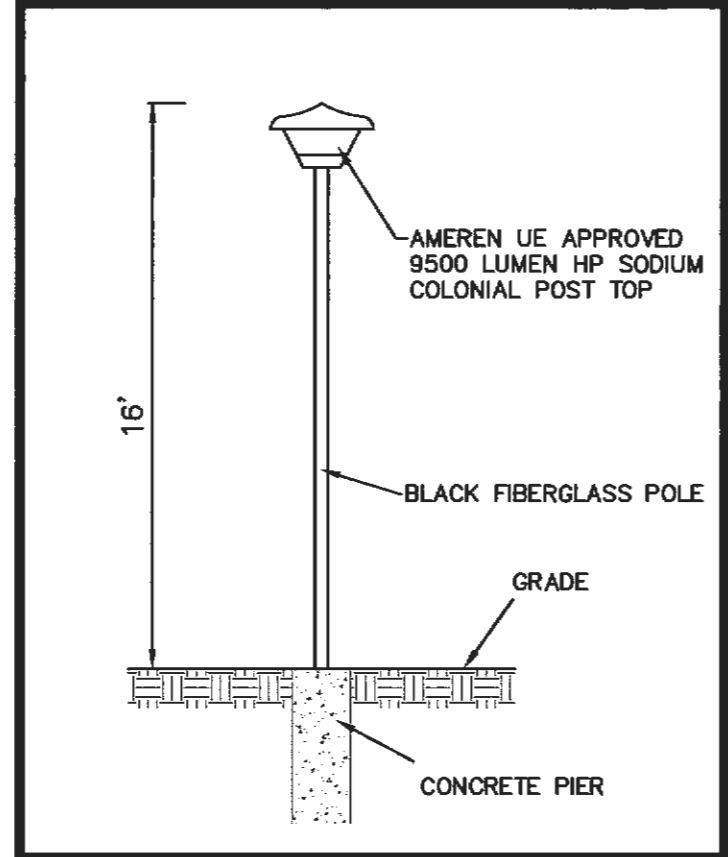

TYPICAL WROUGHT IRON FENCE (POOL FENCE)

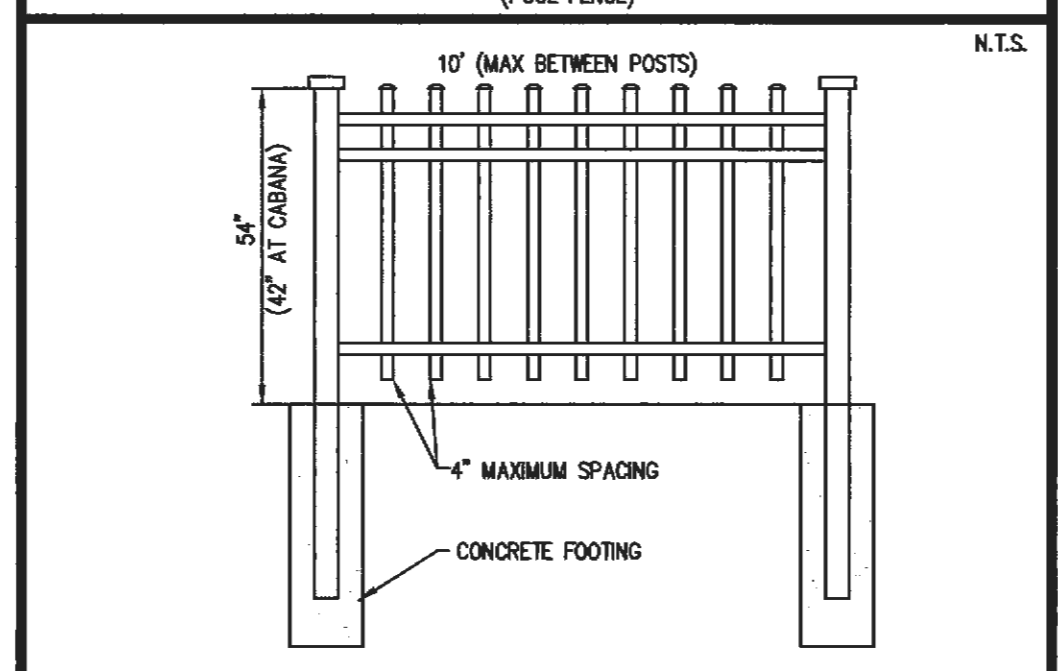

TRASH ENCLOSURE (PASSIVE ACCESS PLAN VIEW)

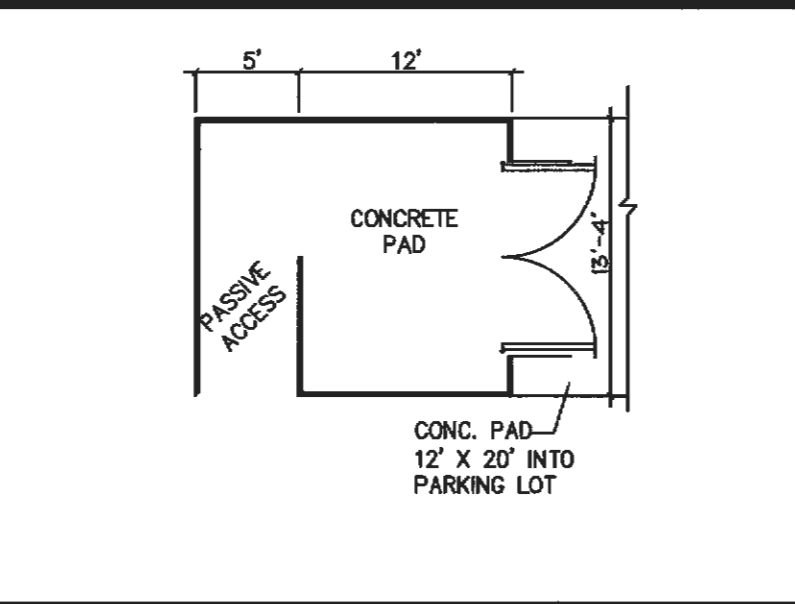

TRASH ENCLOSURE DETAIL

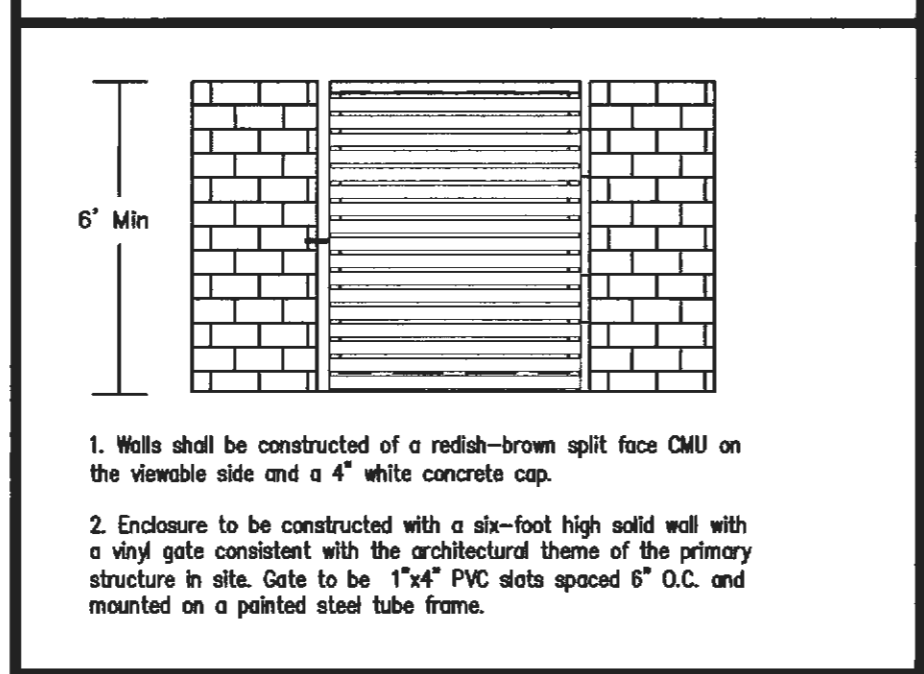

1. Walls shall be constructed of a redish-brown split face CMU on the viewable side and a 4" white concrete cap.
2. Enclosure to be constructed with a six-foot high solid wall with a vinyl gate consistent with the architectural theme of the primary structure in site. Gate to be 1"x4" PVC slats spaced 6" O.C. and mounted on a painted steel tube frame.

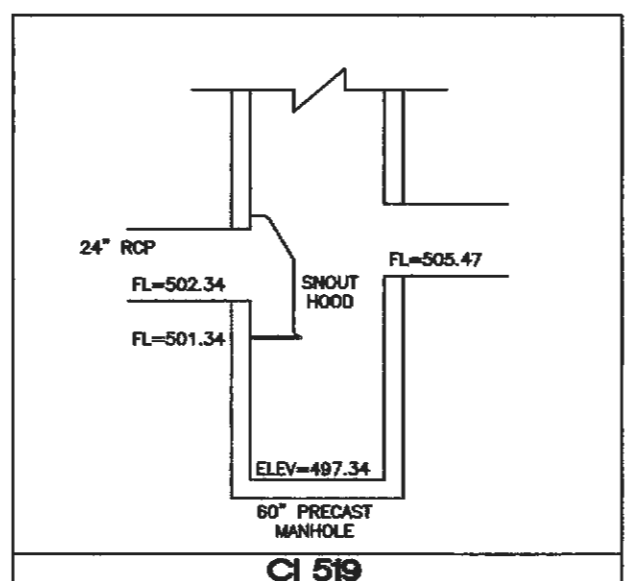
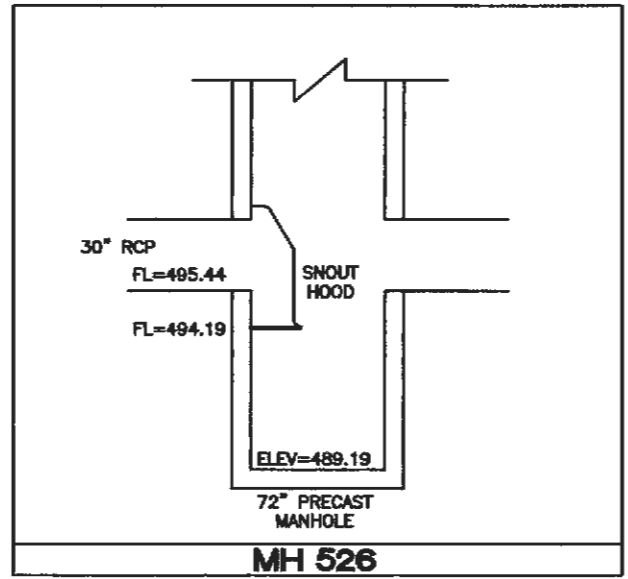
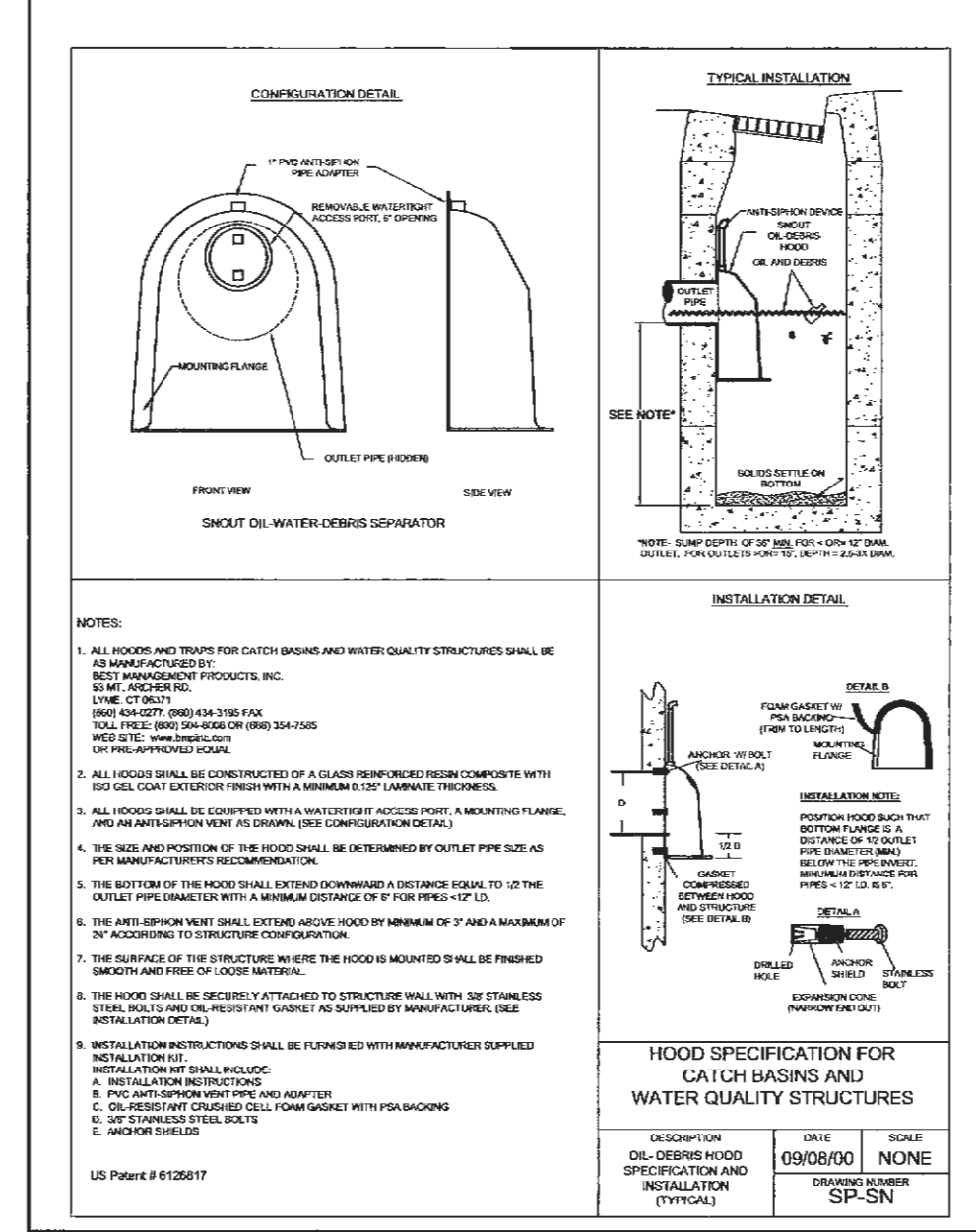

HANDICAPPED PARKING SIGN

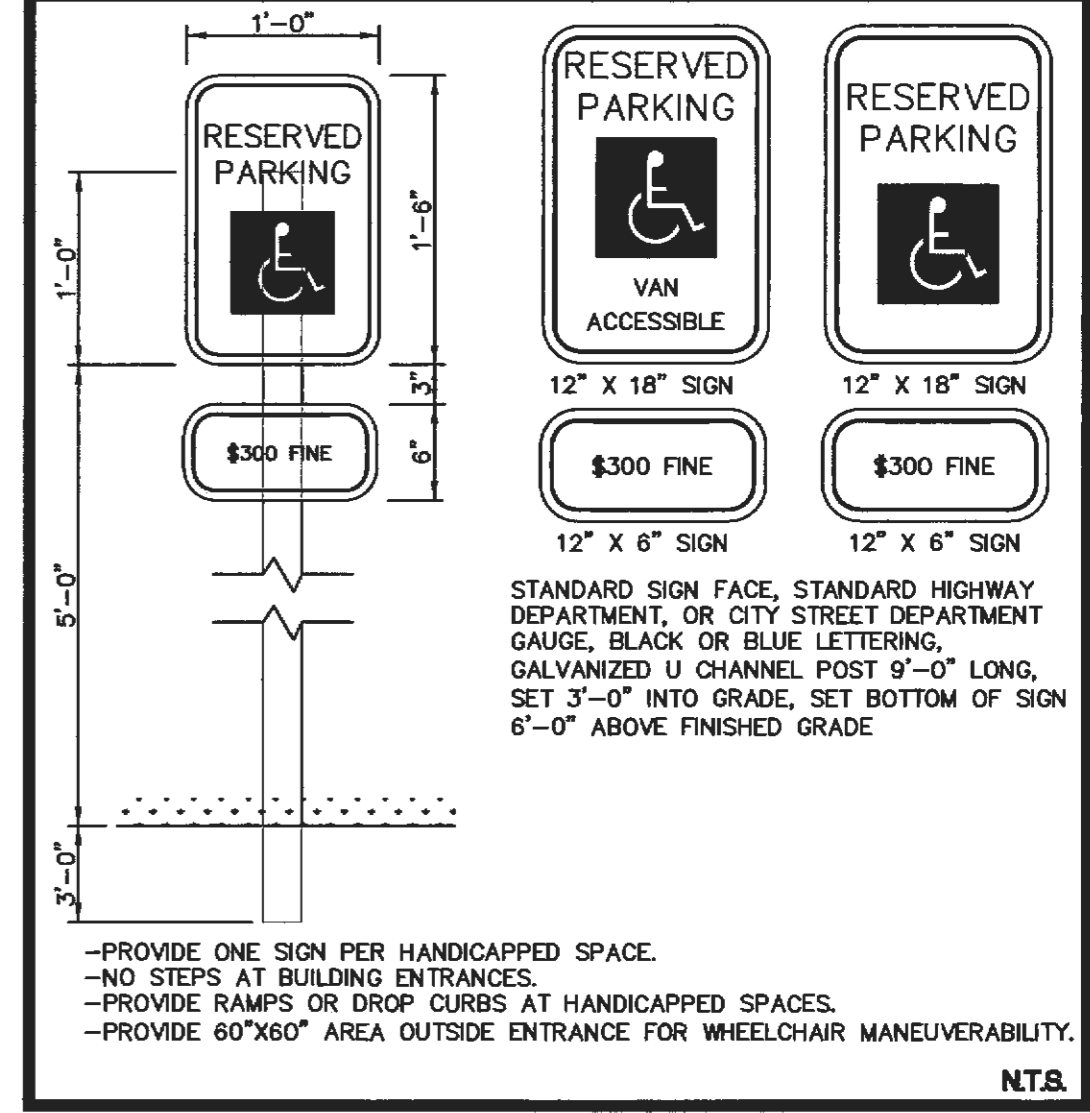

- PROVIDE ONE SIGN PER HANDICAPPED SPACE.
- NO STEPS AT BUILDING ENTRANCES.
- PROVIDE RAMPS OR DROP CURBS AT HANDICAPPED SPACES.
- PROVIDE 60"x60" AREA OUTSIDE ENTRANCE FOR WHEELCHAIR MANEUVERABILITY.

FLUSH HANDICAP RAMP DETAIL

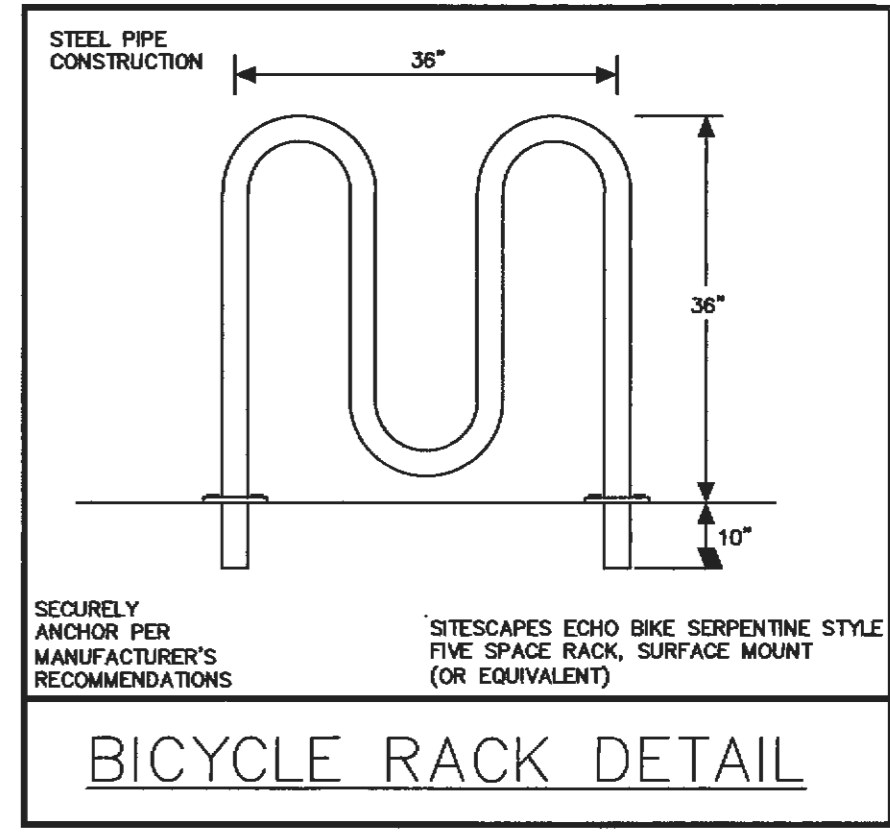
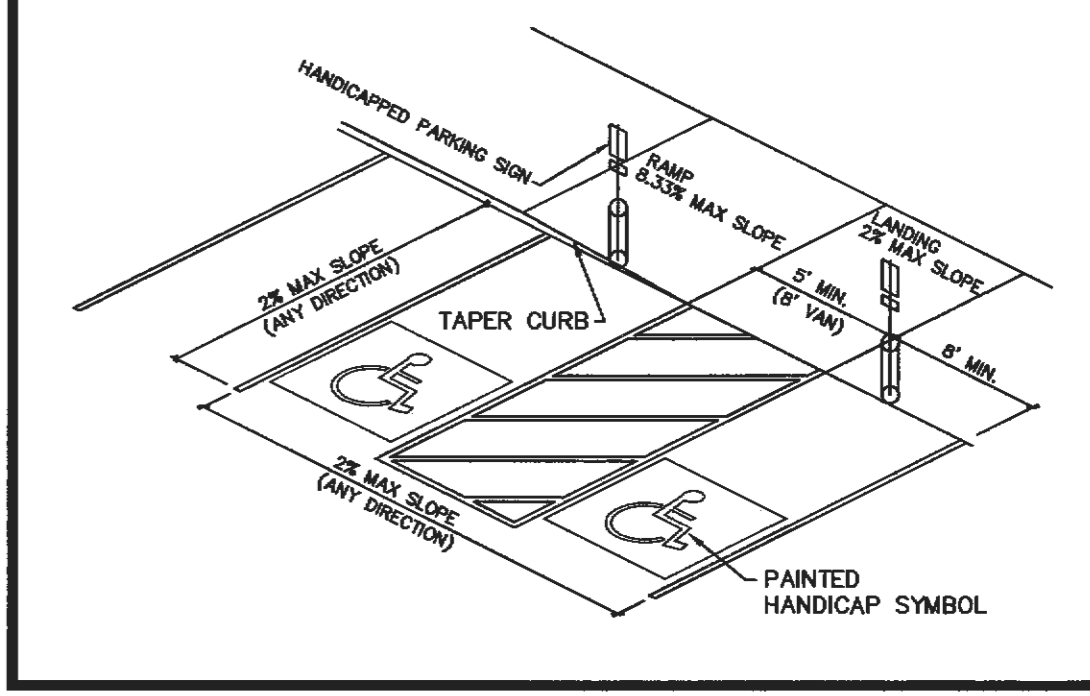

Call BEFORE you DIG
TOLL FREE
1-800-344-7483
MISSOURI ONE-CALL SYSTEM, INC.

UNDERGROUND UTILITIES HAVE BEEN PLOTTED FROM AVAILABLE INFORMATION AND THEREFORE THEIR LOCATIONS SHALL BE CONSIDERED APPROXIMATE ONLY. THE VERIFICATION OF THE LOCATION OF ALL UNDERGROUND UTILITIES, EITHER SHOWN OR NOT SHOWN ON THESE PLANS, SHALL BE THE RESPONSIBILITY OF THE CONTRACTOR, AND SHALL BE LOCATED PRIOR TO ANY GRADING AND/OR CONSTRUCTION OF IMPROVEMENTS.

PROJECT TITLE
BRAMBLETT HILLS APARTMENTS

THD DESIGN GROUP, INC.
"your solution for engineering and surveying"
COPYRIGHT 2011
148 CHESTERFIELD INDUSTRIAL BLVD., CHESTERFIELD, MO 63005
TEL. 636-394-2972

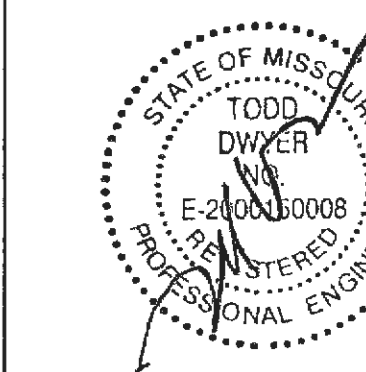

Developer / Owner Information:
Michael Towerman
TriStar Properties
13397 Lakefront Drive
Earth City, MO 63045

P+Z No: 3805.05.02
Approval Date: 02/0

City No.

Page No.