

BENDS	"8"	"10"	"12"	"14"	"16"
6"-11 1/4"	8" 15"	12" 24"	16" 36"	20" 48"	24" 60"
6"-22 1/2"	8" 18"	12" 24"	16" 36"	20" 48"	24" 60"
6"-45"	8" 21"	12" 24"	16" 36"	20" 48"	24" 60"
6"-90"	8" 24"	12" 24"	16" 36"	20" 48"	24" 60"
8"-11 1/4"	8" 20"	12" 24"	16" 36"	20" 48"	24" 60"
8"-22 1/2"	8" 22"	12" 24"	16" 36"	20" 48"	24" 60"
8"-45"	8" 24"	12" 24"	16" 36"	20" 48"	24" 60"
8"-90"	8" 26"	12" 24"	16" 36"	20" 48"	24" 60"
12"-11 1/4"	8" 30"	12" 24"	16" 36"	20" 48"	24" 60"
12"-22 1/2"	8" 32"	12" 24"	16" 36"	20" 48"	24" 60"
12"-45"	8" 34"	12" 24"	16" 36"	20" 48"	24" 60"
12"-90"	8" 36"	12" 24"	16" 36"	20" 48"	24" 60"
16"-11 1/4"	8" 38"	12" 24"	16" 36"	20" 48"	24" 60"
16"-22 1/2"	8" 40"	12" 24"	16" 36"	20" 48"	24" 60"
16"-45"	8" 42"	12" 24"	16" 36"	20" 48"	24" 60"
16"-90"	8" 44"	12" 24"	16" 36"	20" 48"	24" 60"
20"-11 1/4"	8" 46"	12" 24"	16" 36"	20" 48"	24" 60"
20"-22 1/2"	8" 48"	12" 24"	16" 36"	20" 48"	24" 60"
20"-45"	8" 50"	12" 24"	16" 36"	20" 48"	24" 60"
20"-90"	8" 52"	12" 24"	16" 36"	20" 48"	24" 60"
24"-11 1/4"	8" 54"	12" 24"	16" 36"	20" 48"	24" 60"
24"-22 1/2"	8" 56"	12" 24"	16" 36"	20" 48"	24" 60"
24"-45"	8" 58"	12" 24"	16" 36"	20" 48"	24" 60"
24"-90"	8" 60"	12" 24"	16" 36"	20" 48"	24" 60"
30"-11 1/4"	8" 62"	12" 24"	16" 36"	20" 48"	24" 60"
30"-22 1/2"	8" 64"	12" 24"	16" 36"	20" 48"	24" 60"
30"-45"	8" 66"	12" 24"	16" 36"	20" 48"	24" 60"
30"-90"	8" 68"	12" 24"	16" 36"	20" 48"	24" 60"

TEES	"6"	"8"	"10"	"12"	"14"	"16"
6"x6"x6"	12"	24"	36"	48"	60"	72"
6"x8"x6"	12"	24"	36"	48"	60"	72"
6"x10"x6"	12"	24"	36"	48"	60"	72"
6"x12"x6"	12"	24"	36"	48"	60"	72"
6"x14"x6"	12"	24"	36"	48"	60"	72"
6"x16"x6"	12"	24"	36"	48"	60"	72"
8"x8"x8"	12"	24"	36"	48"	60"	72"
8"x10"x8"	12"	24"	36"	48"	60"	72"
8"x12"x8"	12"	24"	36"	48"	60"	72"
8"x14"x8"	12"	24"	36"	48"	60"	72"
8"x16"x8"	12"	24"	36"	48"	60"	72"
10"x10"x10"	12"	24"	36"	48"	60"	72"
10"x12"x10"	12"	24"	36"	48"	60"	72"
10"x14"x10"	12"	24"	36"	48"	60"	72"
10"x16"x10"	12"	24"	36"	48"	60"	72"

- NOTES:
 1. 2" & 4" FITTINGS EQUIVALENT TO 6" FITTINGS.
 2. TAPPING SLEEVES TO HAVE BACKING BLOCKS SAME SIZE AS REQUIRED FOR TEES.
 3. "L" = TOTAL LENGTH OF FITTING MINUS CLEARANCE FOR BELLS.

INTERNAL WATER PRESSURE 6" through 12"=200 psi
 INTERNAL WATER PRESSURE 16" through 30"=210 psi
 BEARING PRESSURE OF SOIL=2000 psi

BACKING BLOCKS
 NOT TO SCALE

CITY OF O'FALLON
 ENGINEERING DEPARTMENT
 O'FALLON, MISSOURI

**BACKING BLOCK
 DETAILS AND LOCATIONS**

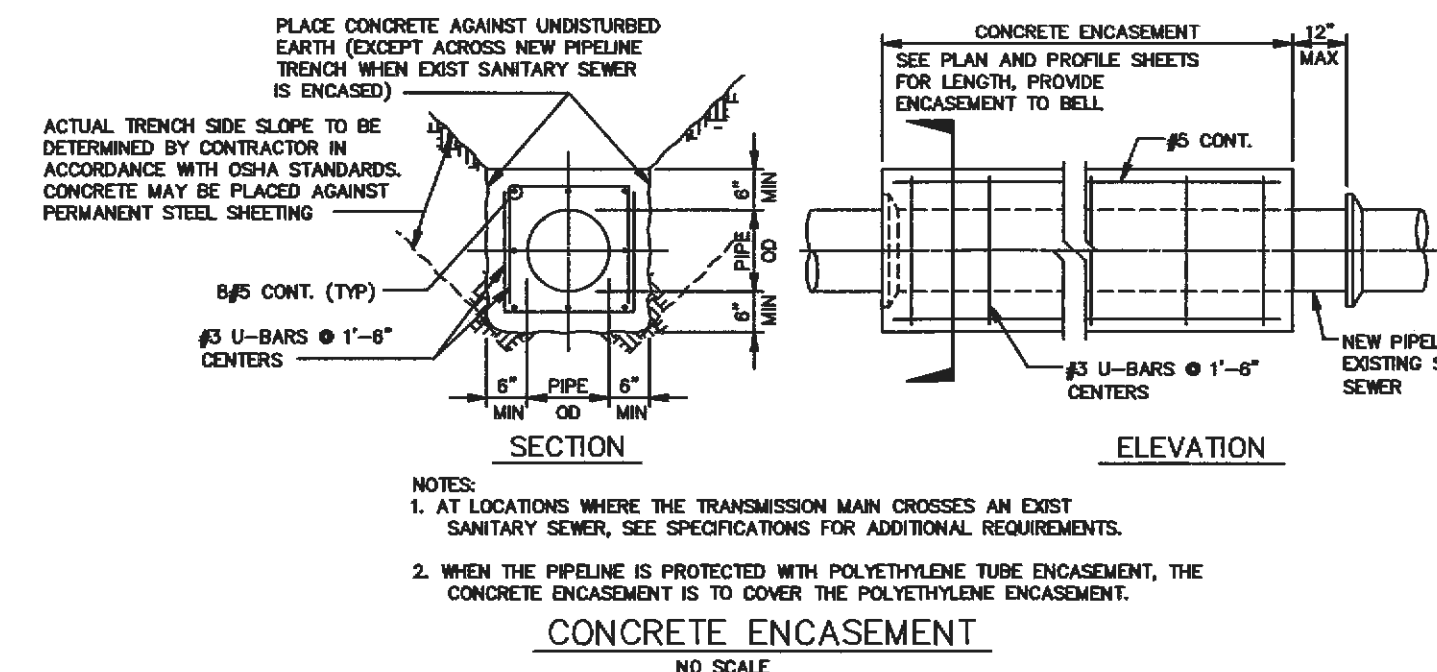

CITY OF O'FALLON
 ENGINEERING DEPARTMENT
 O'FALLON, MISSOURI

**CONCRETE ENCASEMENT
 DETAILS**

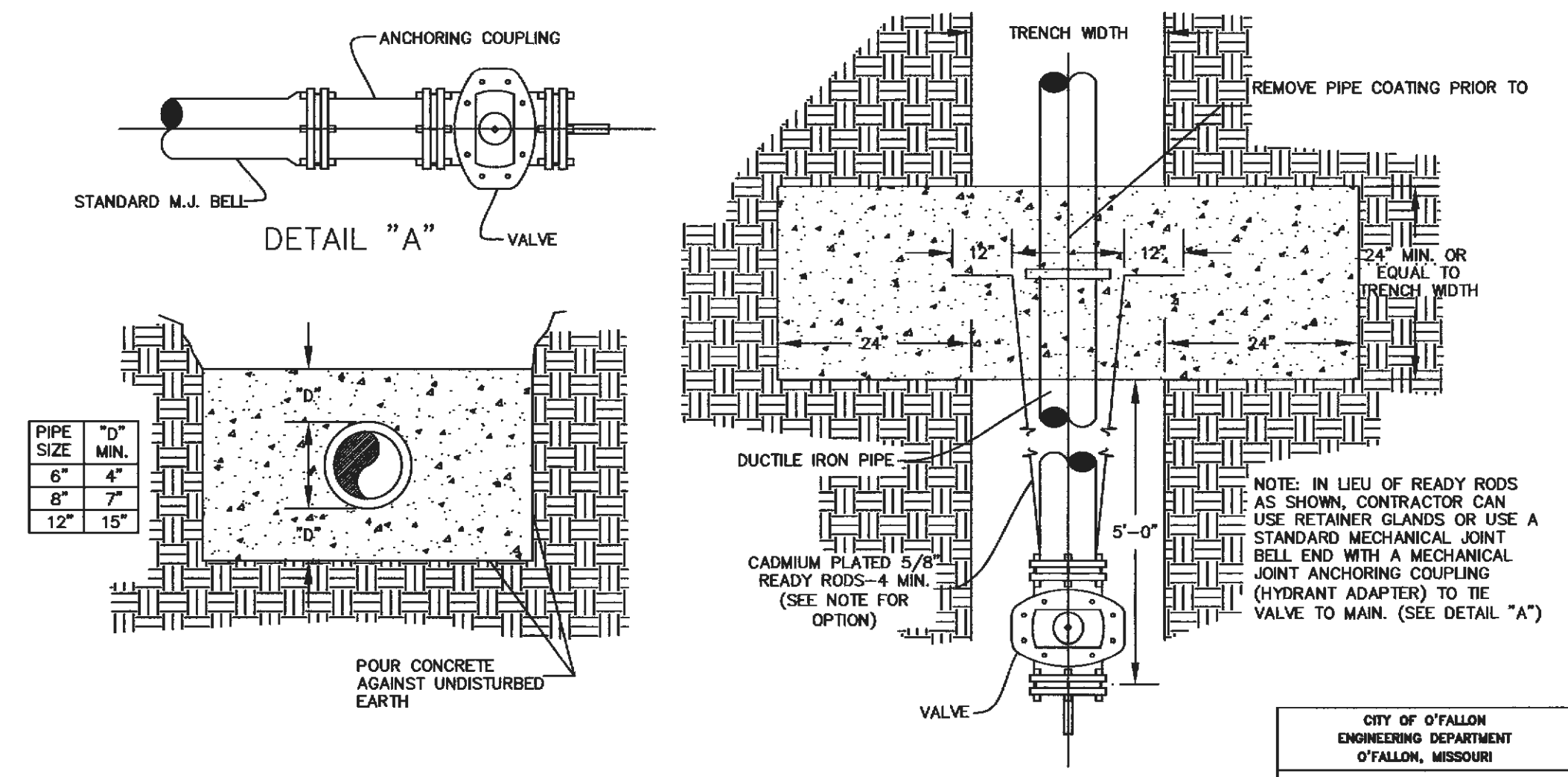

CITY OF O'FALLON
 ENGINEERING DEPARTMENT
 O'FALLON, MISSOURI

**STRADDLE BLOCK
 DETAILS**

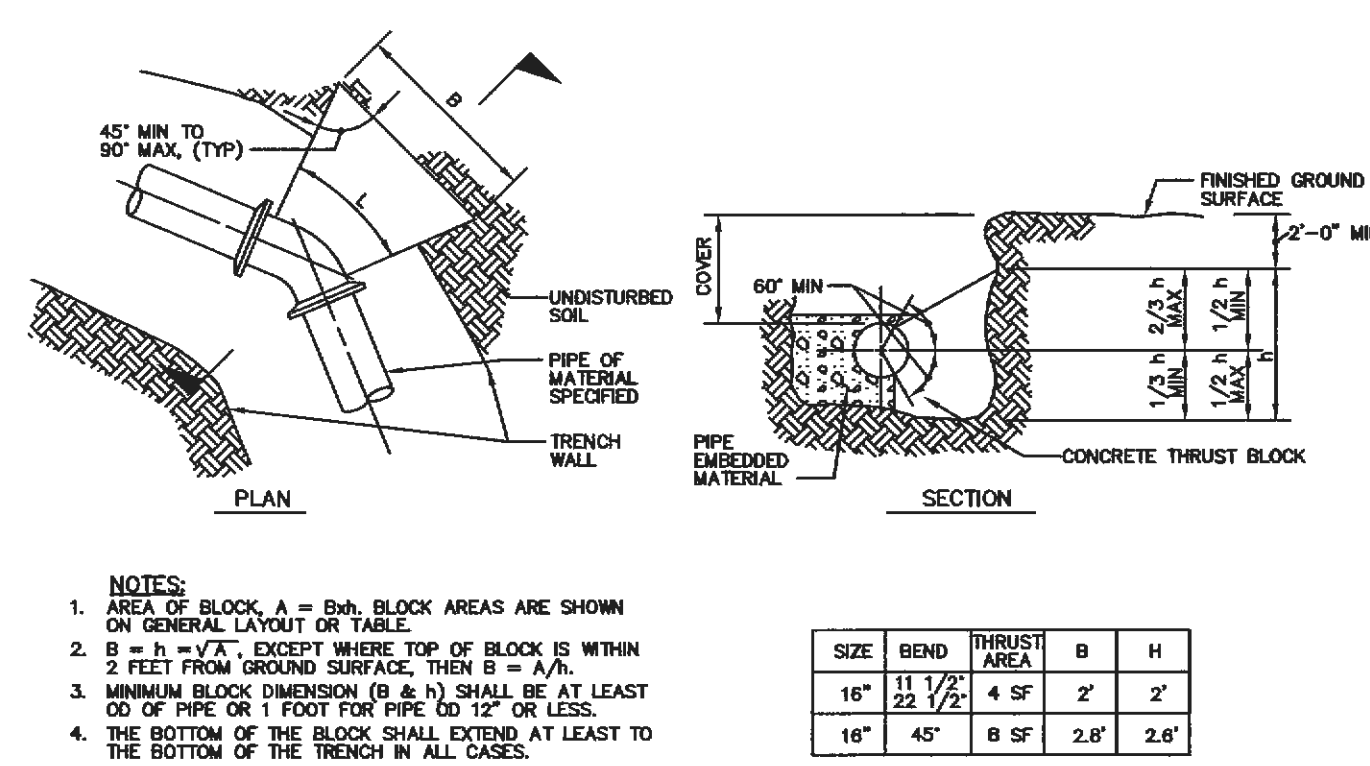

CONCRETE THRUST BLOCKING
 NOT TO SCALE

CITY OF O'FALLON
 ENGINEERING DEPARTMENT
 O'FALLON, MISSOURI

**CONCRETE THRUST
 BLOCKING DETAILS**

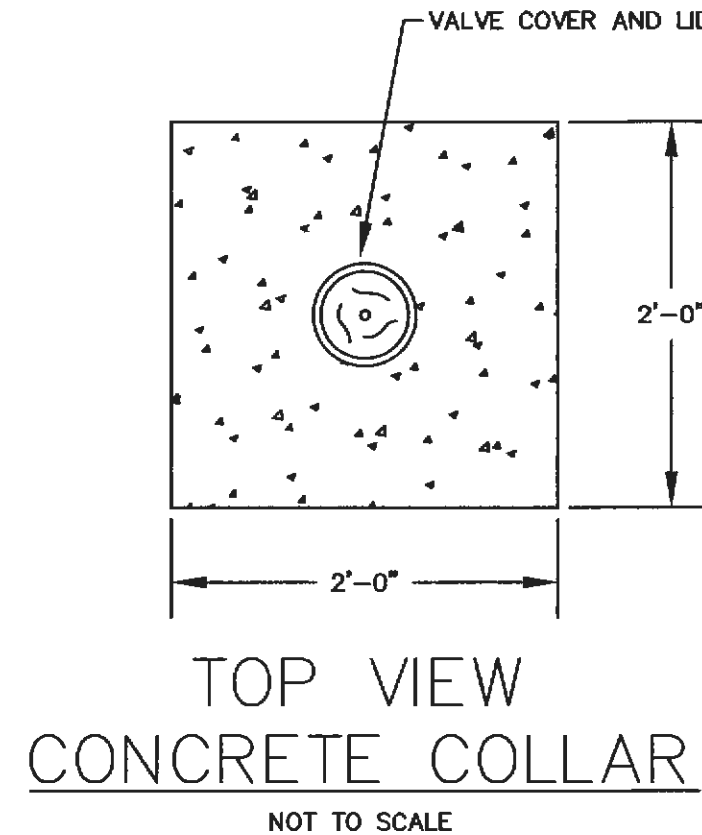

CITY OF O'FALLON
 ENGINEERING DEPARTMENT
 O'FALLON, MISSOURI

**CONCRETE
 COLLAR DETAIL**

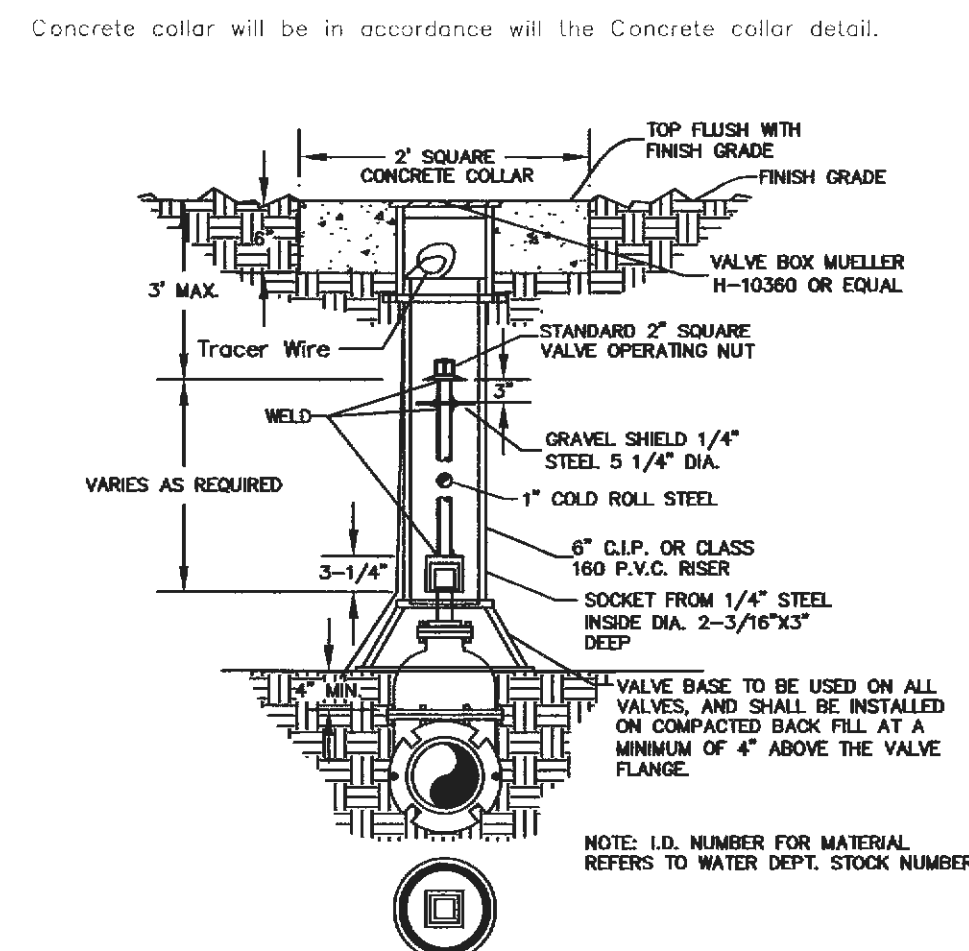

WATER VALVE DETAIL
 NOT TO SCALE

CITY OF O'FALLON
 ENGINEERING DEPARTMENT
 O'FALLON, MISSOURI

**WATER
 VALVE DETAIL**

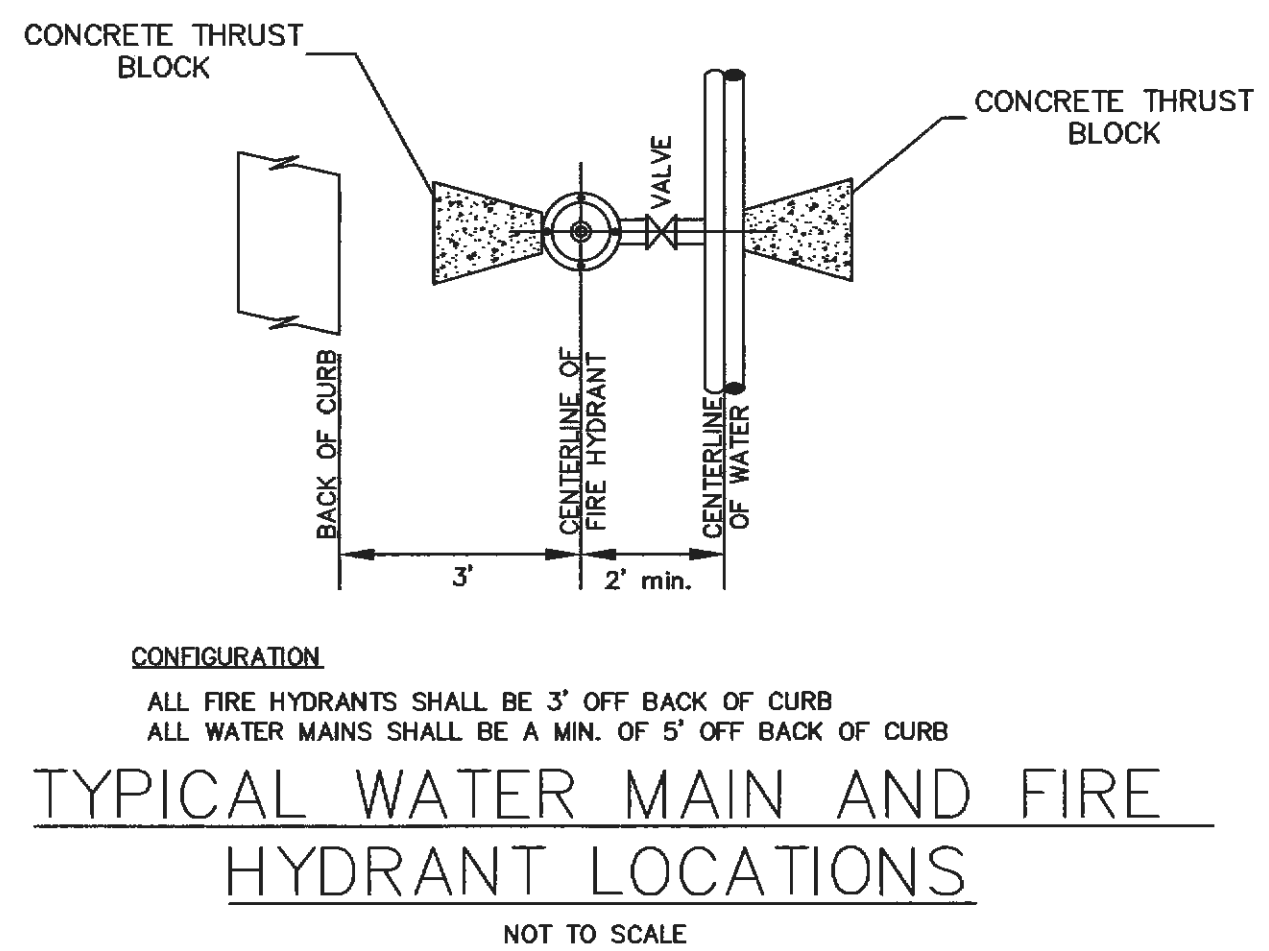

CITY OF O'FALLON
 ENGINEERING DEPARTMENT
 O'FALLON, MISSOURI

**WATER MAIN
 FIRE HYDRANT DETAIL**

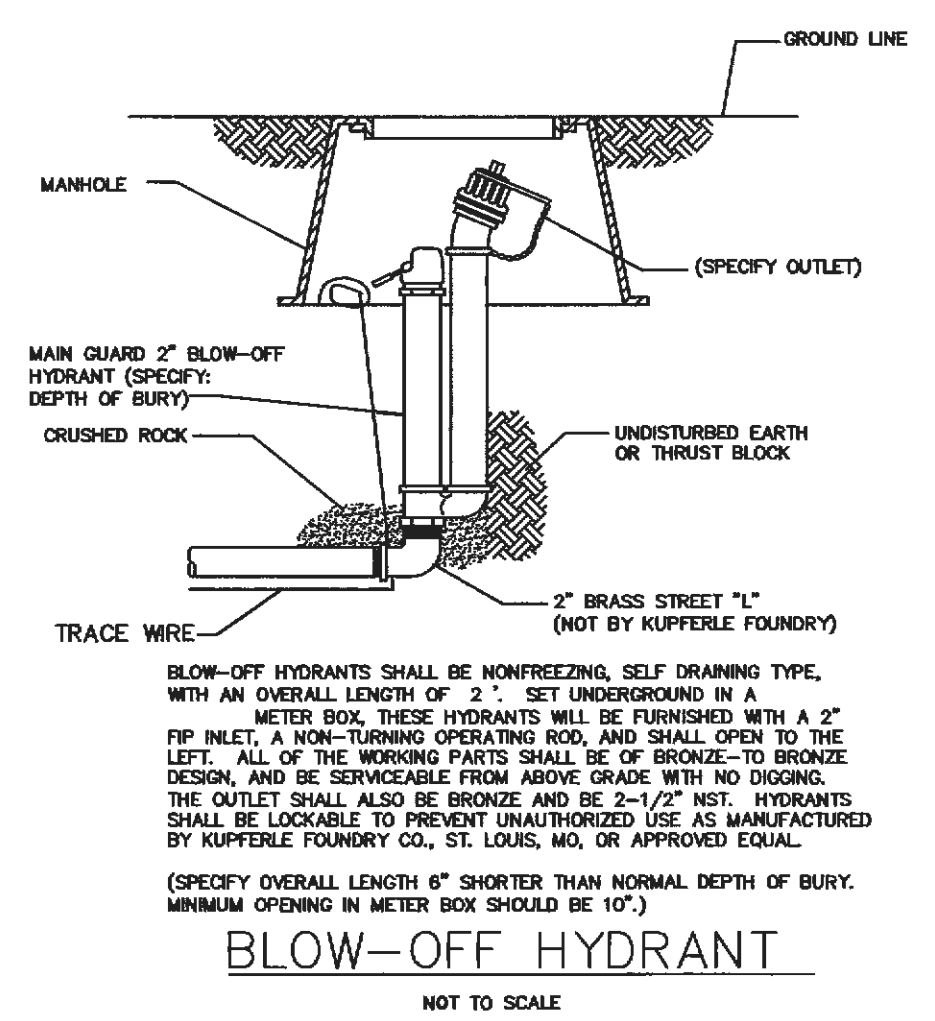

CITY OF O'FALLON
 ENGINEERING DEPARTMENT
 O'FALLON, MISSOURI

**BLOW-OFF
 HYDRANT DETAIL**

THD DESIGN GROUP, INC.
 "your solution for engineering and surveying"
 COPYRIGHT 2011
 148 CHESTERFIELD INDUSTRIAL BLVD, CHESTERFIELD, MO 63005
 TEL: 636-254-3972
 FAX: 636-254-3977
 WEB: THDDSGROUP.COM

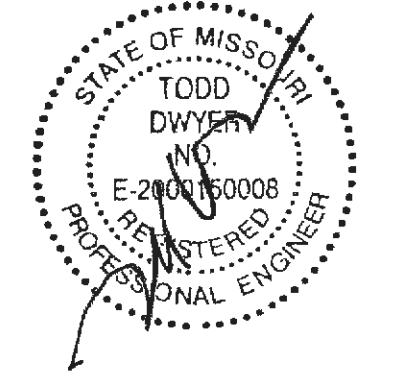

Developer / Owner Information:
 Michael Towerman
 Tristar Properties
 1397 Lakefront Drive
 Earth City, MO 63045

P+Z No: 3805.05.02
 Approval Date: 02/05/2015
 City No.

Page No.
 26 OF 28

CITY OF O'FALLON WATER DETAILS