

A PIPE TRENCH DETAIL NOT TO SCALE

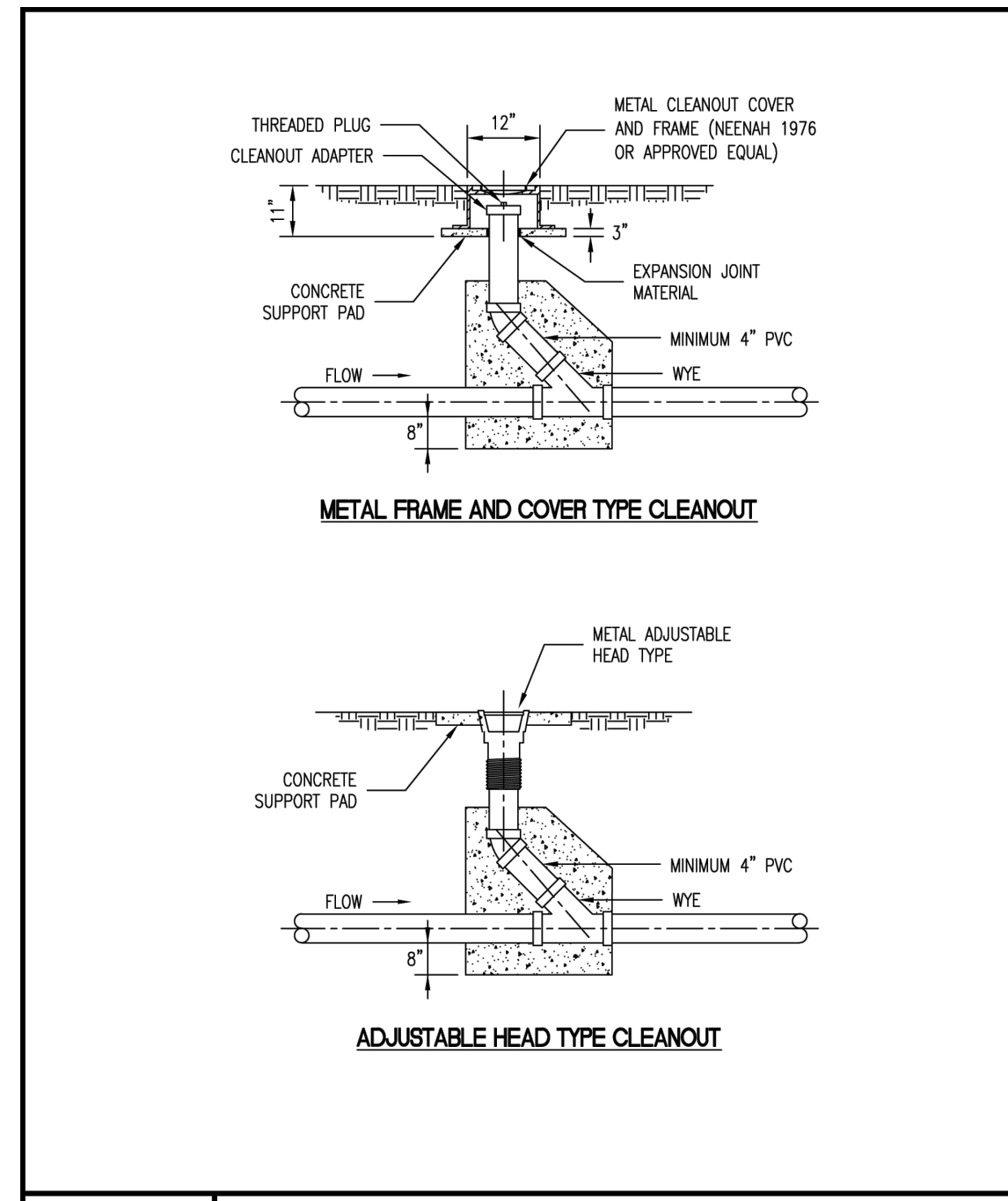

Duckett Creek Sanitary District  
TYPICAL SANITARY SEWER CLEANOUT DETAIL  
B SANITARY SEWER CLEANOUT DETAIL NOT TO SCALE

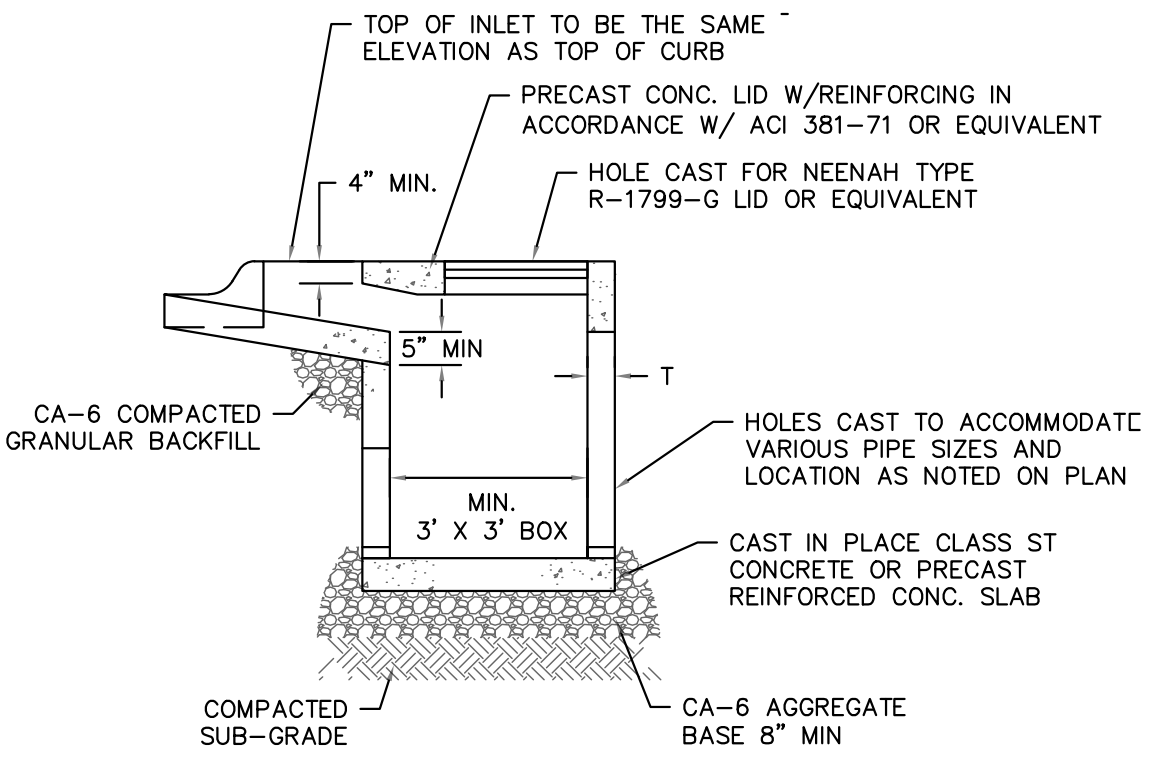
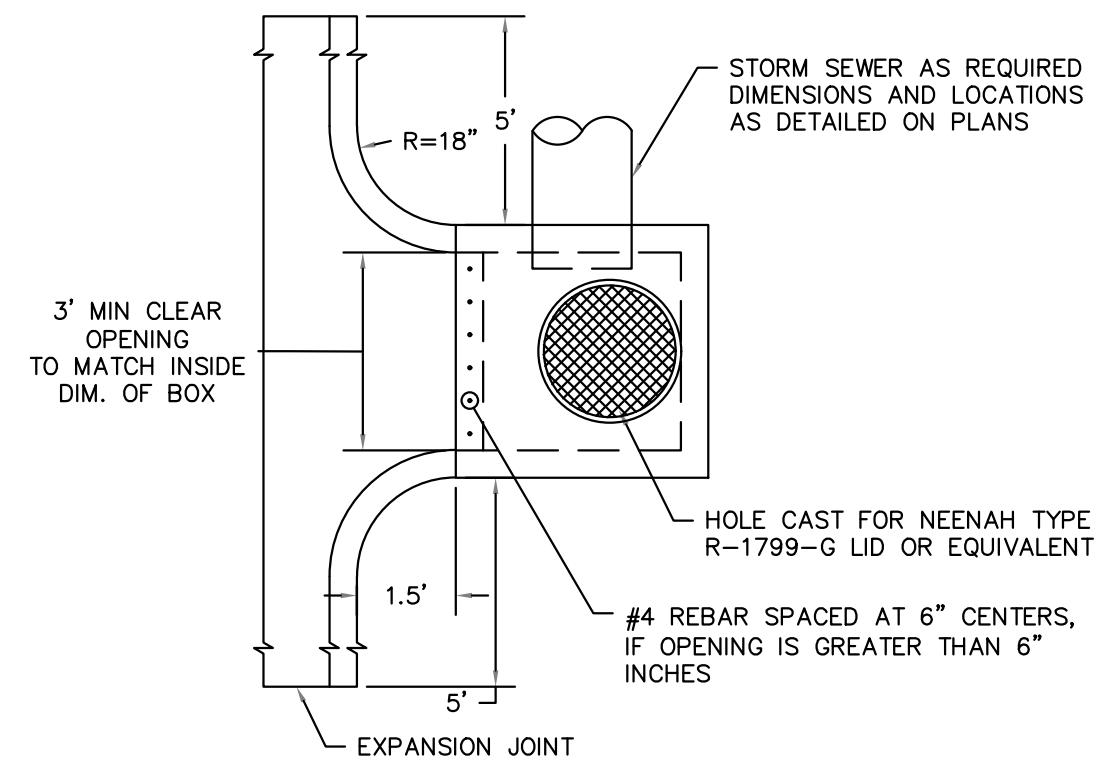

NOTE:  
1. PRE-CAST INLET SHALL CONFORM TO ASTM C-478  
2. ALL INLET BOXES WITH STORM SEWER PIPES HAVE INNER DIMENSIONS OF 12" PLUS THE DIAMETER OF THE PIPE  
C OPEN THROAT INLET DETAIL NOT TO SCALE

ADS FLEXSTORM PURE INLET FILTERS

Diagram D: FLEXSTORM PURE INLET FILTER DETAIL. Includes diagrams of round and square/rectangular filters, and tables for specifications and installation instructions.

ROUND FILTER FRAME PART NUMBER			OPEN THROAT FRAME PART NUMBER			SQUARE/RECTANGULAR FILTER FRAME PART NUMBER		
Clear Opening Size	Frame P/N	Minimum Bypass Flow Rate (CFS)	Clear Opening Size	Frame P/N	Minimum Bypass Flow Rate (CFS)	Clear Opening Size	Frame P/N	Minimum Bypass Flow Rate (CFS)
Small: 10.0" - 16.0" Dia.	62SHDR	1.6	Up to 4" Width (1 Piece Set)	62HDWM1	2.4	Small: Up to 64" Perimeter	62SHD	2.4
Medium: 16.1" - 24.0" Dia.	62MHDR	2.7	4" - 8" Width (2 Piece Set)	62HDWM2	3.5	Medium: 65" - 96" Perimeter	62MHD	3.5
Large: 24.1" - 36.0" Dia.	62LHDR	3.8	8" - 12" Width (3 Piece Set)	62HDWM3	5	Large: 96.1" - 120.0" Perimeter	62LHD	5
			12" - 16" Width (4 Piece Set)	62HDWM4	7.2	Extra-Large: 120.1" or Greater Perimeter	62XLHD	7.2

INSTALLATION INSTRUCTIONS:  
1. REMOVE GRATE.  
2. CLEAN GRATE LEDGE.  
3. SET INLET FILTER ON ONTO LOAD BEARING LEDGE OF STRUCTURE.  
4. REPLACE GRATE.

ADVANCED DRAINAGE SYSTEMS FLEXSTORM INLET FILTERS, INC. WWW.ADSPIPE.COM PH. 1-800-821-6710

D FLEXSTORM PURE INLET FILTER DETAIL NOT TO SCALE

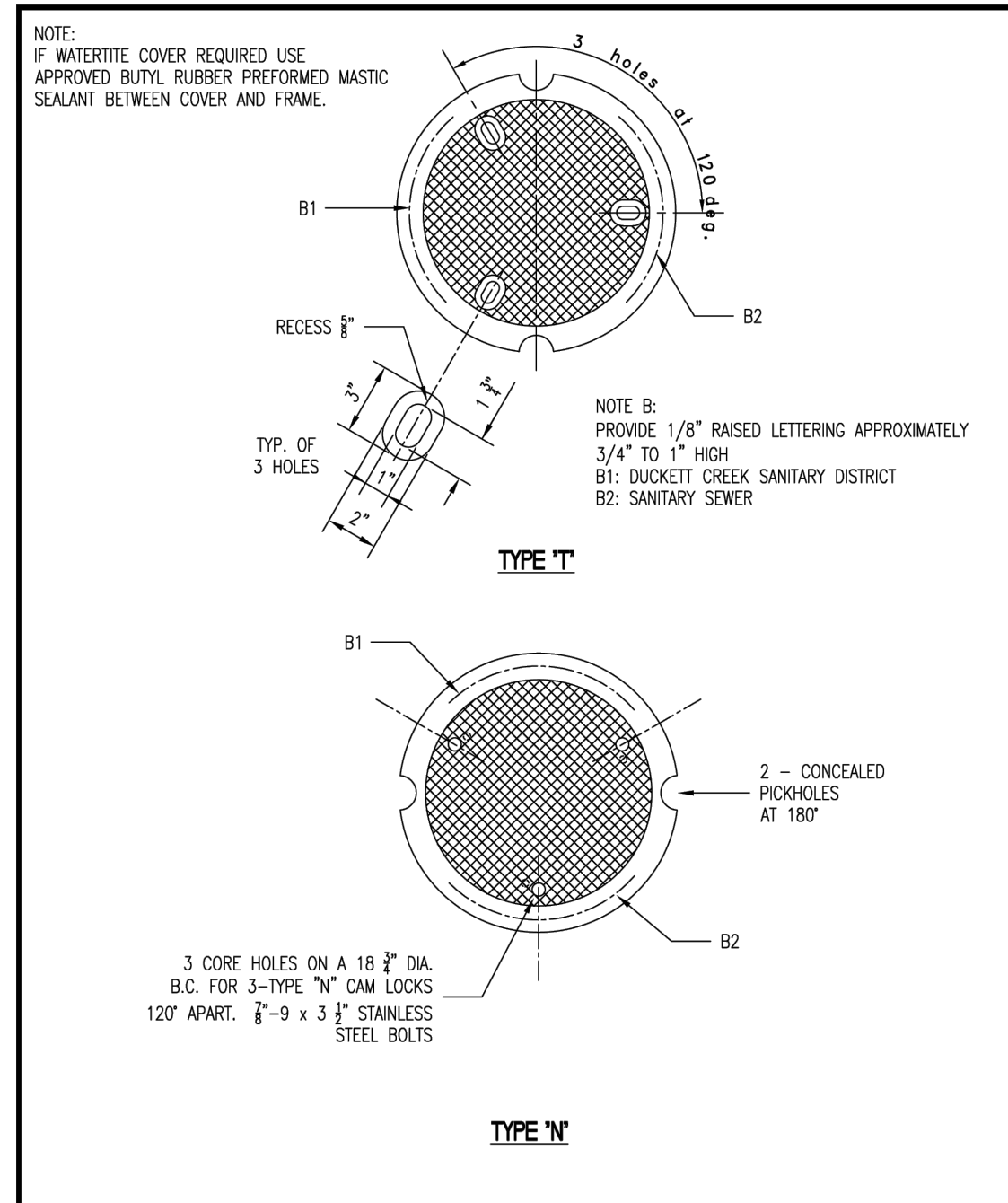

Duckett Creek Sanitary District  
CAST IRON MANHOLE COVERS (LOCK TYPE)  
E CAST IRON MANHOLE COVERS (LOCK TYPE) NOT TO SCALE

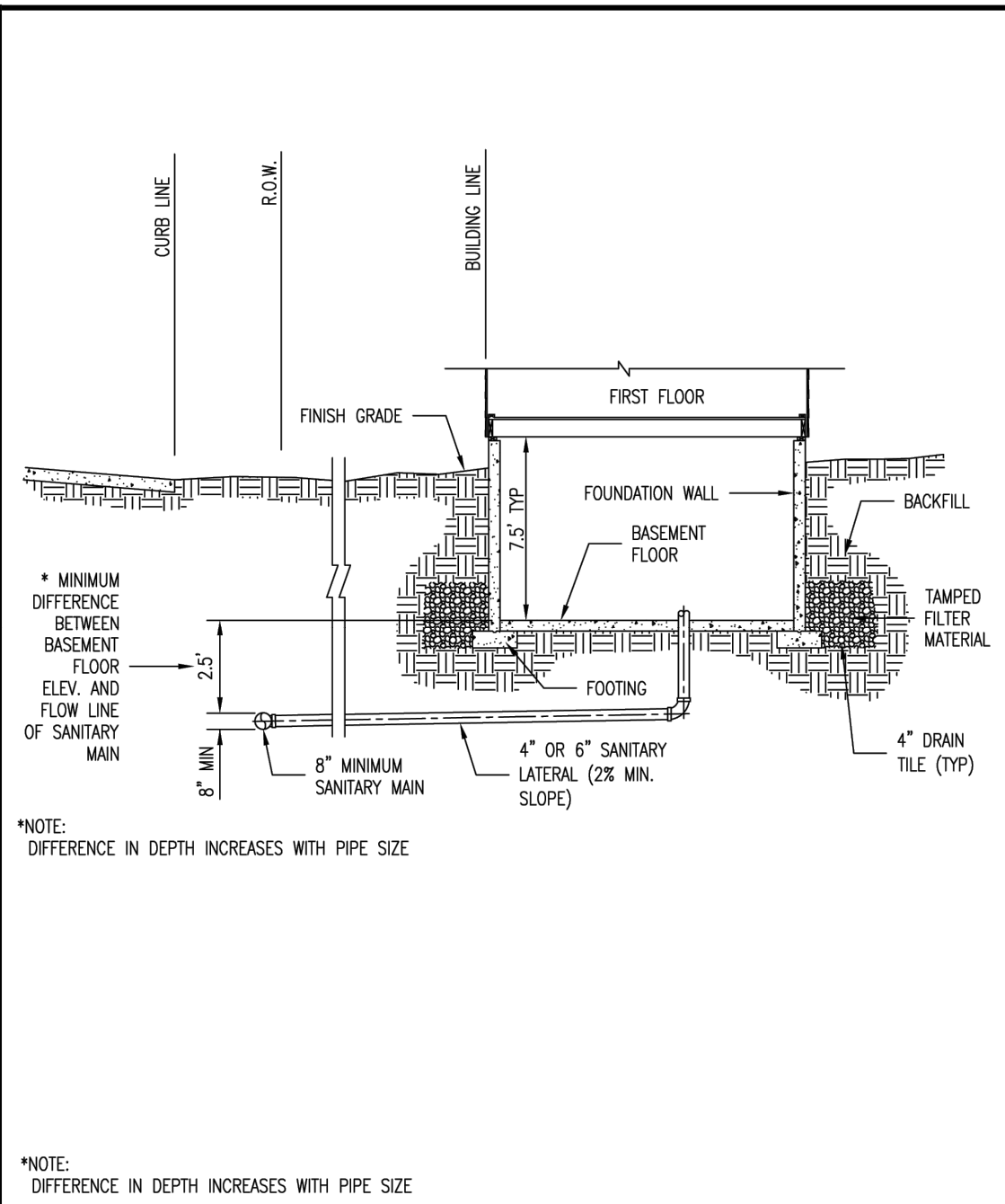

Duckett Creek Sanitary District  
TYPICAL SANITARY SEWER LATERAL PROFILE  
F TYPICAL SANITARY SEWER LATERAL PROFILE NOT TO SCALE

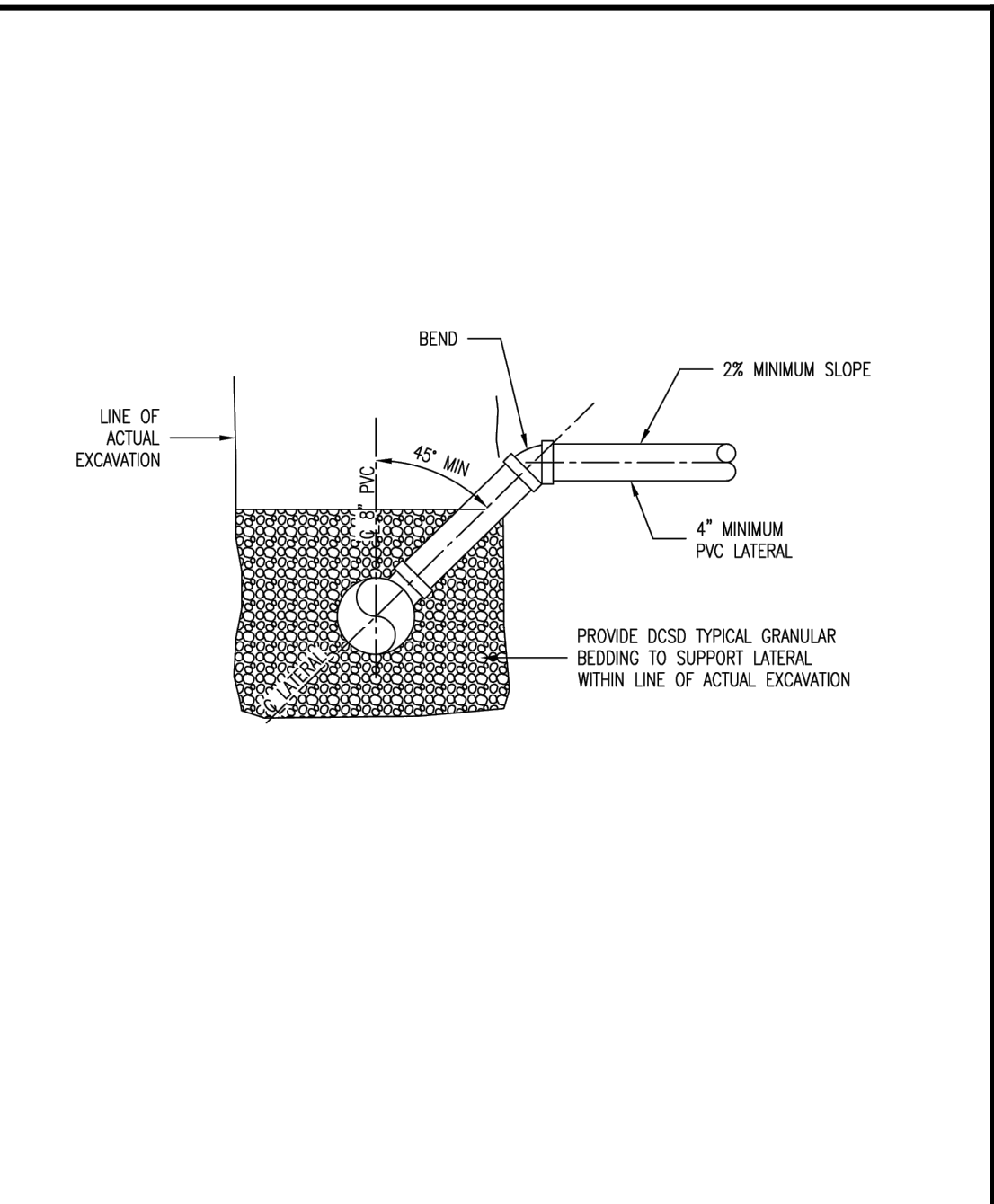

Duckett Creek Sanitary District  
SANITARY SEWER LATERAL RISER DETAIL  
G SANITARY SEWER LATERAL RISER DETAIL NOT TO SCALE

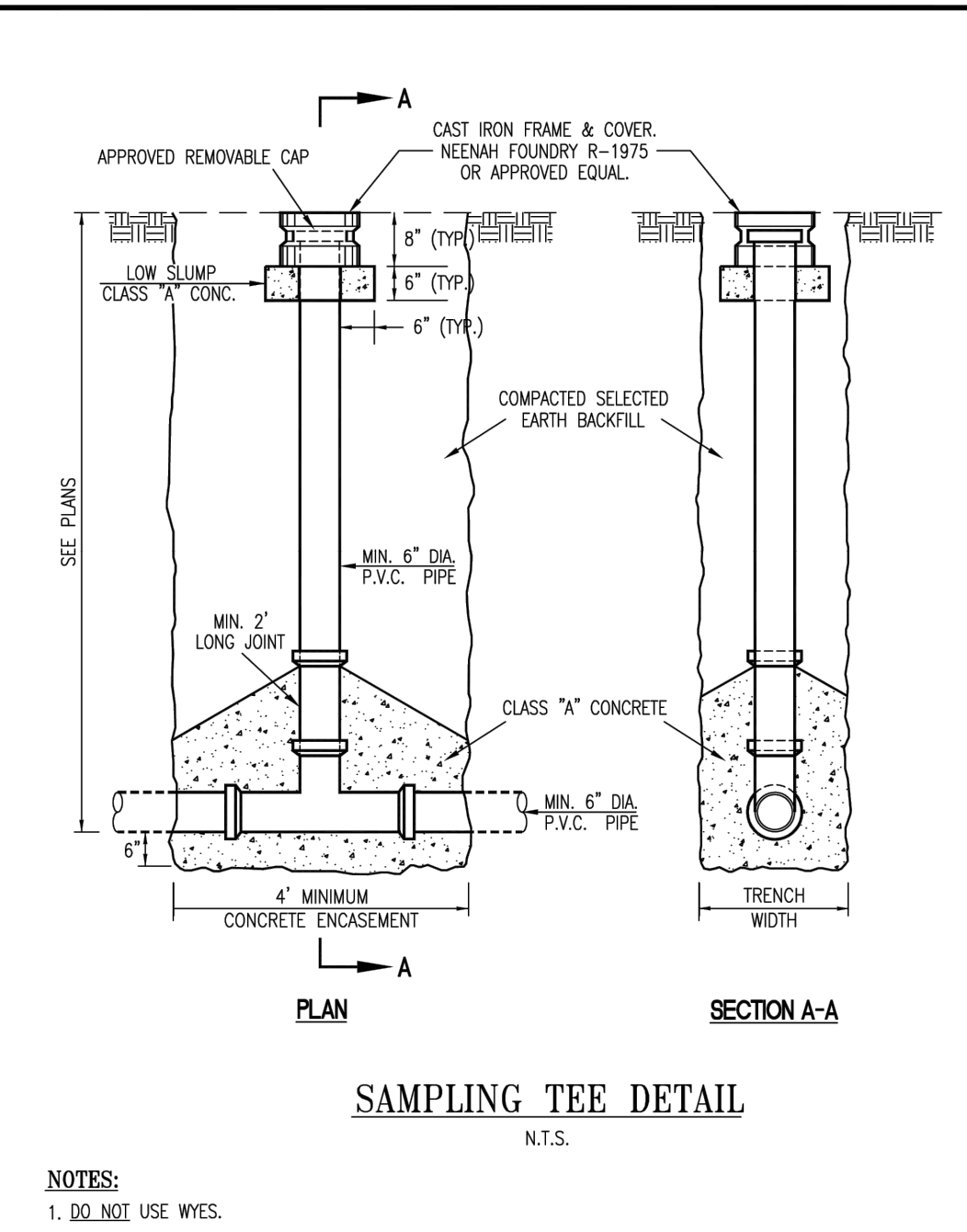

Duckett Creek Sanitary District  
SAMPLING TEE  
H SAMPLING TEE NOT TO SCALE

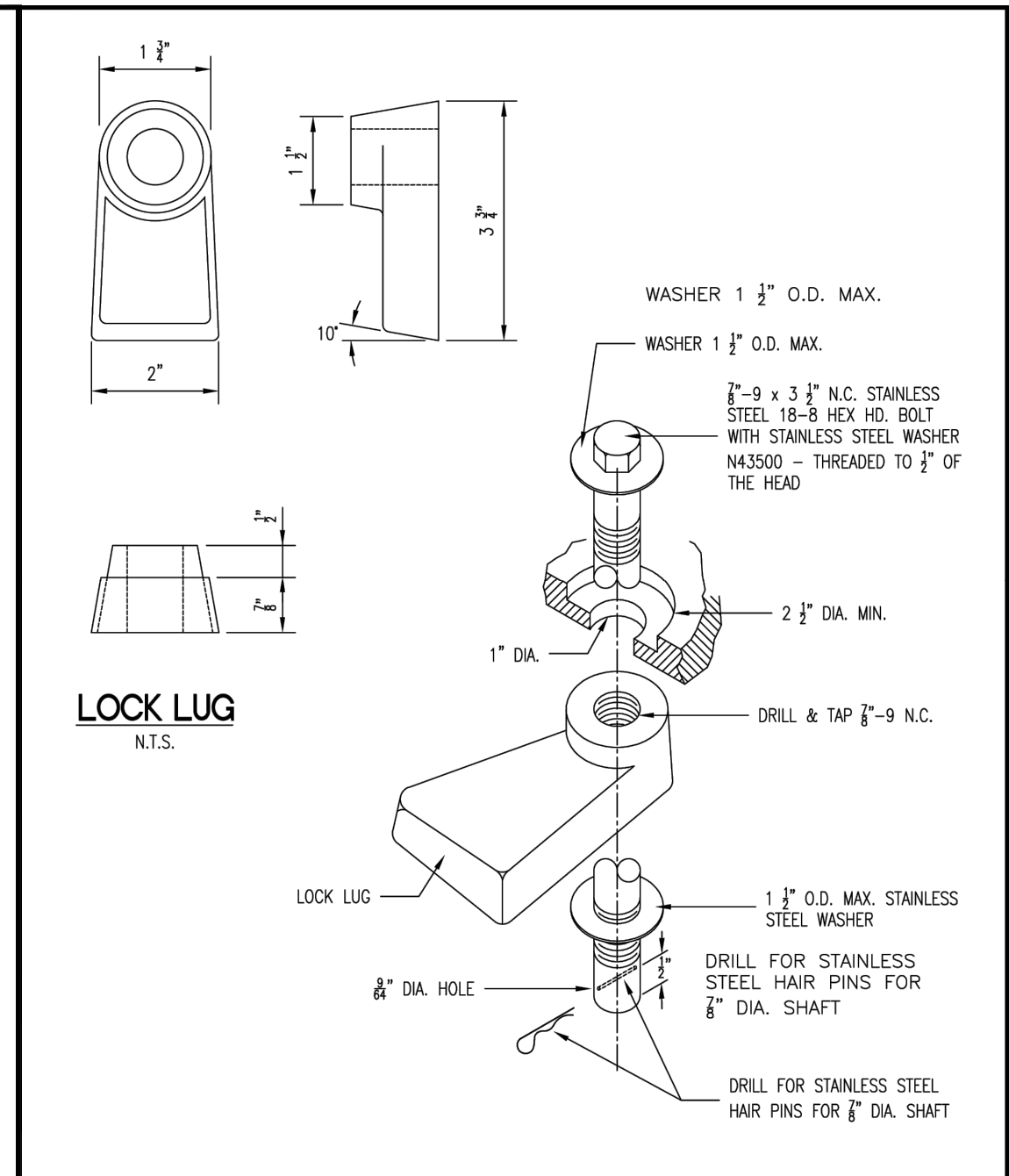

Duckett Creek Sanitary District  
LOCKING DEVICE FOR TYPE "N" LOCK TYPED MANHOLE COVER  
I LOCKING DEVICE FOR TYPE "N" LOCK TYPED MANHOLE COVER NOT TO SCALE

P.O. BOX 481 LEXINGTON, KY 40588  
(859) 785-0383  
CIVIL DESIGN, LAND SURVEYING,  
GEOLOGICAL ENGINEERING, DRILLING SERVICES,  
IBC SPECIAL INSPECTIONS, MATERIAL TESTING,  
CM-CEI-CONSTRUCTION SERVICES

**THOROUGHBREED**  
DESIGN | ENGINEER | CONSTRUCT

**UTILITY DETAILS**  
**CHRISTIAN BROTHERS AUTOMOTIVE**  
OF FALLON, ST. CHARLES COUNTY, MISSOURI 63368

PROJECT NO:	220120	DRAWN BY:	PCD
DATE:	10-24-2022	REVIEWED BY:	DJR

ISSUED FOR PERMITTING	DATE:
REV 1	11-18-2022
REV 2	1-6-2023
REV 3	1-13-2023
REV 4	02-09-23



02-09-23

REV 1 11-18-2022  
REV 2 1-6-2023  
REV 3 1-6-2023

C-6.5