

CAST IRON MANHOLE COVERS (LOCK TYPE)

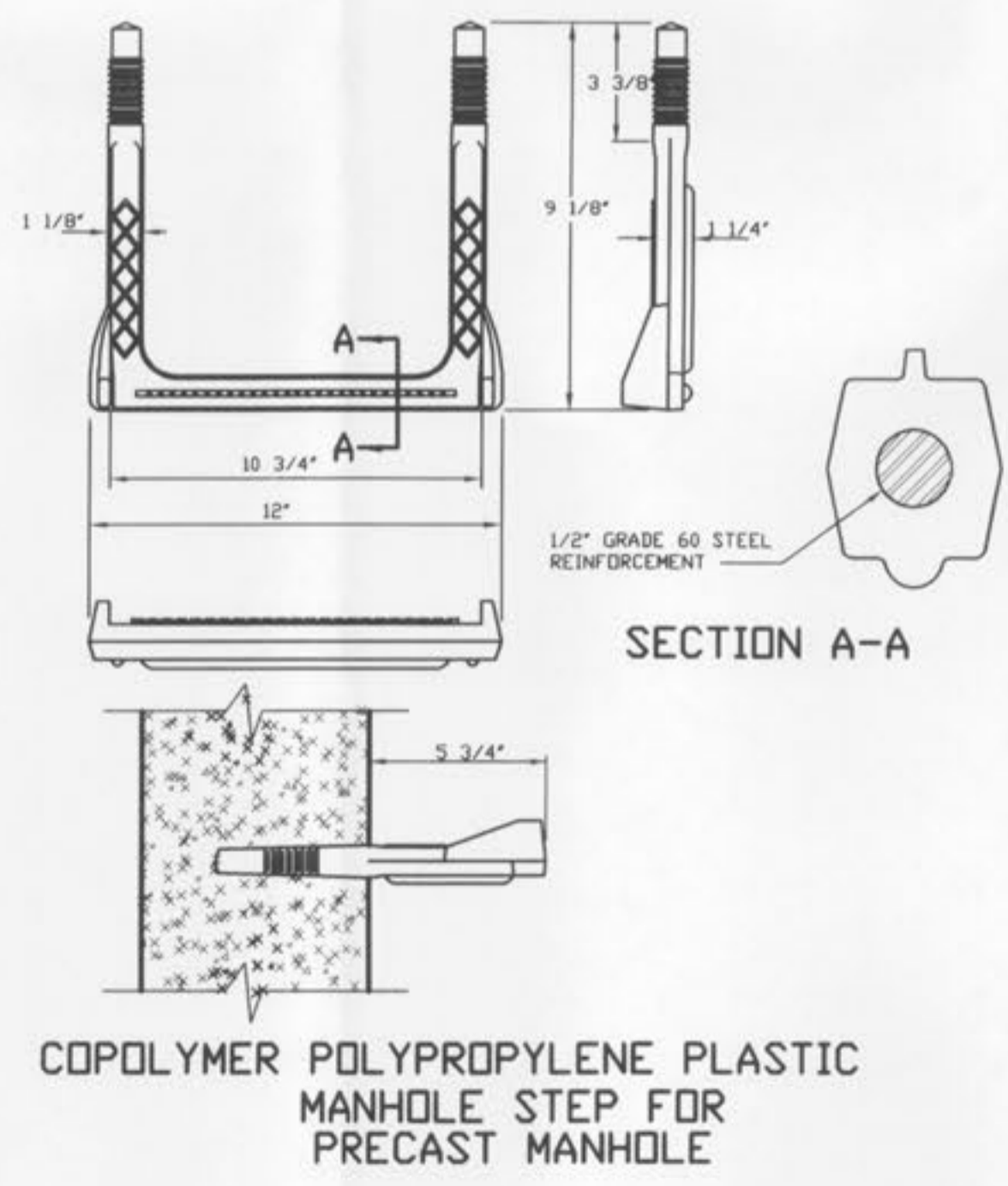
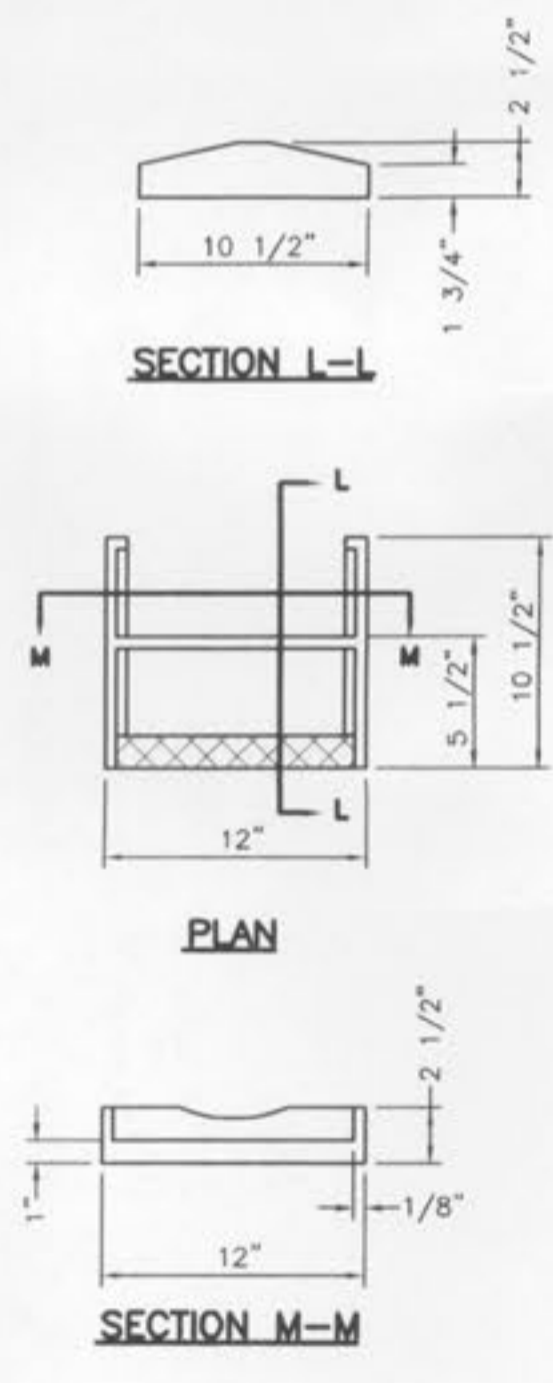
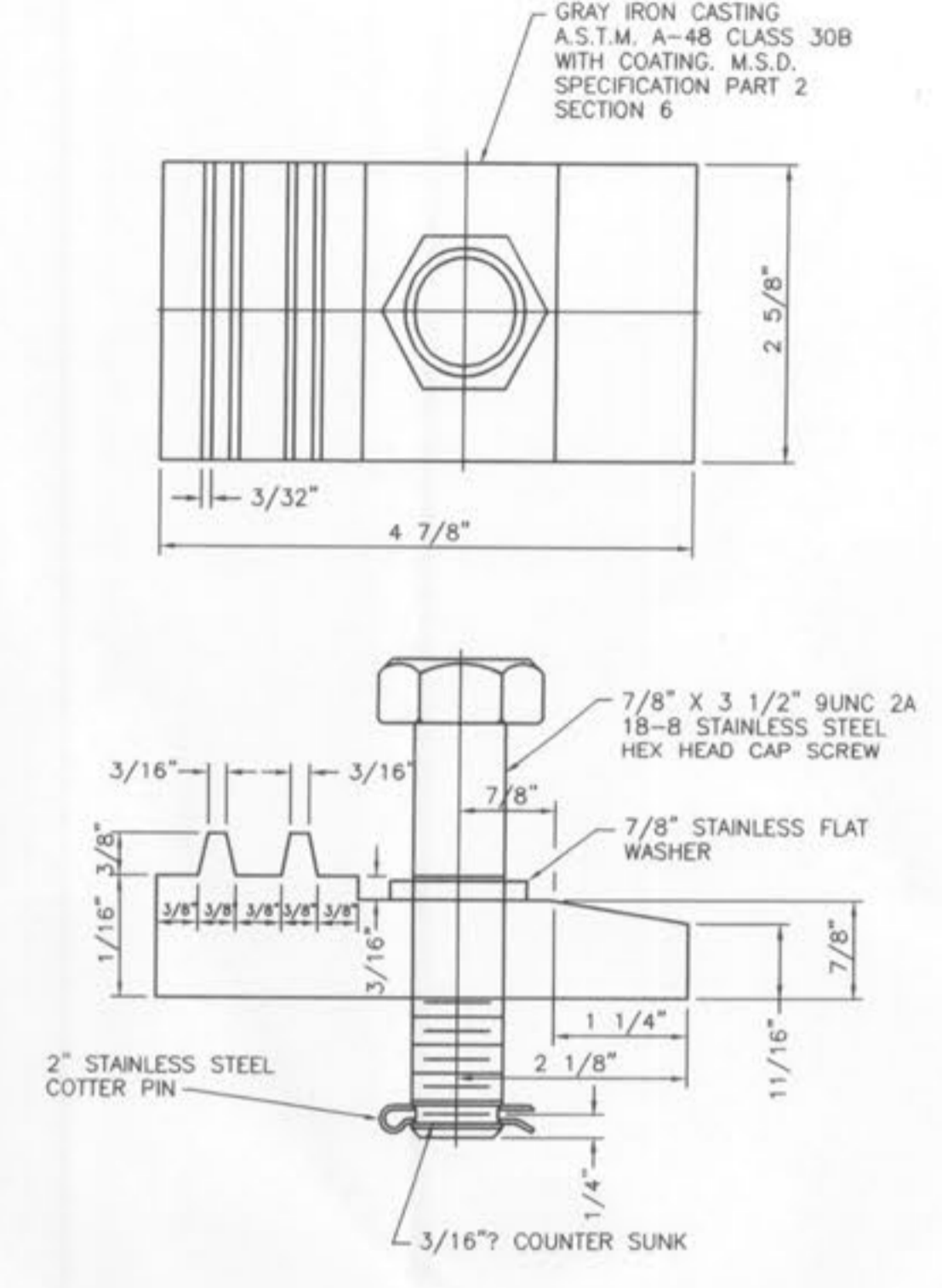
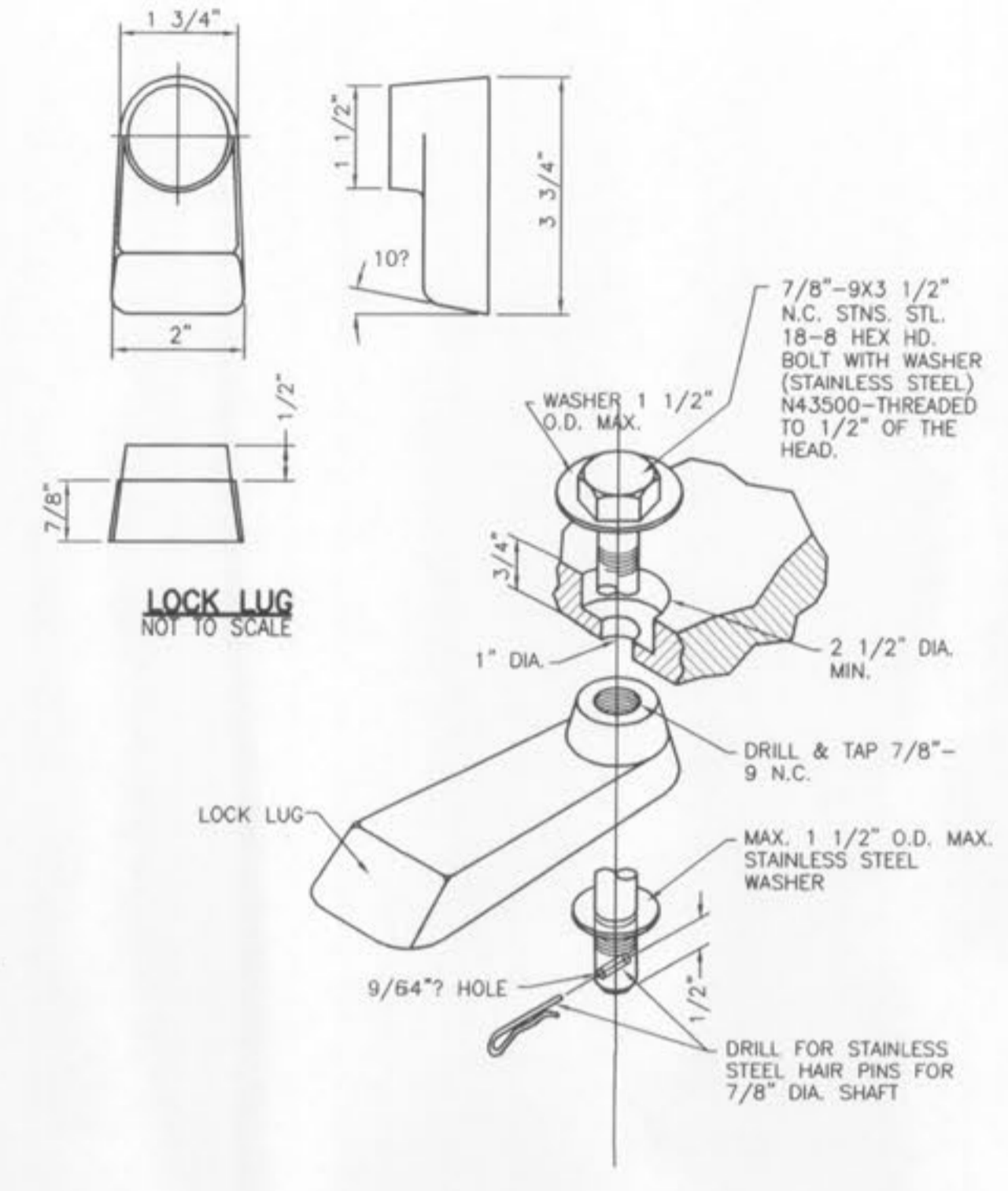
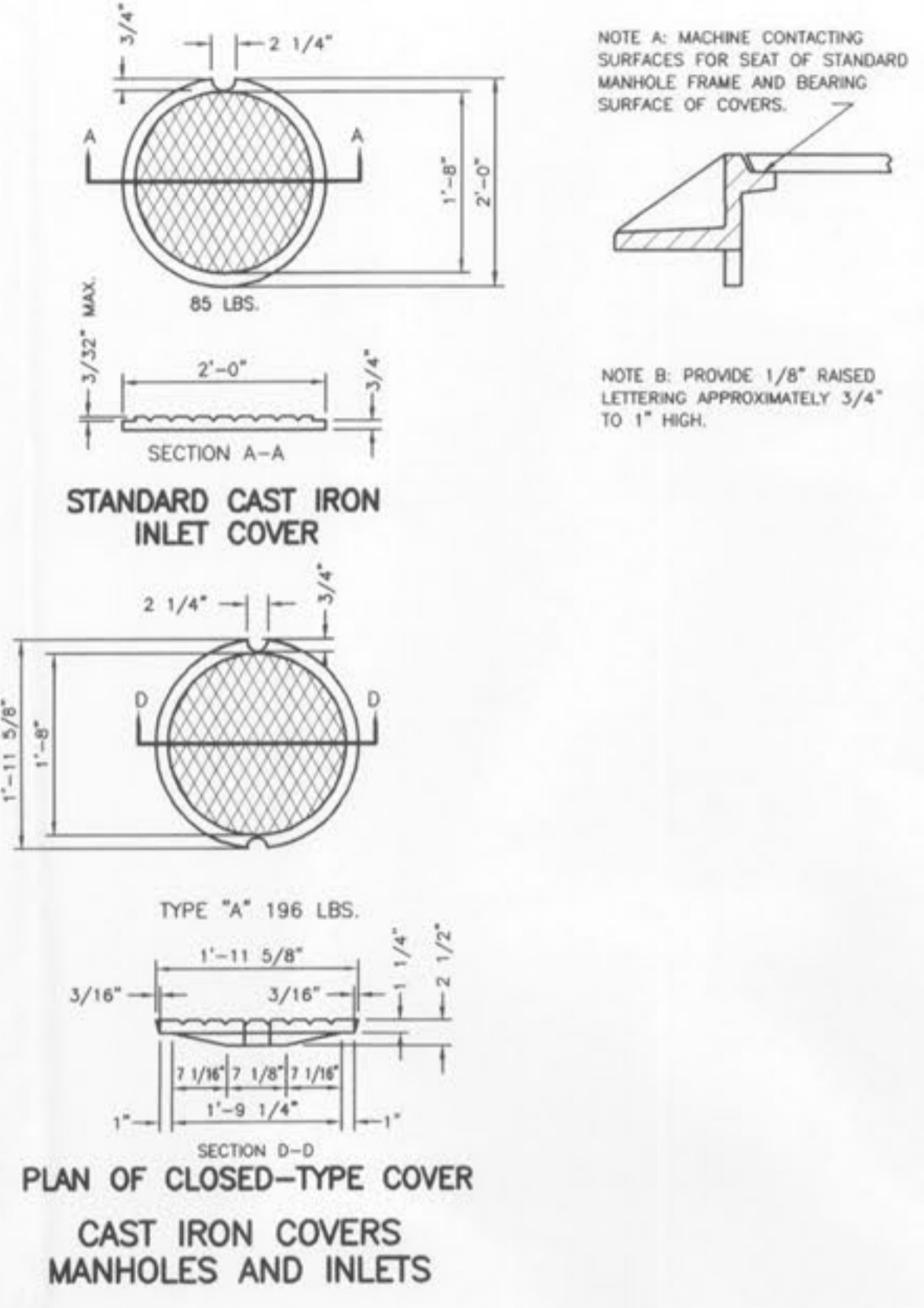

STANDARD SANITARY DETAILS

CITY OF O'FALLON  
DEPARTMENT OF PUBLIC  
WORKS DESIGN GROUP  
O'FALLON, MISSOURI

DISCLAIMER OF RESPONSIBILITY  
I HEREBY CERTIFY THAT THE DOCUMENTS WITHIN THIS SHEET AND I HEREBY DISCLAIM ANY RESPONSIBILITY FOR ALL OTHER CHANGES, OMISSIONS OR IMPROVEMENTS RELATIVE TO THE PROJECT TO BE USED FOR ANY PART OR PARTS OF THE ARCHITECTURAL OR ENGINEERING PROJECT OR DRAWING.

DESIGNED: GDD  
CHECKED: \_\_\_\_\_  
DATE: \_\_\_\_\_  
PROJECT NO.: \_\_\_\_\_

SHEET  
OF

SANITARY DETAILS FOR  
CHRISTIAN BROTHERS  
AUTOMOTIVE

ST. CHARLES ENGINEERING & SURVEYING, INC.  
801 S. FIFTH STREET, SUITE 202  
ST. CHARLES, MO. 63301  
TEL: (636) 947-0607 FAX: (636) 947-2448

S E S



ORDER NO.  
08-0643-01  
DATE  
02-20-09  
D-2