

D

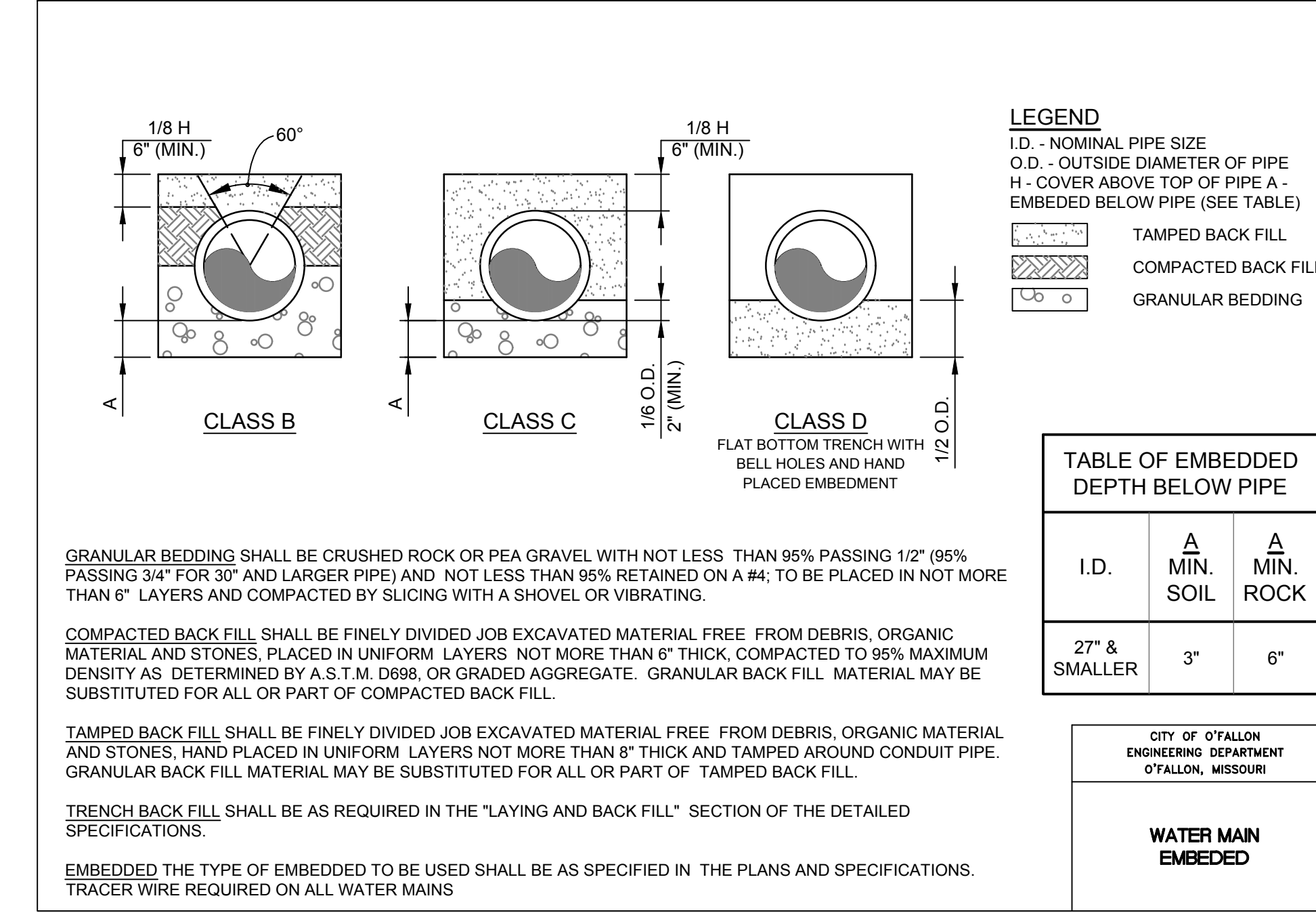

C

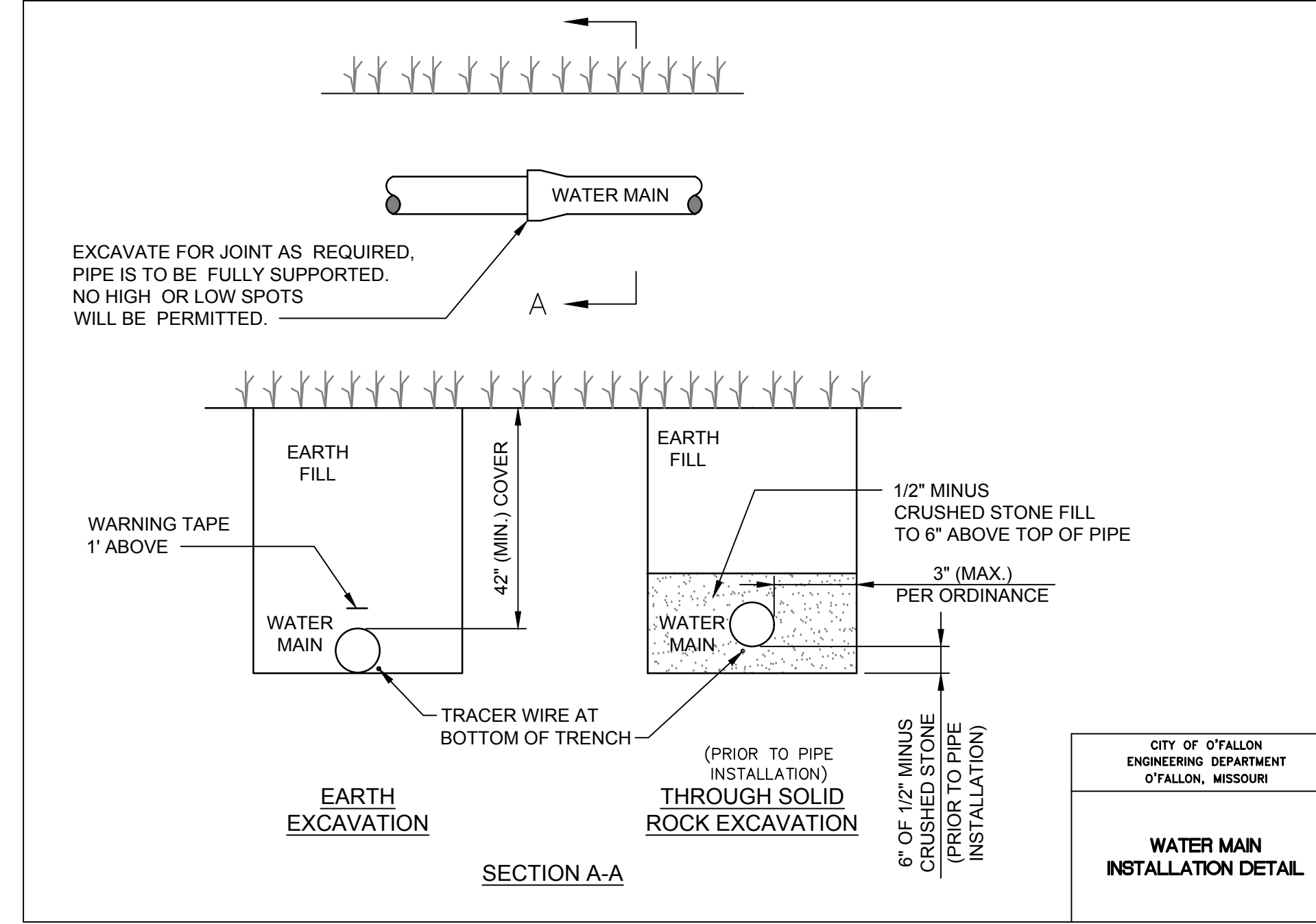
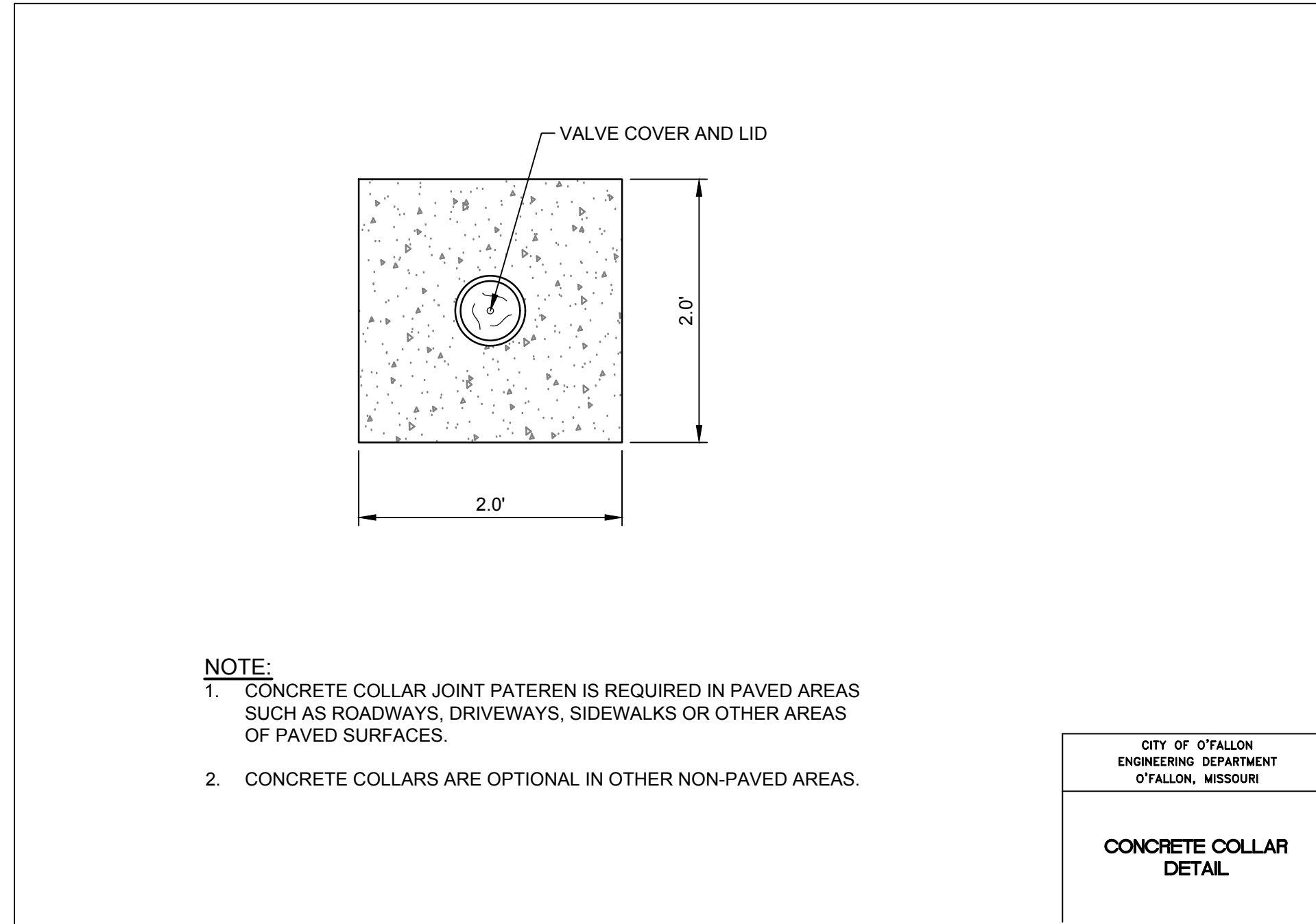
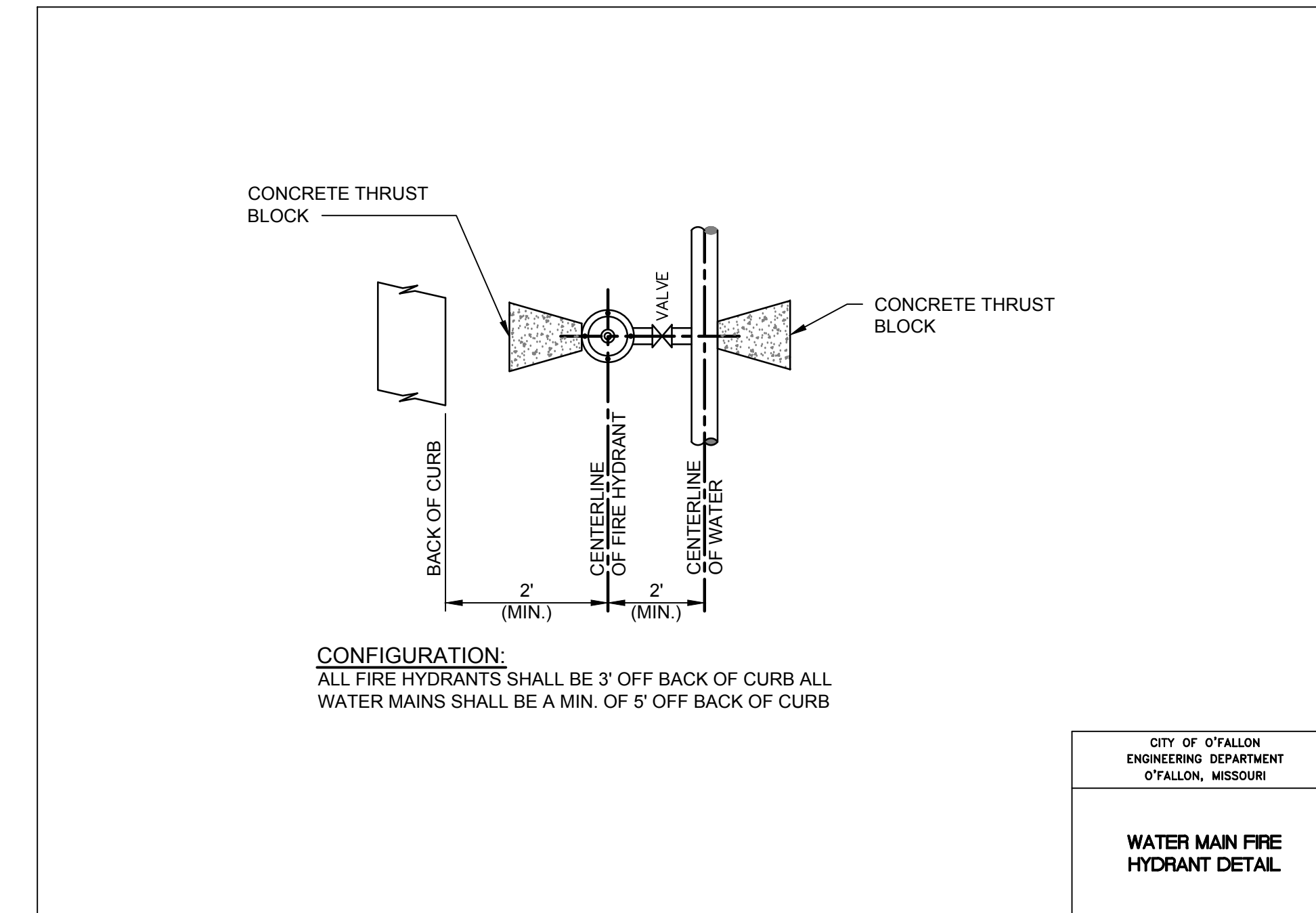
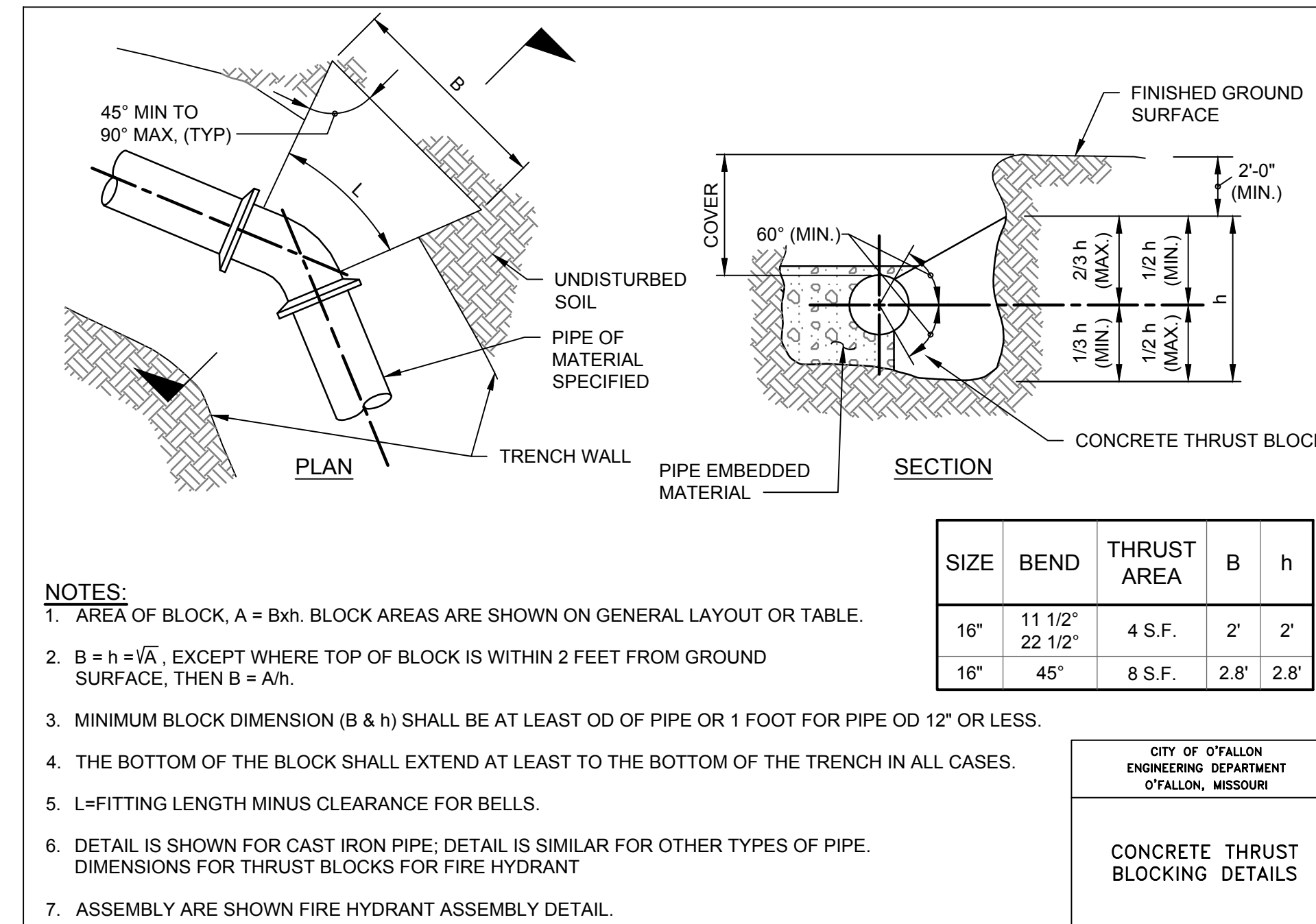
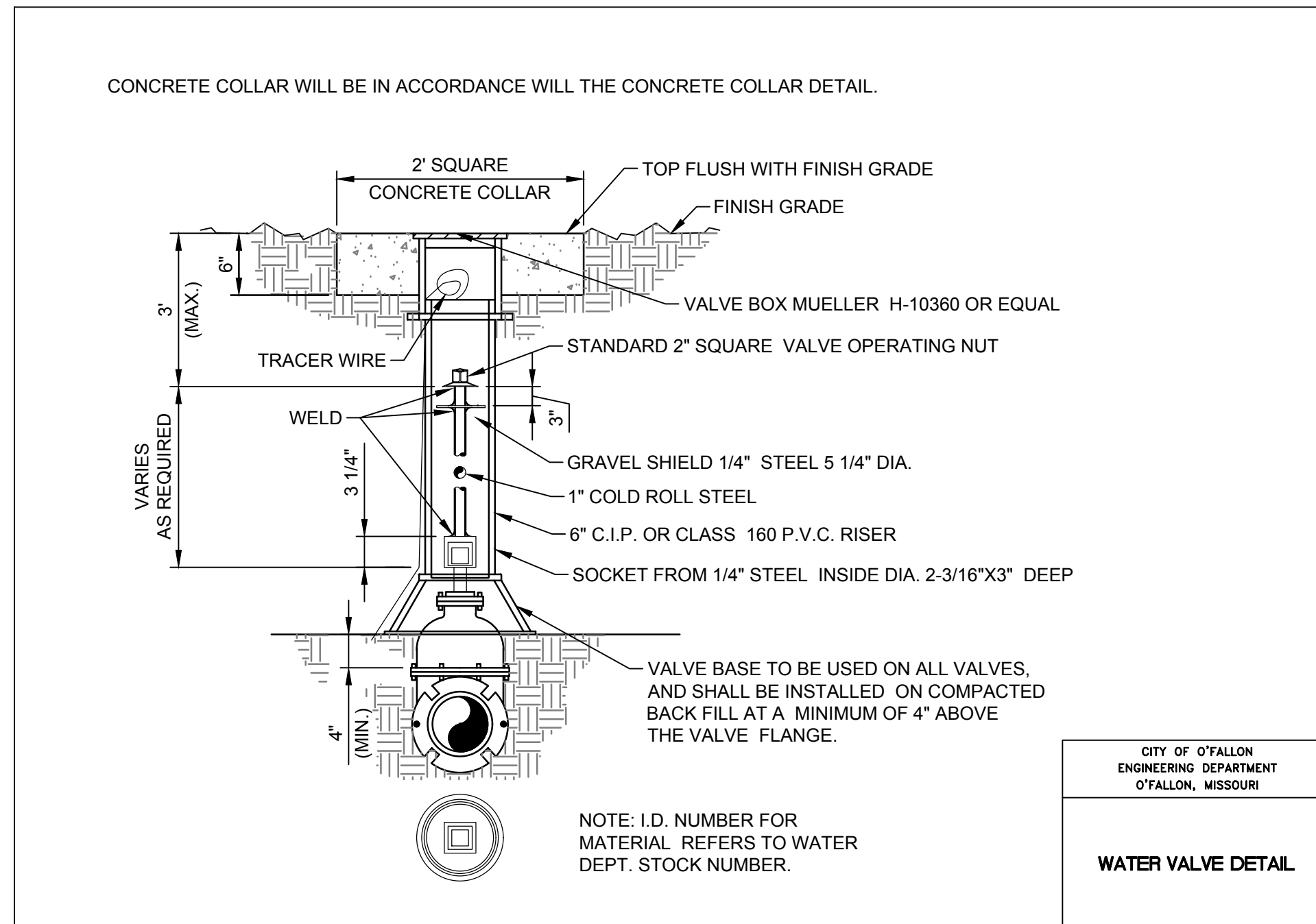

B

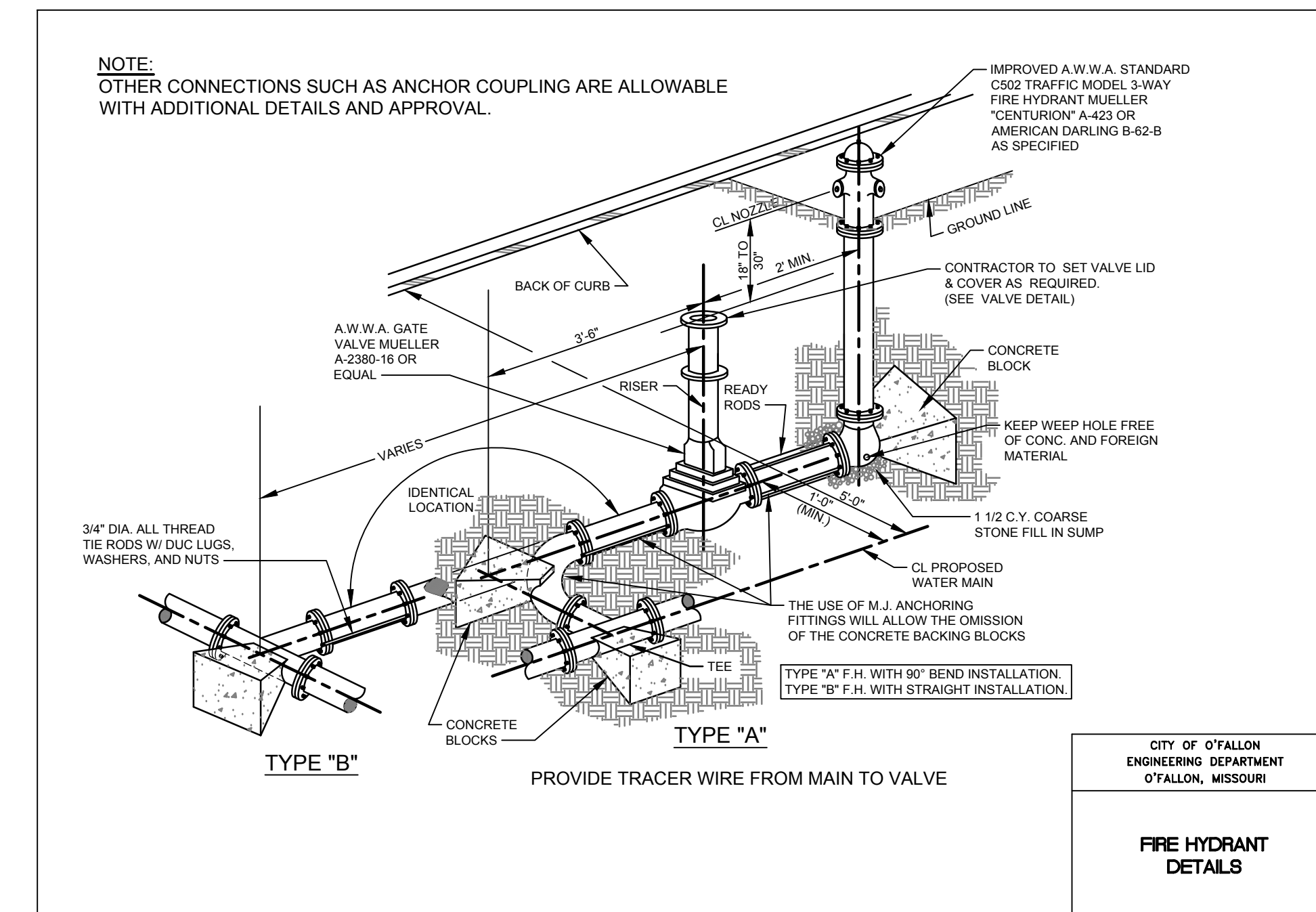
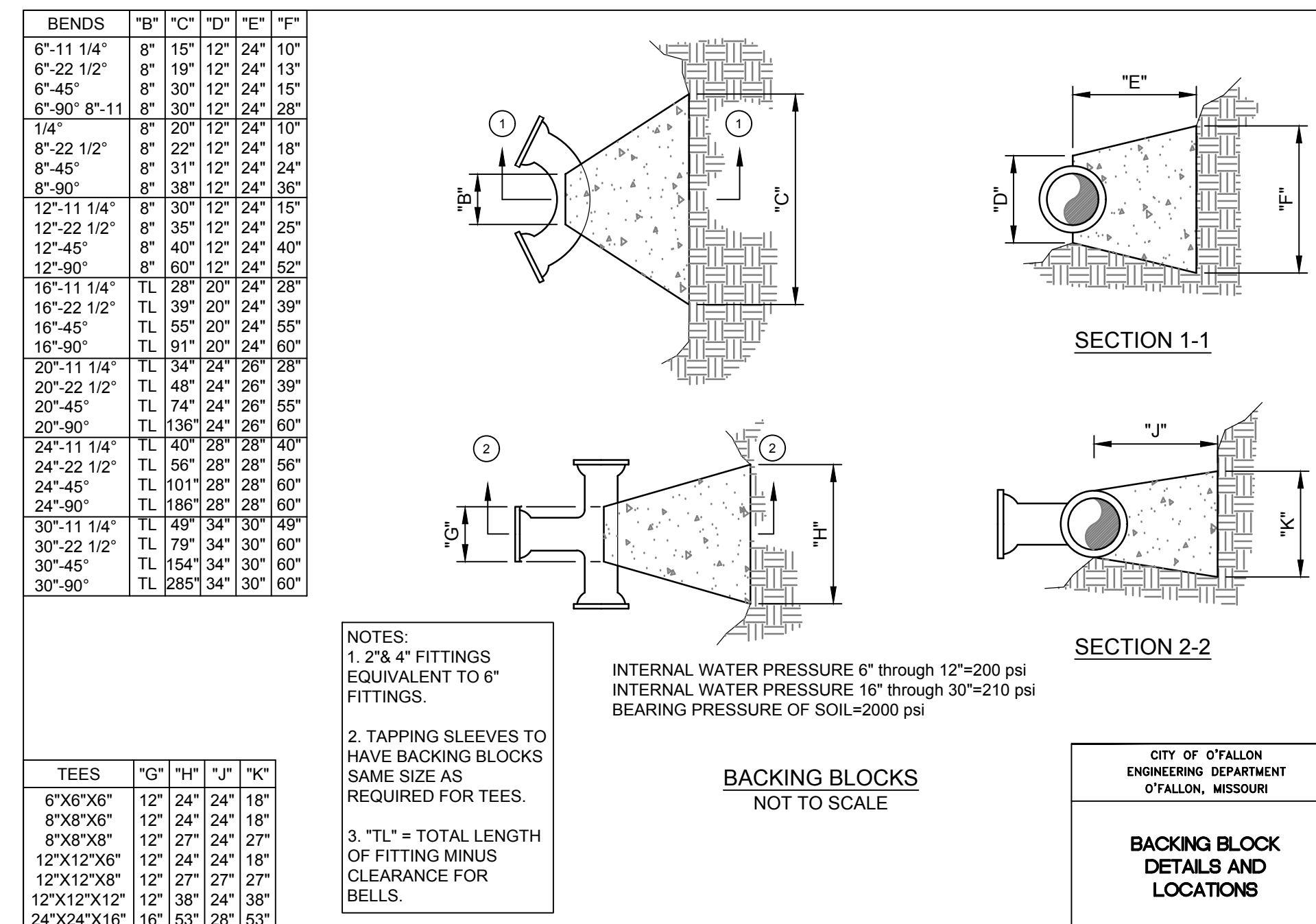
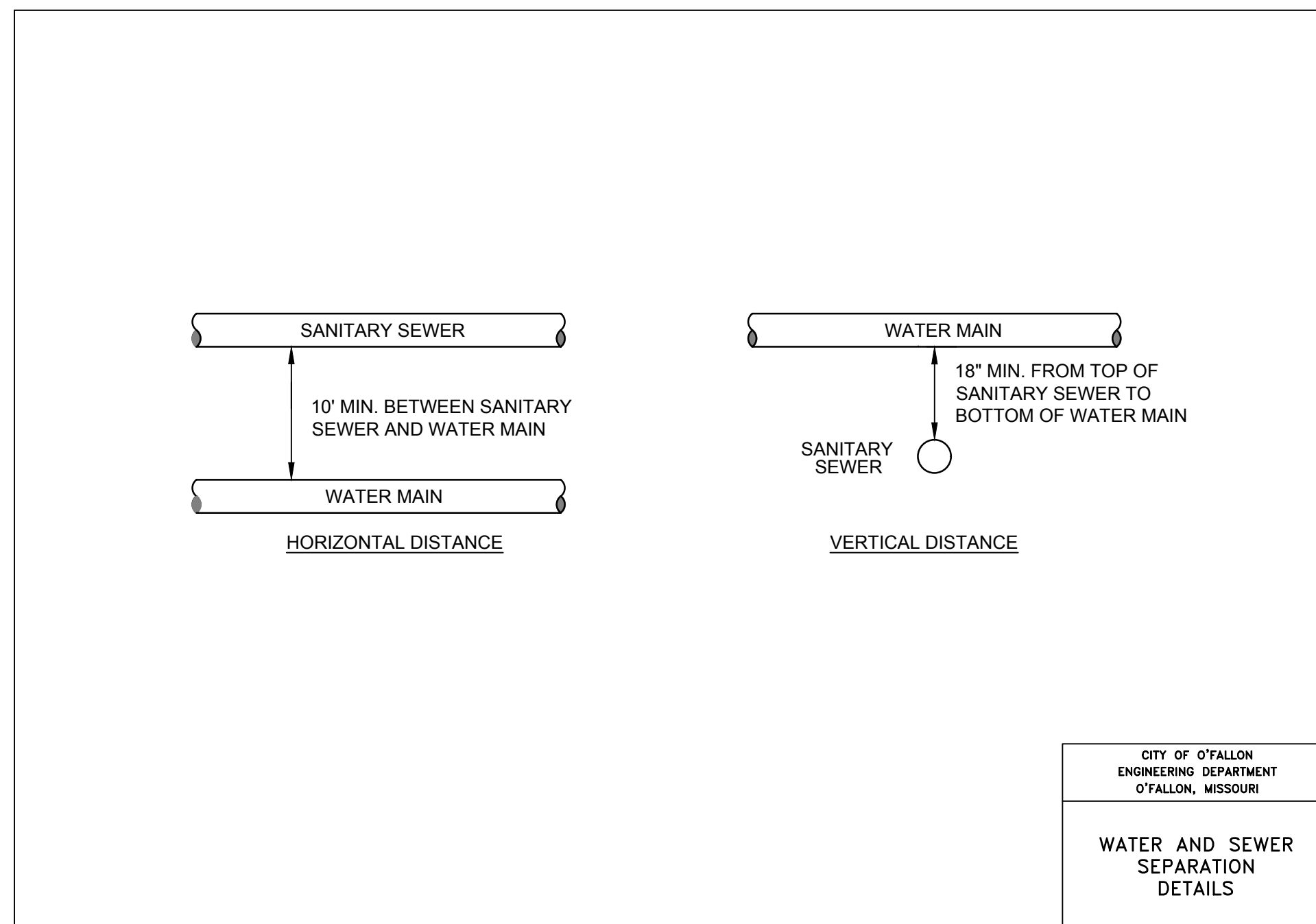

A

DUCTILE IRON PIPE INSTALLATION SHALL FOLLOW THE DUCTILE IRON RESEARCH ASSOCIATION (DIPRA) GUIDE LINE.

THE INSTALLATION OF PVC PIPE SHALL FOLLOW THE UNI-BELL PVC PIPE ASSOCIATION HANDBOOK OF PVC DESIGN AND CONSTRUCTION.

MARK	DATE	DESCRIPTION