

TYPICAL PRE-CAST MH. TEE FOR REINFORCED CONCRETE PIPE SEWERS 48" AND LARGER IN DIAMETER  
METROPOLITAN ST. LOUIS SEWER DISTRICT  
Standard Details of Sewer Construction  
Dr. W.S.H. Ch. J.C.K. 1992 SHEET 19

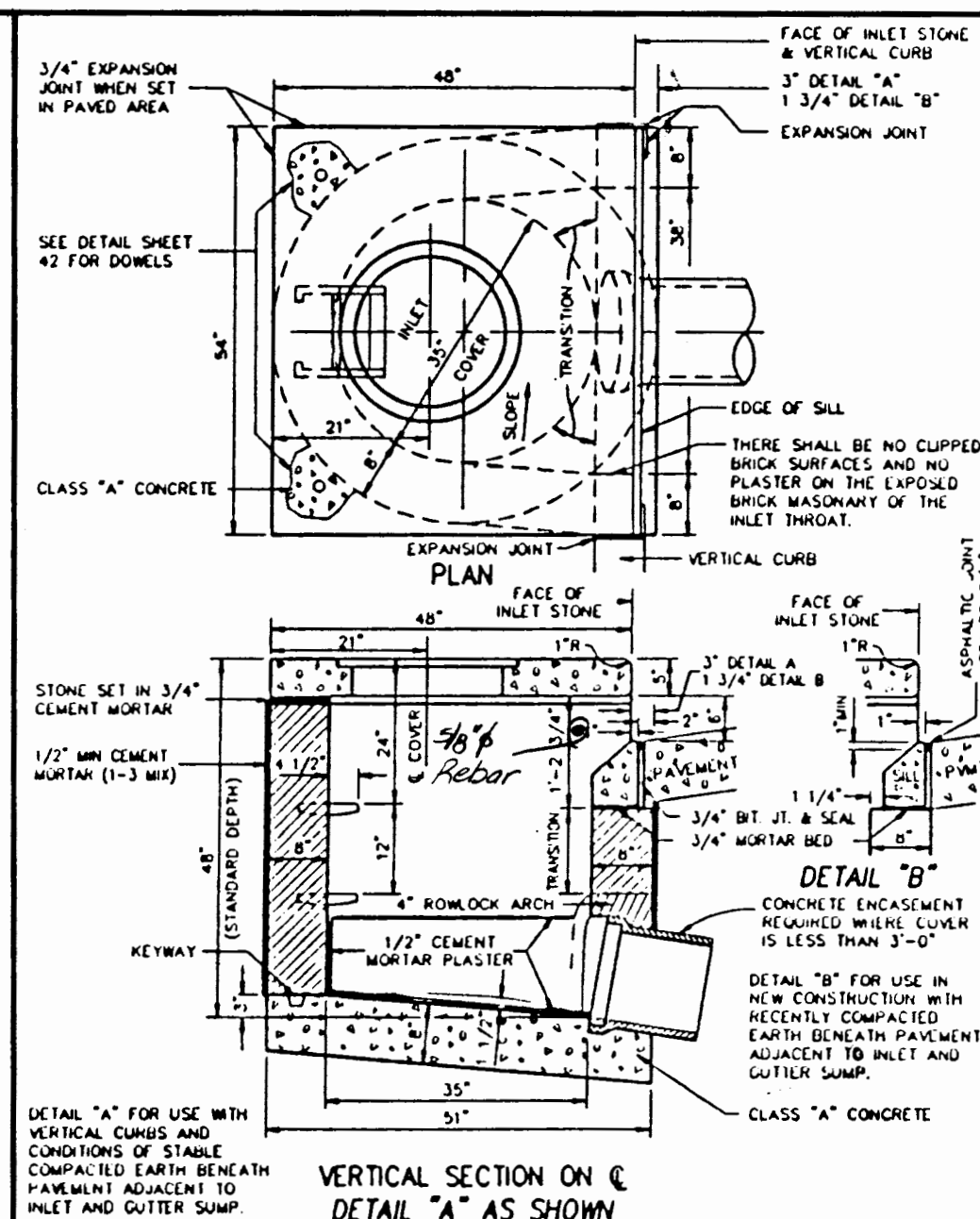

UNTRAPPED STREET INLET BRICK CONSTRUCTION  
METROPOLITAN ST. LOUIS SEWER DISTRICT  
Standard Details of Sewer Construction  
Dr. W.S.H. Ch. J.C.K. 1992 SHEET 20

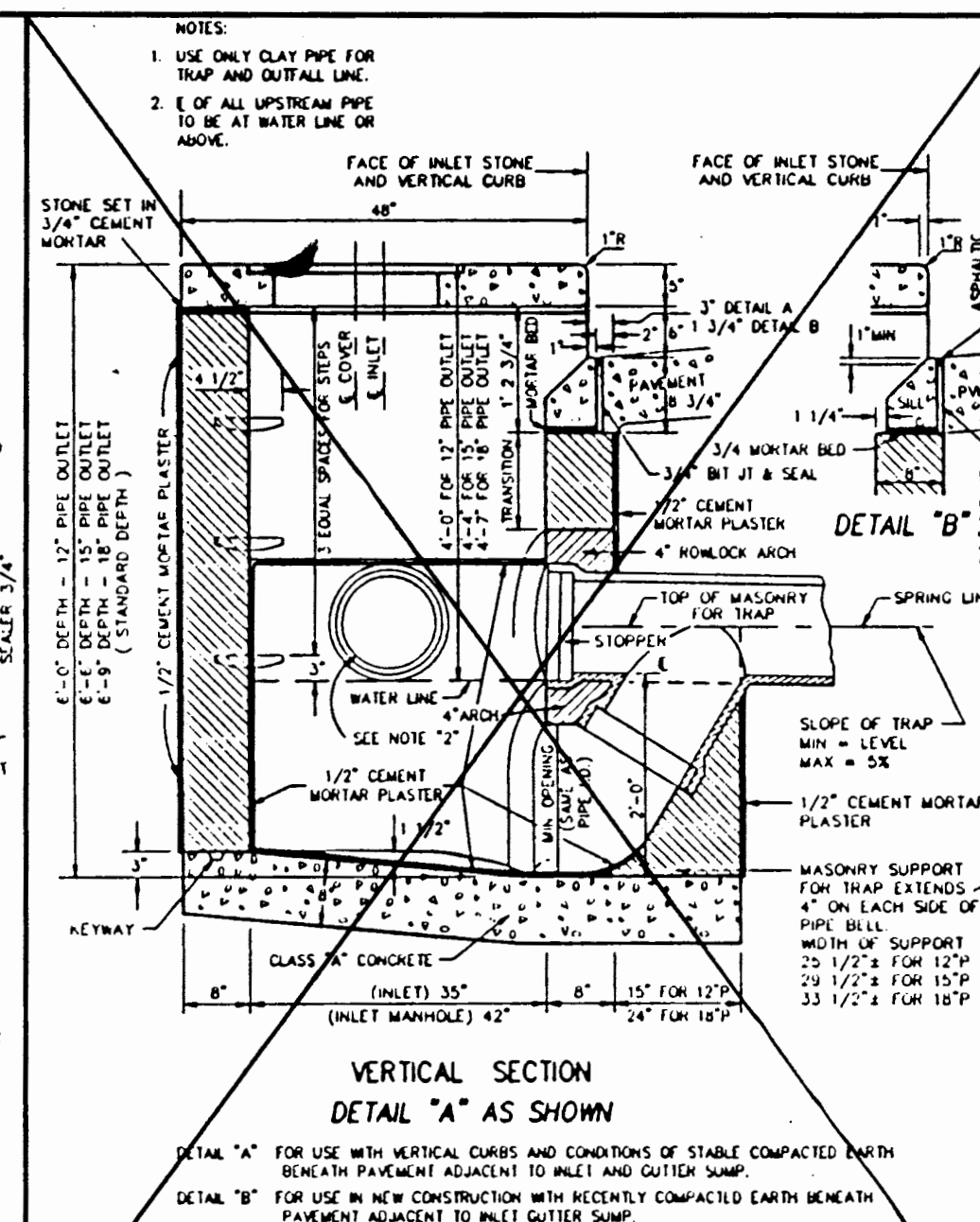

TRAPPED STREET INLET BRICK CONSTRUCTION  
METROPOLITAN ST. LOUIS SEWER DISTRICT  
Standard Details of Sewer Construction  
Dr. W.S.H. Ch. J.C.K. 1992 SHEET 21

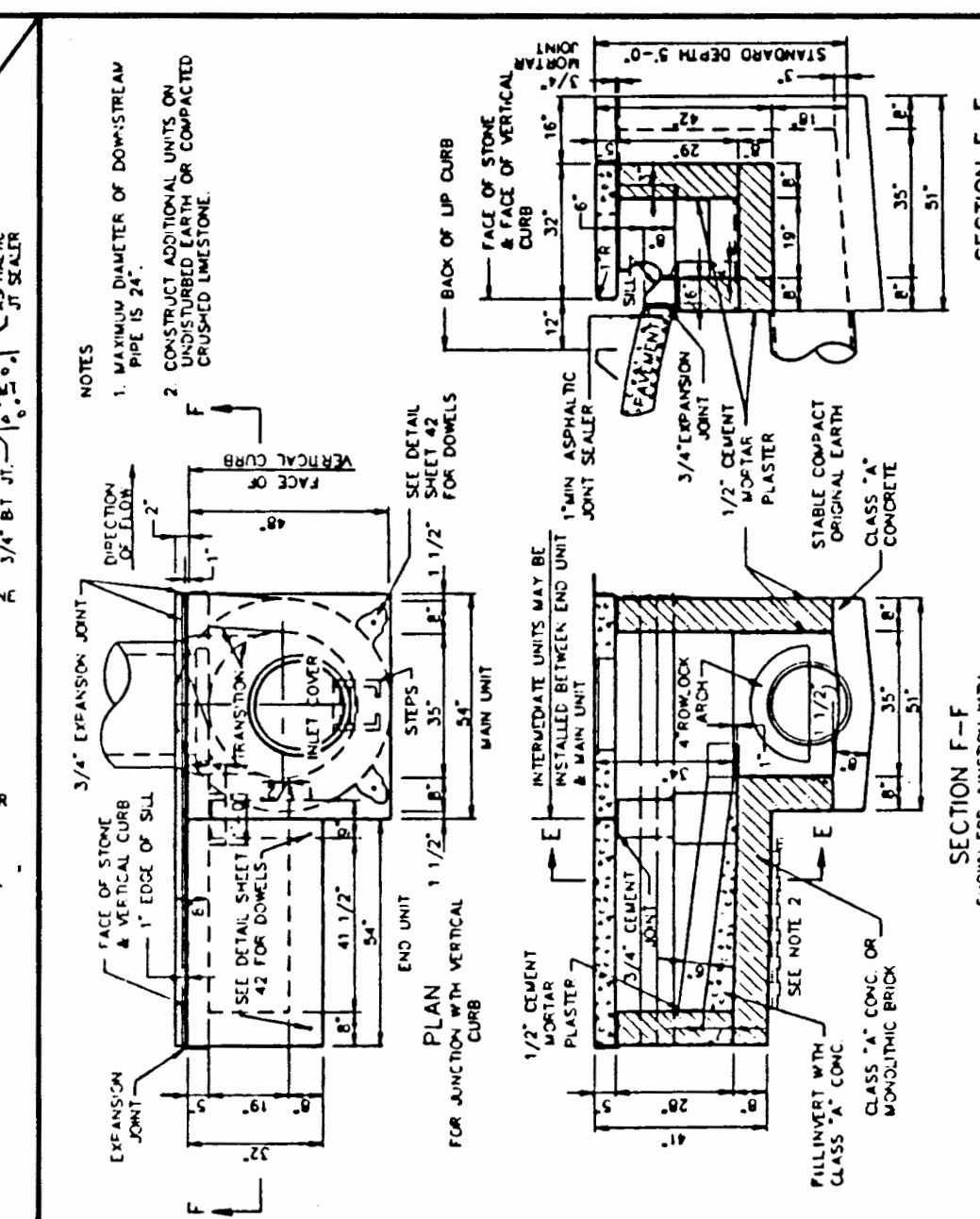

MULTIPLE STREET INLET BRICK CONSTRUCTION  
METROPOLITAN ST. LOUIS SEWER DISTRICT  
Standard Details of Sewer Construction  
Dr. D.A.B. Ch. J.C.K. 1992 SHEET 22

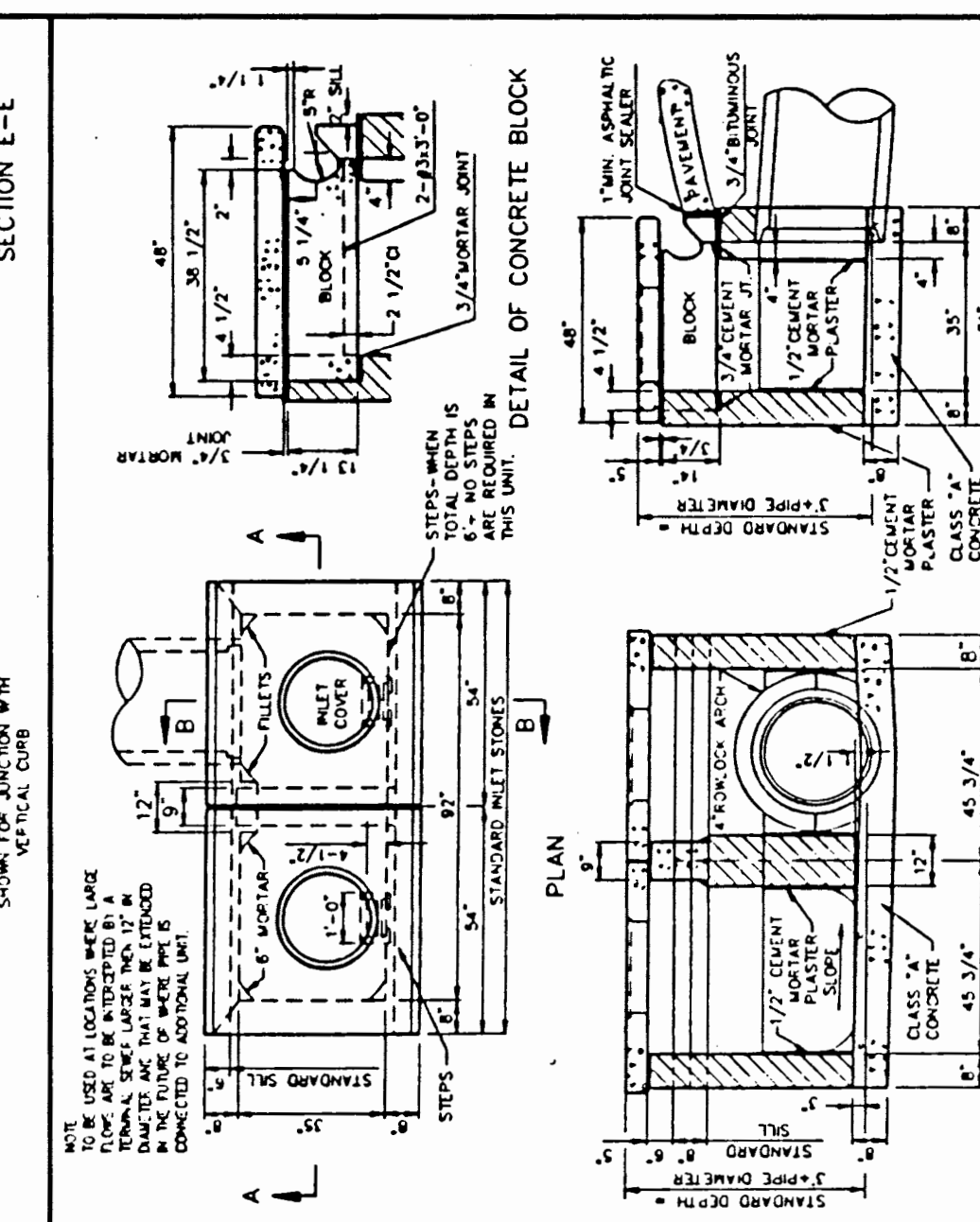

DOUBLE UNTRAPPED STREET INLET BRICK CONSTRUCTION  
METROPOLITAN ST. LOUIS SEWER DISTRICT  
Standard Details of Sewer Construction  
Dr. D.A.B. Ch. J.C.K. 1992 SHEET 23

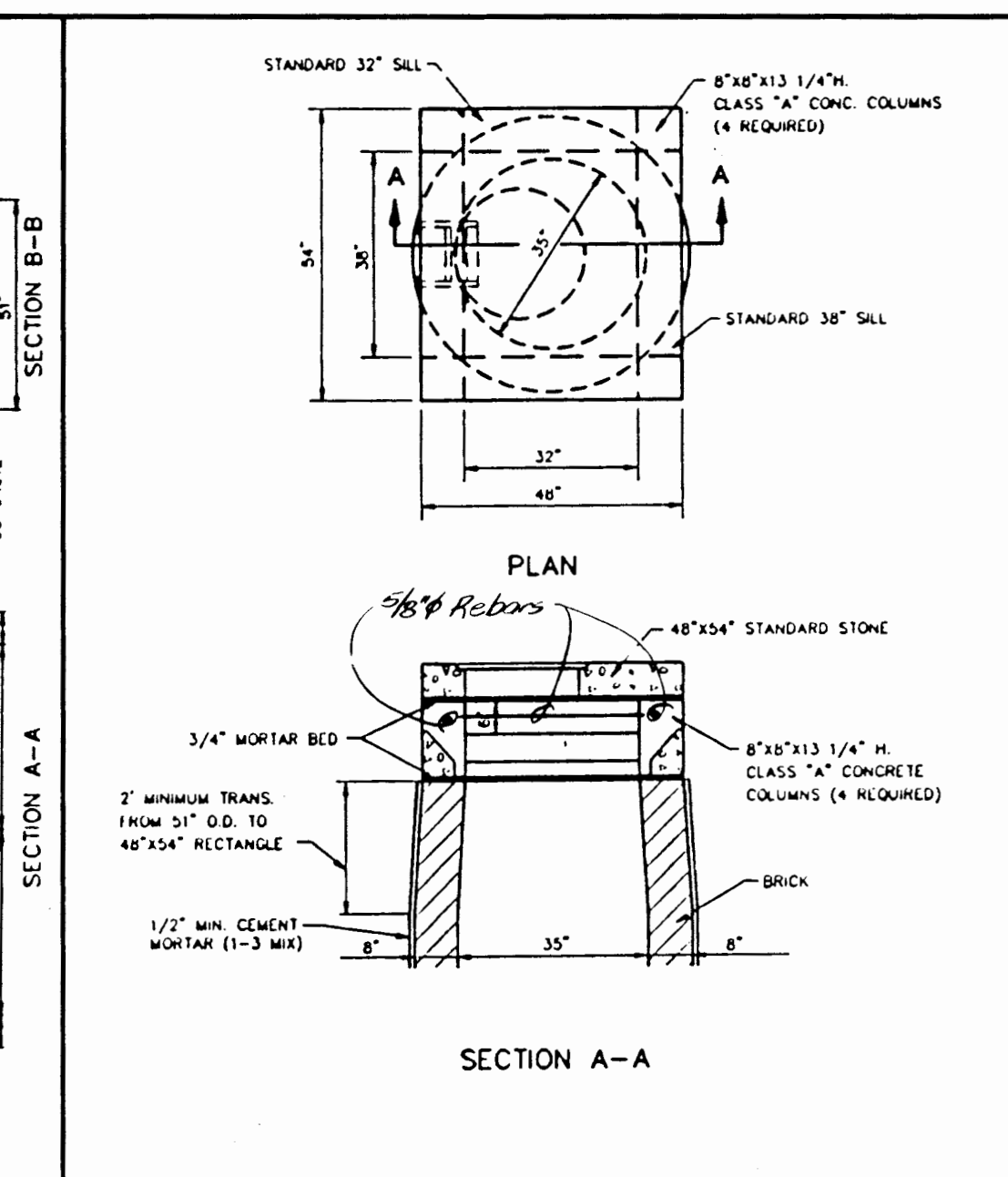

AREA INLET OPEN 4 SIDES BRICK CONSTRUCTION  
METROPOLITAN ST. LOUIS SEWER DISTRICT  
Standard Details of Sewer Construction  
Dr. R.G.W. Ch. J.C.K. 1992 SHEET 24

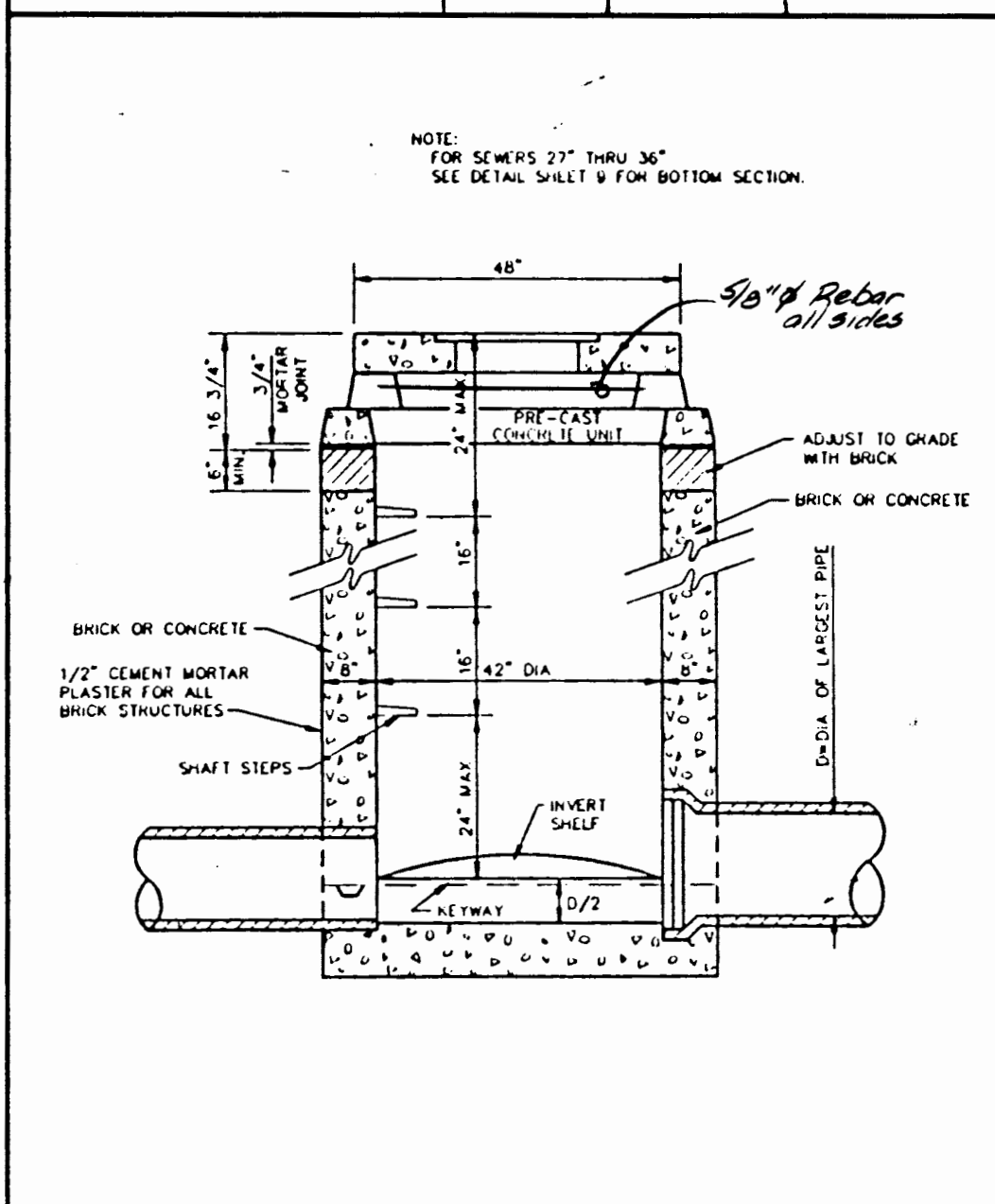

AREA INLET MANHOLE (12" THRU 24")  
METROPOLITAN ST. LOUIS SEWER DISTRICT  
Standard Details of Sewer Construction  
Dr. R.G.W. Ch. J.C.K. 1992 SHEET 25

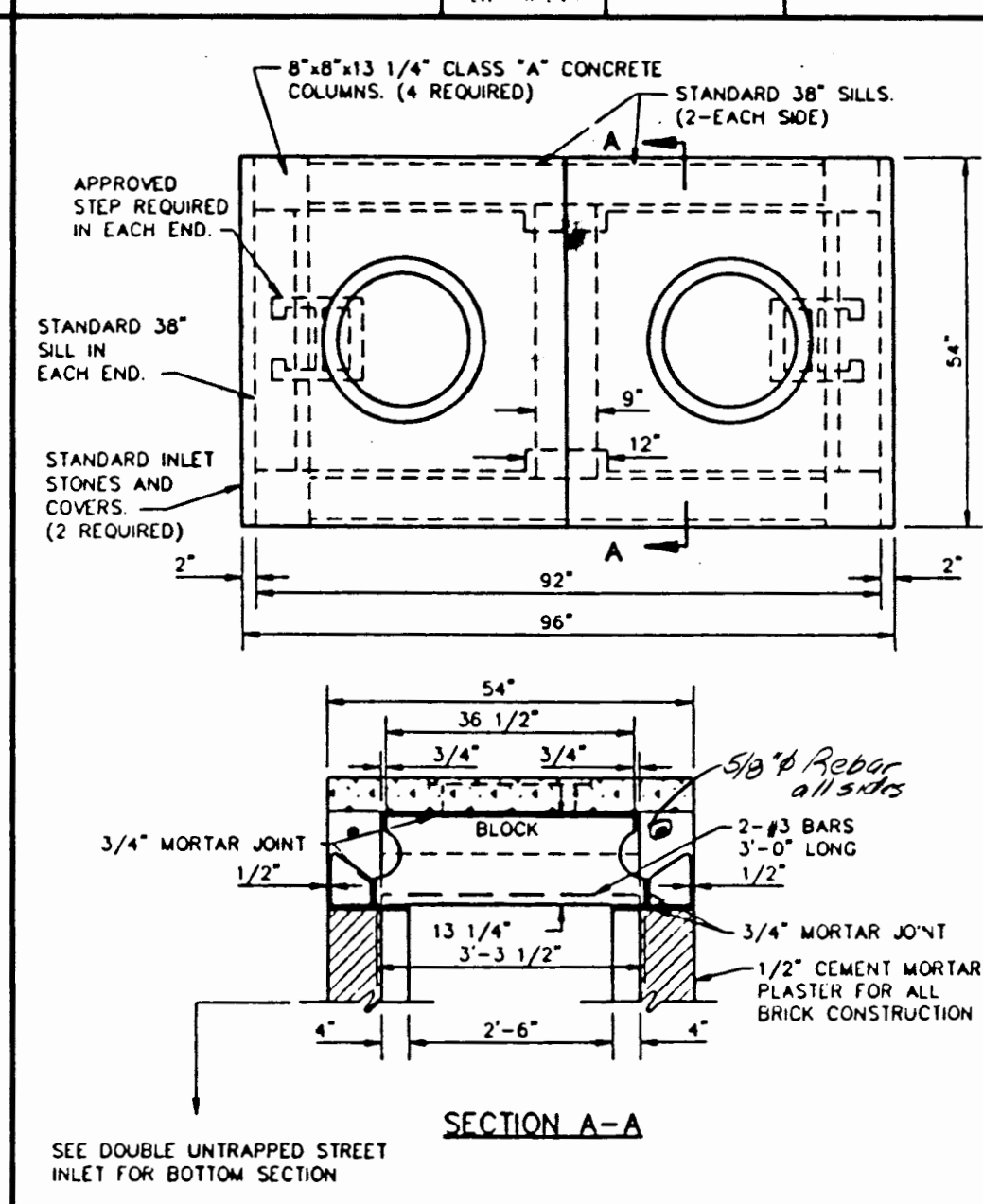

DOUBLE AREA INLET OPEN 4 SIDES BRICK CONSTRUCTION  
METROPOLITAN ST. LOUIS SEWER DISTRICT  
Standard Details of Sewer Construction  
Dr. R.G.W. Ch. J.C.K. 1992 SHEET 26

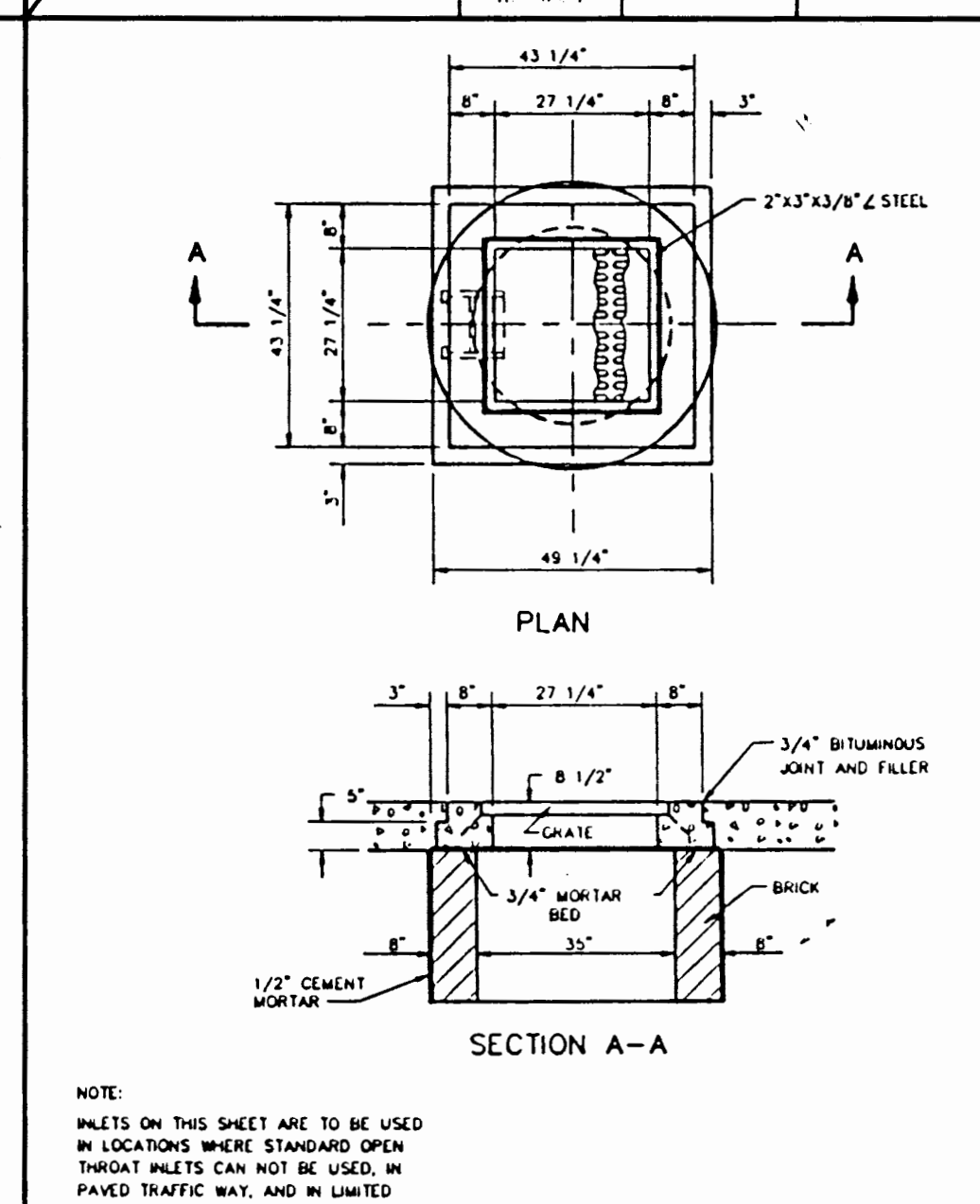

2 GRATE INLET BRICK CONSTRUCTION  
METROPOLITAN ST. LOUIS SEWER DISTRICT  
Standard Details of Sewer Construction  
Dr. R.G.W. Ch. J.C.K. 1992 SHEET 27

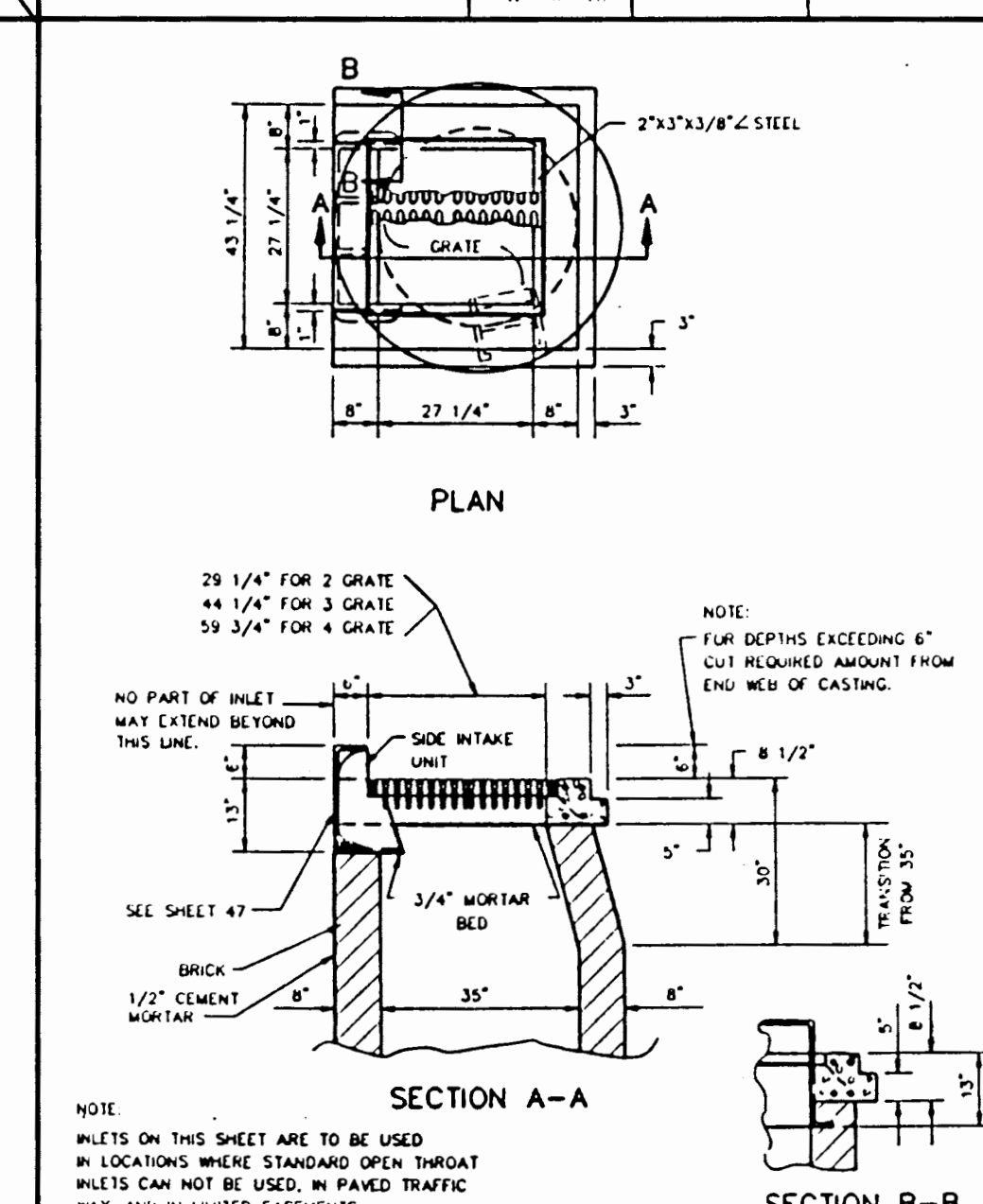

2 GRATE INLET WITH SIDE INTAKE BRICK CONSTRUCTION  
METROPOLITAN ST. LOUIS SEWER DISTRICT  
Standard Details of Sewer Construction  
Dr. R.G.W. Ch. J.C.K. 1992 SHEET 28

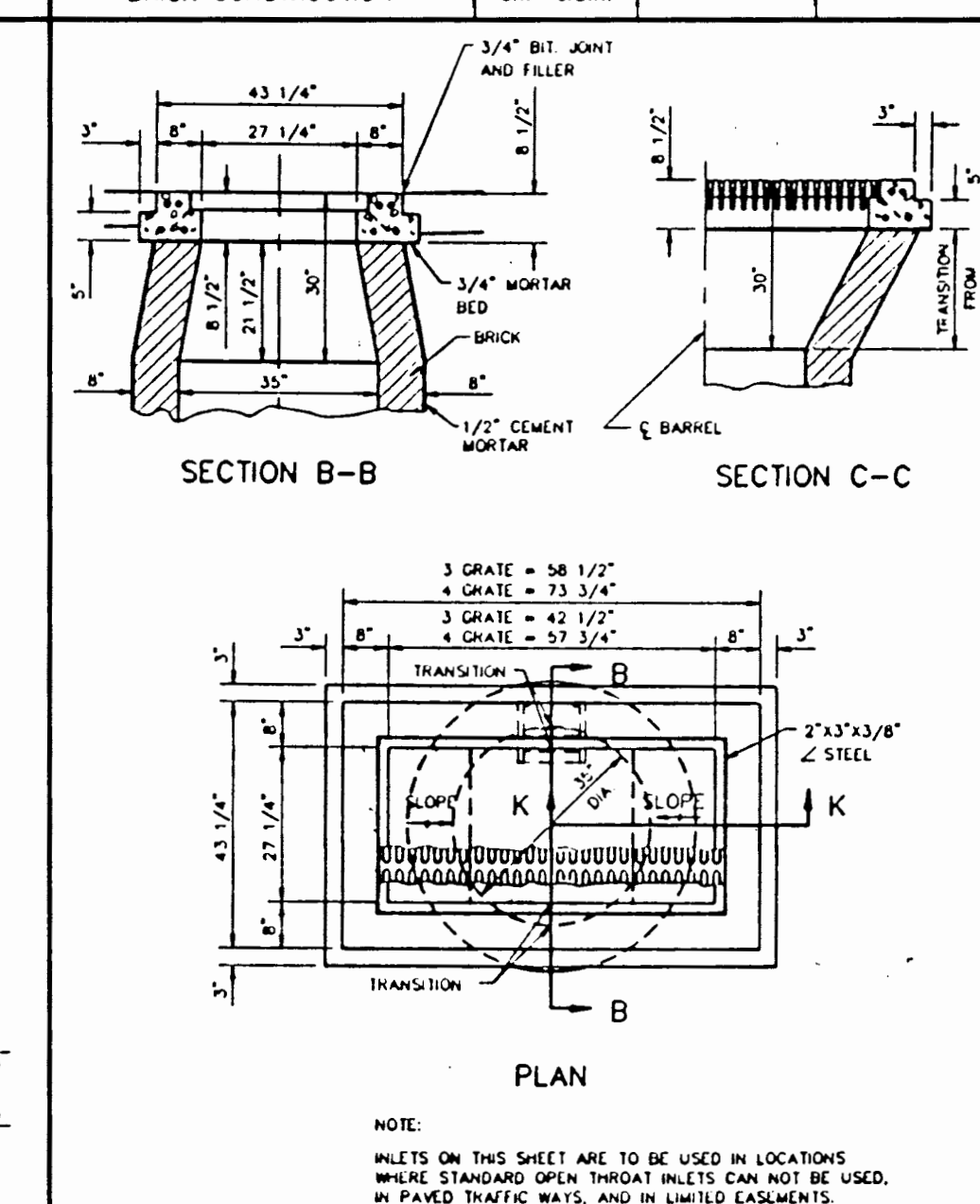

3 & 4 GRATE INLET BRICK CONSTRUCTION  
METROPOLITAN ST. LOUIS SEWER DISTRICT  
Standard Details of Sewer Construction  
Dr. R.G.W. Ch. J.C.K. 1992 SHEET 29

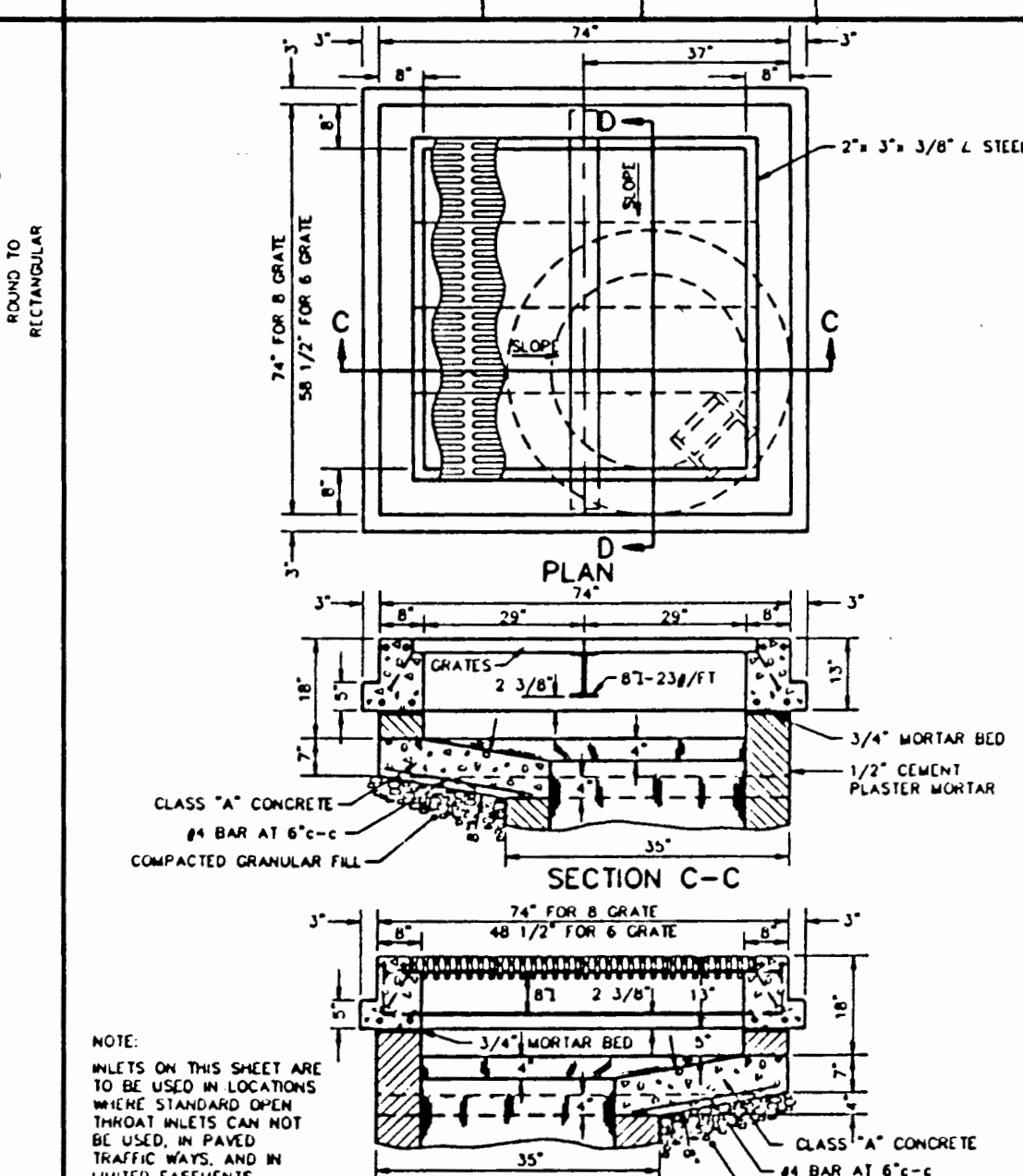

6 & 8 GRATE INLET BRICK CONSTRUCTION  
METROPOLITAN ST. LOUIS SEWER DISTRICT  
Standard Details of Sewer Construction  
Dr. W.S.H. Ch. J.C.K. 1992 SHEET 30

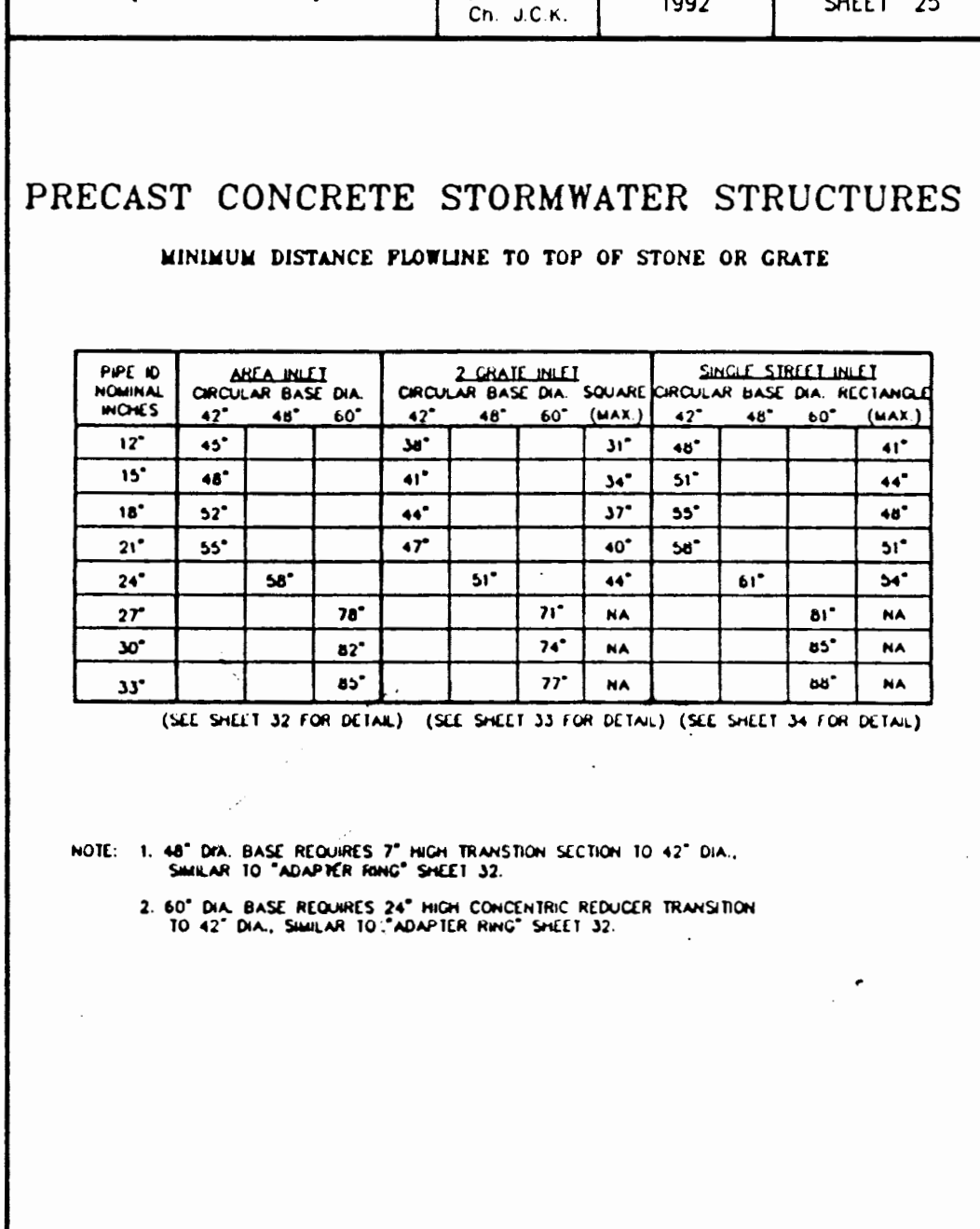

PRECAST CONCRETE STORMWATER STRUCTURES  
METROPOLITAN ST. LOUIS SEWER DISTRICT  
Standard Details of Sewer Construction  
Dr. J.L.C. Ch. J.C.K. SEPT. 1990 SHEET 31

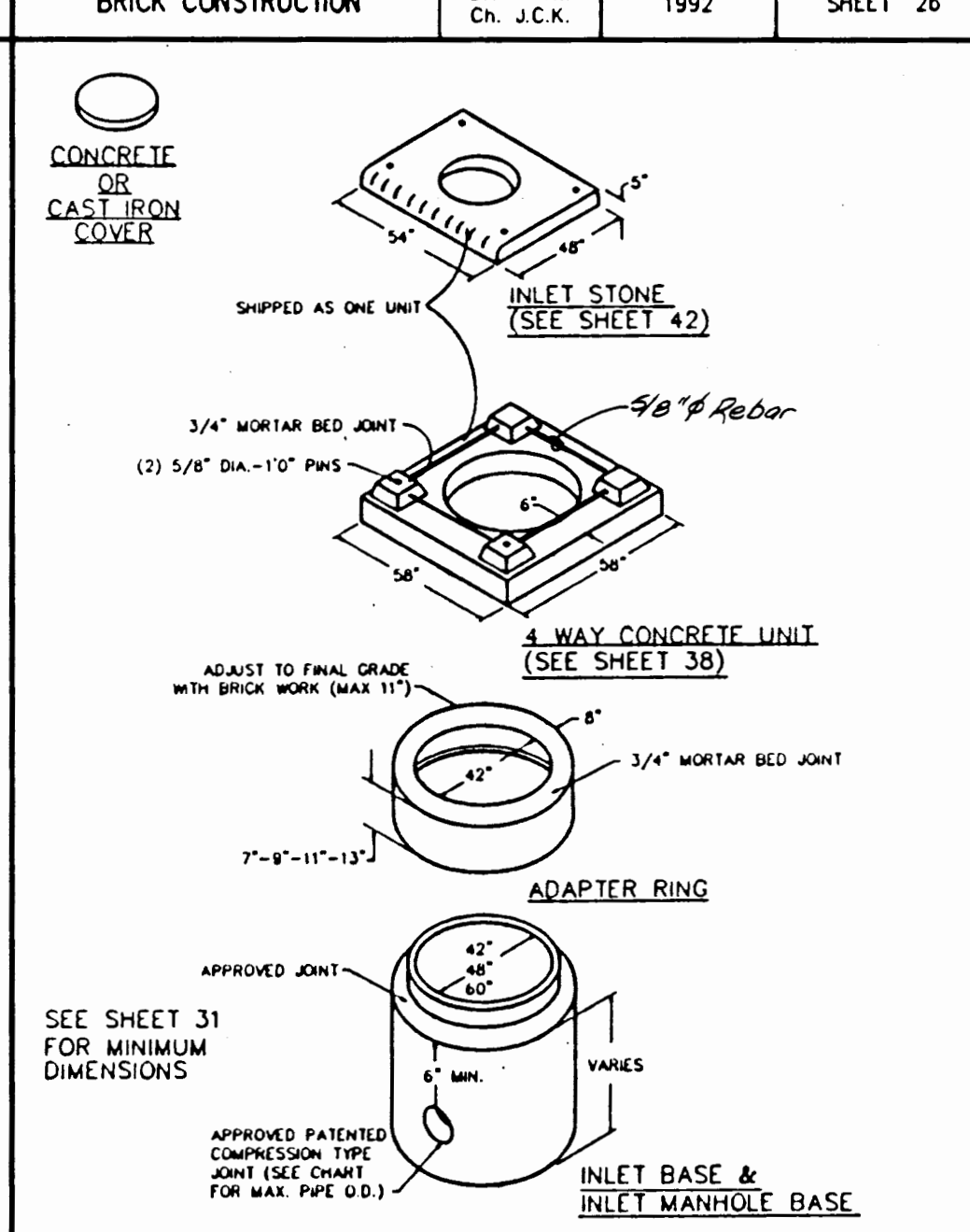

AREA INLET PRECAST CONCRETE  
METROPOLITAN ST. LOUIS SEWER DISTRICT  
Standard Details of Sewer Construction  
Dr. J.L.C. Ch. J.C.K. APRIL 1992 SHEET 32

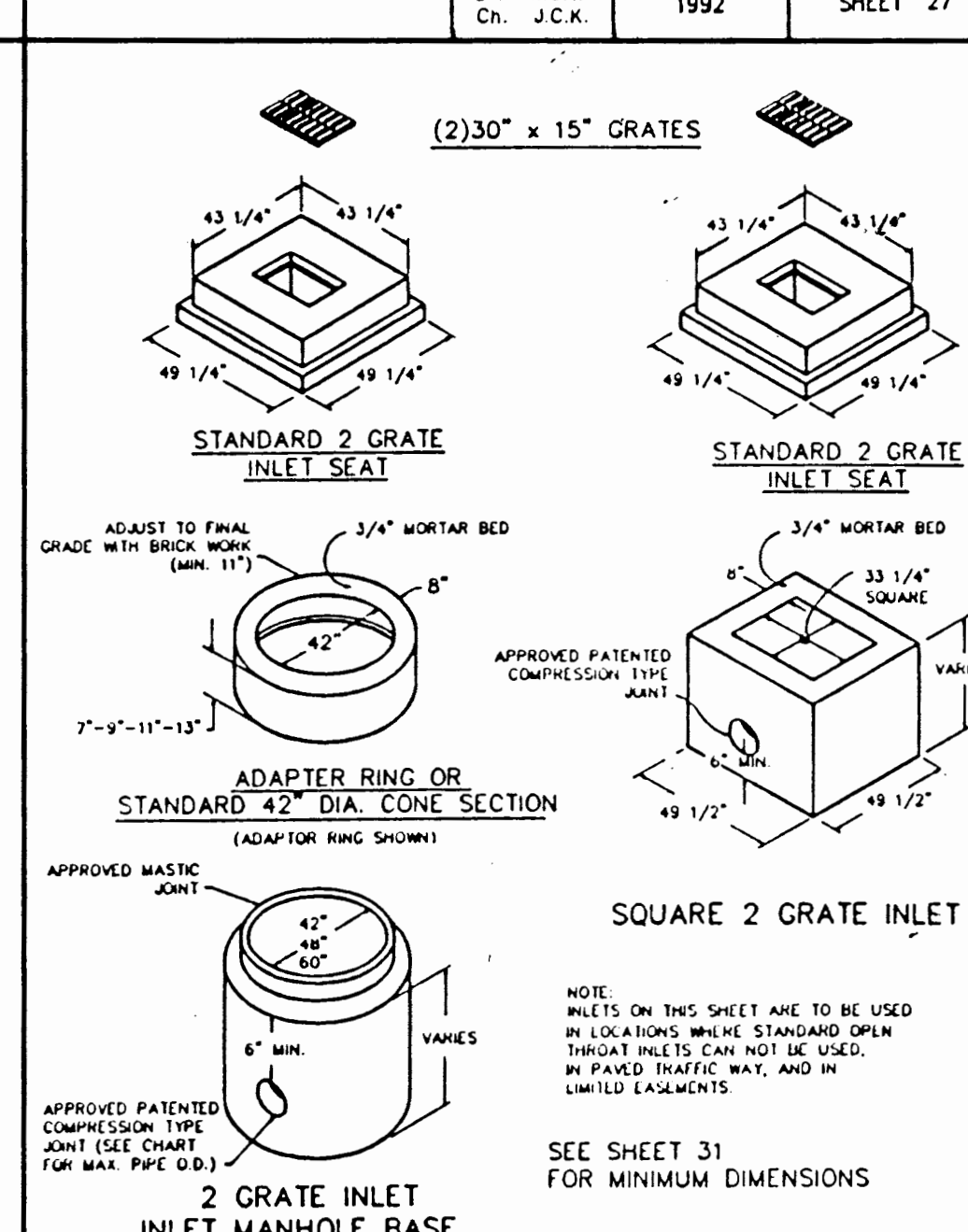

2 GRATE INLETS PRECAST CONCRETE  
METROPOLITAN ST. LOUIS SEWER DISTRICT  
Standard Details of Sewer Construction  
Dr. J.L.C. Ch. J.C.K. APRIL 1992 SHEET 33

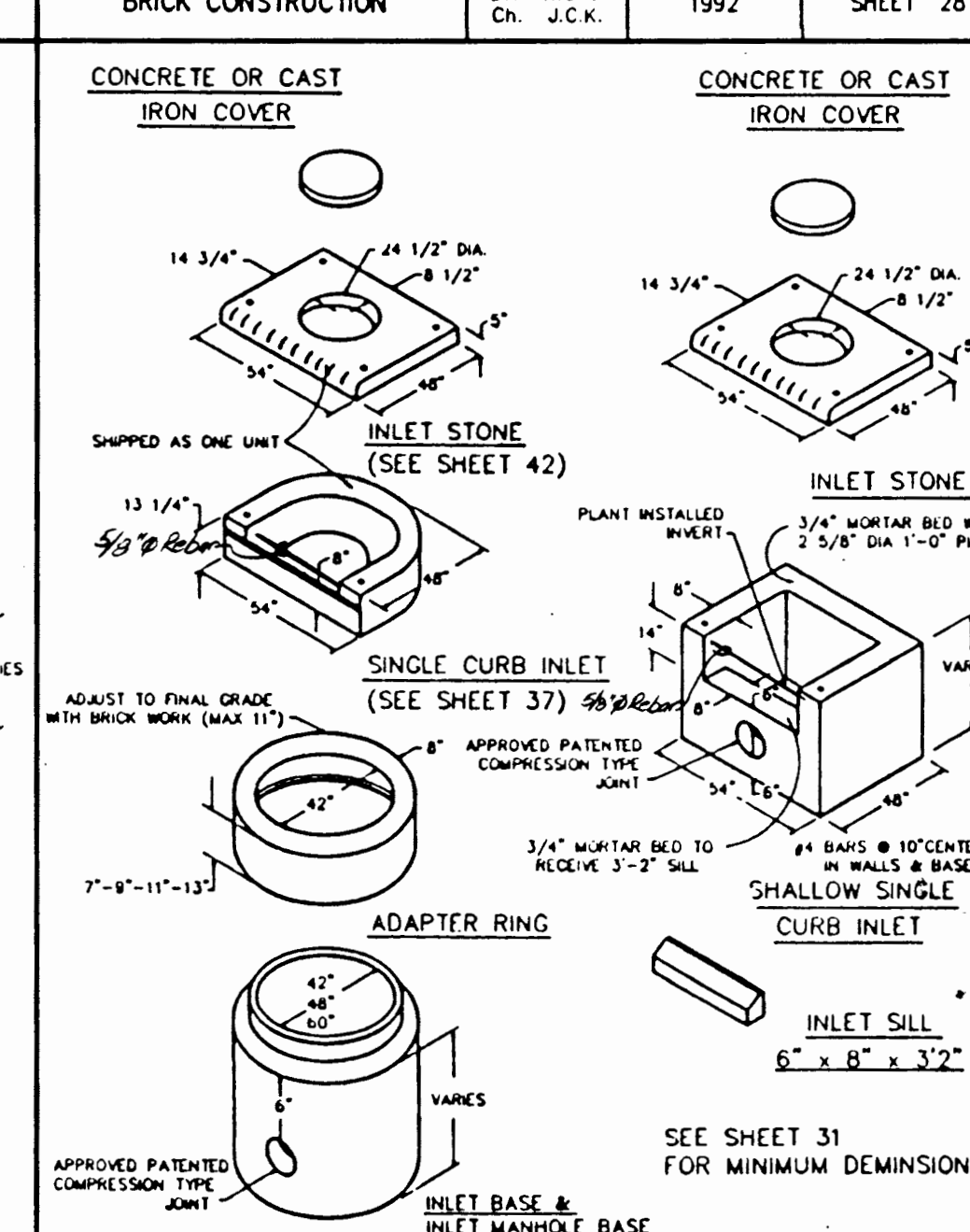

SINGLE STREET INLETS PRECAST CONCRETE  
METROPOLITAN ST. LOUIS SEWER DISTRICT  
Standard Details of Sewer Construction  
Dr. J.L.C. Ch. J.C.K. APRIL 1991 SHEET 34

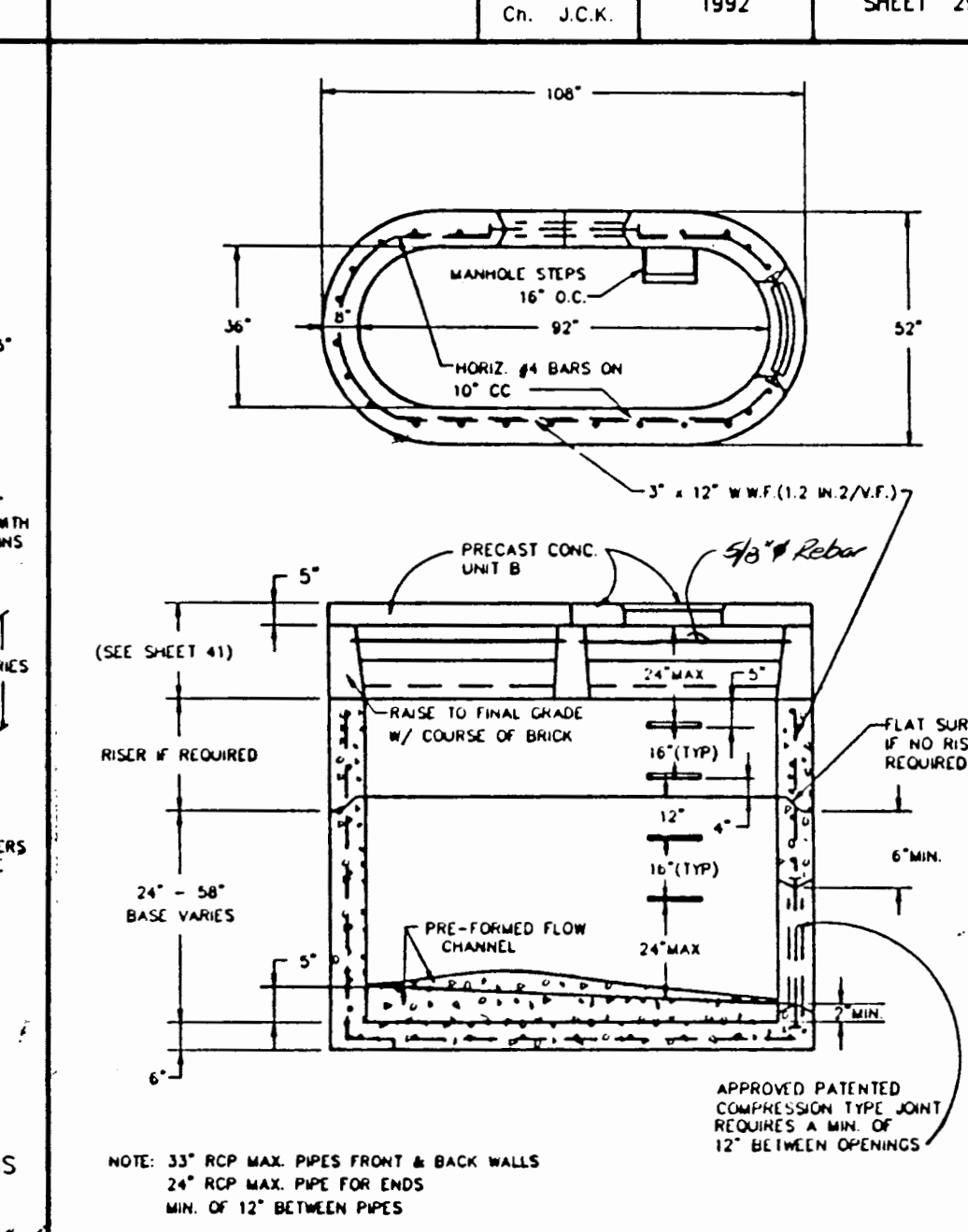

DOUBLE UNTRAPPED STREET INLET PRECAST CONCRETE  
METROPOLITAN ST. LOUIS SEWER DISTRICT  
Standard Details of Sewer Construction  
Dr. J.L.C. Ch. J.C.K. SEPT. 1992 SHEET 35

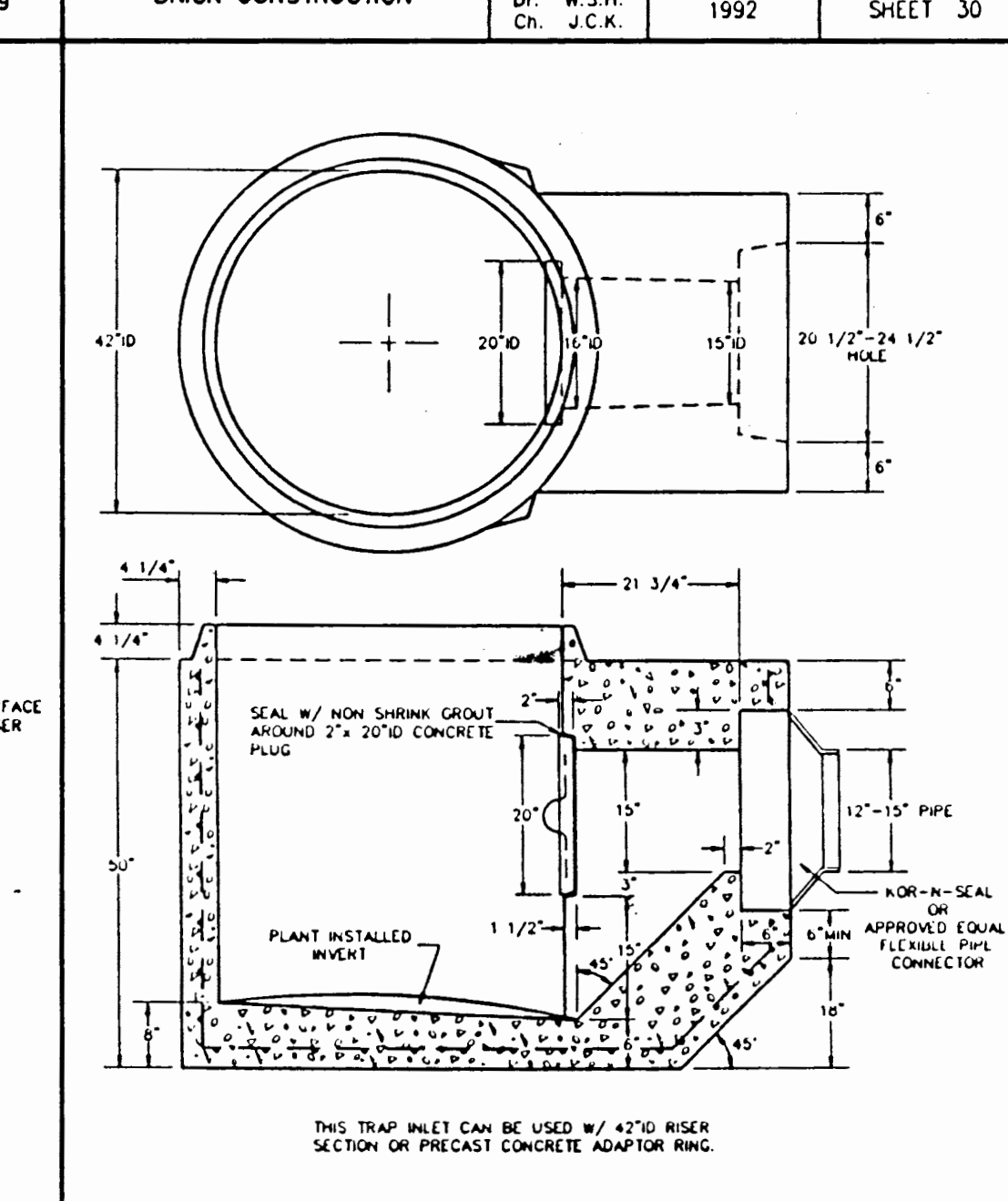

TRAPPED STREET INLET BASE PRECAST CONCRETE  
METROPOLITAN ST. LOUIS SEWER DISTRICT  
Standard Details of Sewer Construction  
Dr. W.S.H. Ch. J.C.K. 1992 SHEET 36