

USPS APPROVED SPECIFICATIONS – CONCRETE PAD (MULTIPLE UNIT)

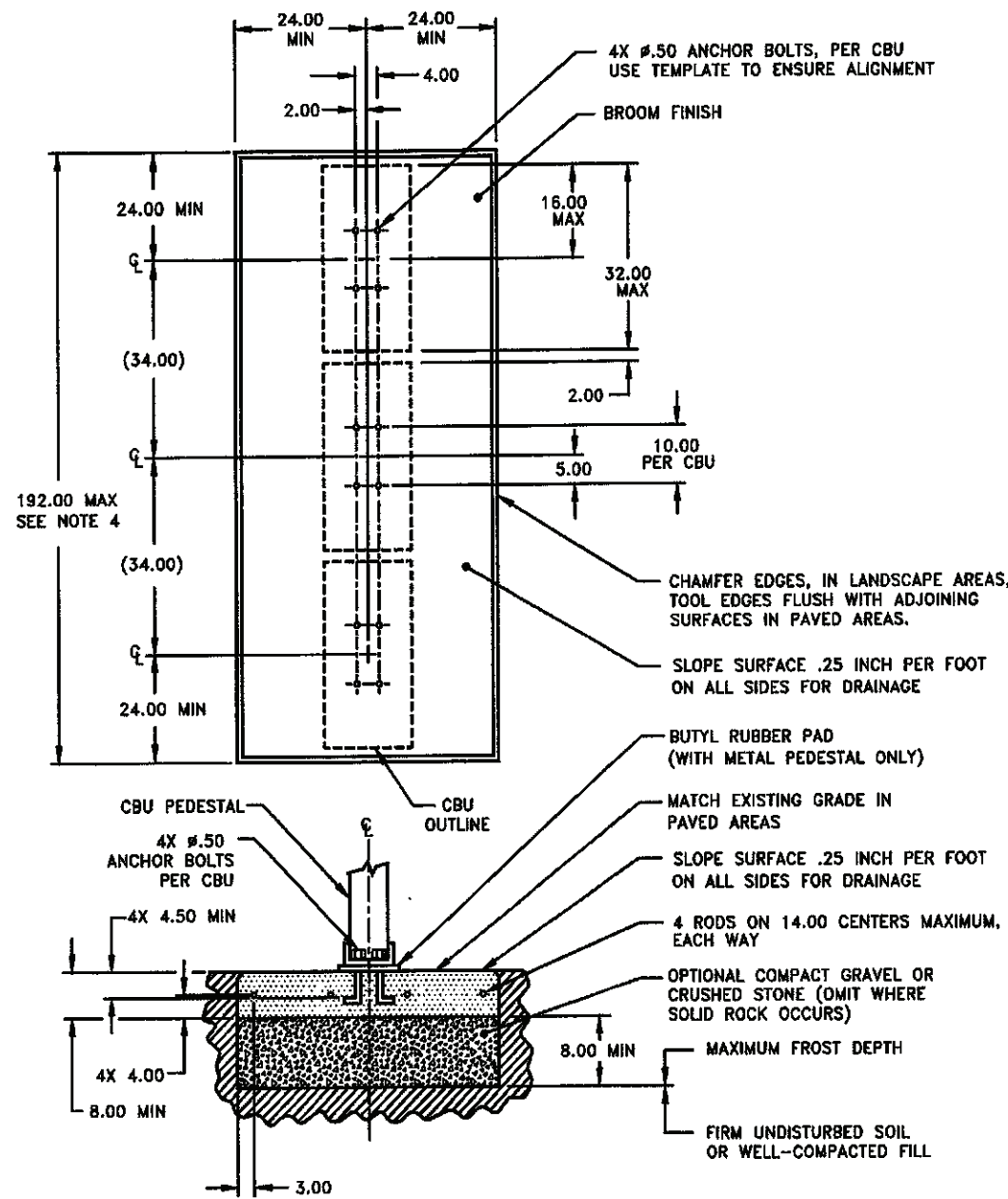

- NOTES:**
1. CONCRETE SHALL HAVE A COMPRESSIVE STRENGTH OF 3000 PSI @ 28 DAYS, CONTAIN 4X MIN - 6X MAX AIR ENTRAINMENT AND BE PLACED WITH A 3.50 - 4.50 SLUMP IN ACCORDANCE WITH ACI 301.
 2. REINFORCING STEEL RODS SHALL CONFORM TO ASTM A615, GRADE 60.
 3. ANCHOR BOLTS SHALL CONFORM TO ASTM A193, GRADE B16, TYPE 316 STAINLESS STEEL.
 4. A 3 CBU CONFIGURATION IS DEPICTED. A 2 OR 4 CBU CONFIGURATION MAY BE USED AS LONG AS THEY ARE ARRANGED IN GROUPS SUCH THAT THE OVERALL DIMENSION OF THE CONCRETE BASE DOES NOT EXCEED 192 INCHES.

**CLUSTER BOX UNIT (CBU)
-ANCHORING METHODS-**

CBU's must be level and mounted firmly in concrete, using one of the following methods.

1. The J-bolt method is the preferred method of installation of CBU's on concrete pads; however, the J-bolt pattern must be accurate with the CBU pedestal plate. When using J-bolts, in order to prevent any damage or accidents that could result from the exposed bolts, consideration should be given as to the time lapse between pouring the concrete and the actual installation. Expansion anchors must be installed in accordance with the manufacturer's instructions.
2. The use of anchor bolts for the installation of CBU's on concrete pads is also acceptable as long as the methods described below are followed.
 - a. Hilti Kwik bolt II, 1/2" diameter X 5-1/2" overall length
Catalog Number: 000-453-696, KB II 12-512
Stainless Steel Catalog Number: 000-454-744
Minimum embedment in concrete must be no less than 3-1/2"
 - b. ITW Ramset Redhead Trubolt, galvanized, 1/2" diameter X 7" overall length
 - c. Rawl Stud, 1/2" diameter X 5 1/2" overall length, galvanized.
Catalog Number: 7324
Minimum embedment in concrete must be no less than 4"

**CLUSTER BOX UNIT (CBU)
-CONCRETE PAD REQUIREMENTS-**

- ALL FREE STANDING PADS MUST BE 8" THICK -

1 UNIT	SINGLE PAD	4' X 4'
2 UNITS	DOUBLE PAD	4' X 7'
3 UNITS	TRIPLE PAD	4' X 10'
4 UNITS	QUAD PAD	4' X 13'

*** WHEN PLACING A PARCEL LOCKER AT ANY CBU LOCATION, INCREASE THE PAD SIZE BY AN ADDITIONAL 4' X 4' ***

**POSTAL SERVICE DETAILS
FOR MULTI-UNIT CBU PLACEMENT**

**ENGINEERS SEAL DOES NOT APPLY TO
U.S.P.S. DETAILS ON THIS SHEET.**



SPECIAL SIGN DETAIL
NOT TO SCALE

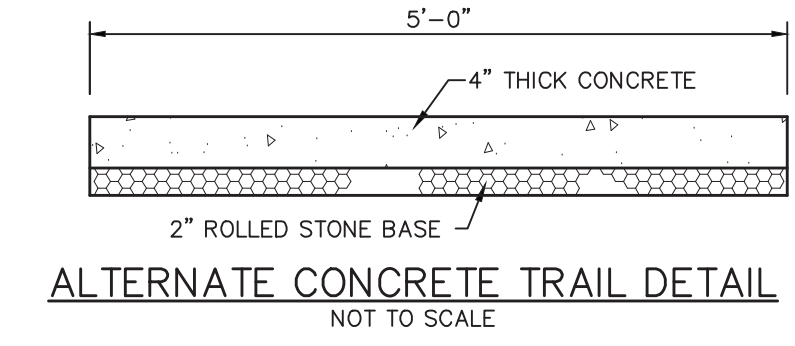

ALTERNATE CONCRETE TRAIL DETAIL
NOT TO SCALE

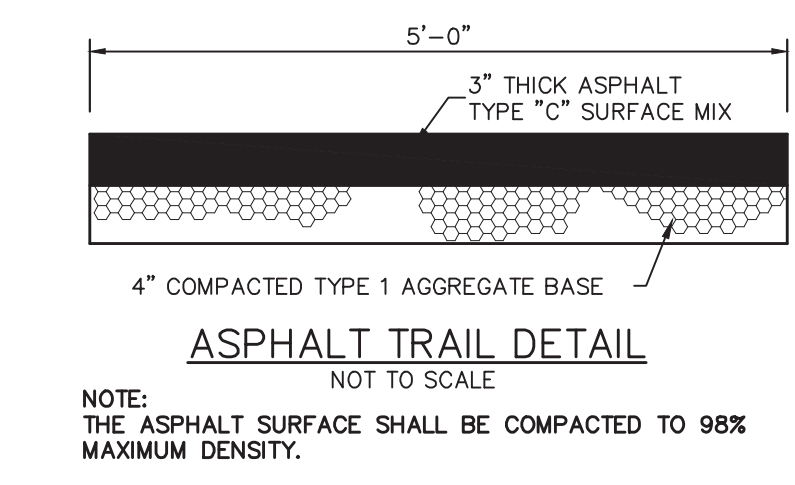

ASPHALT TRAIL DETAIL
NOT TO SCALE

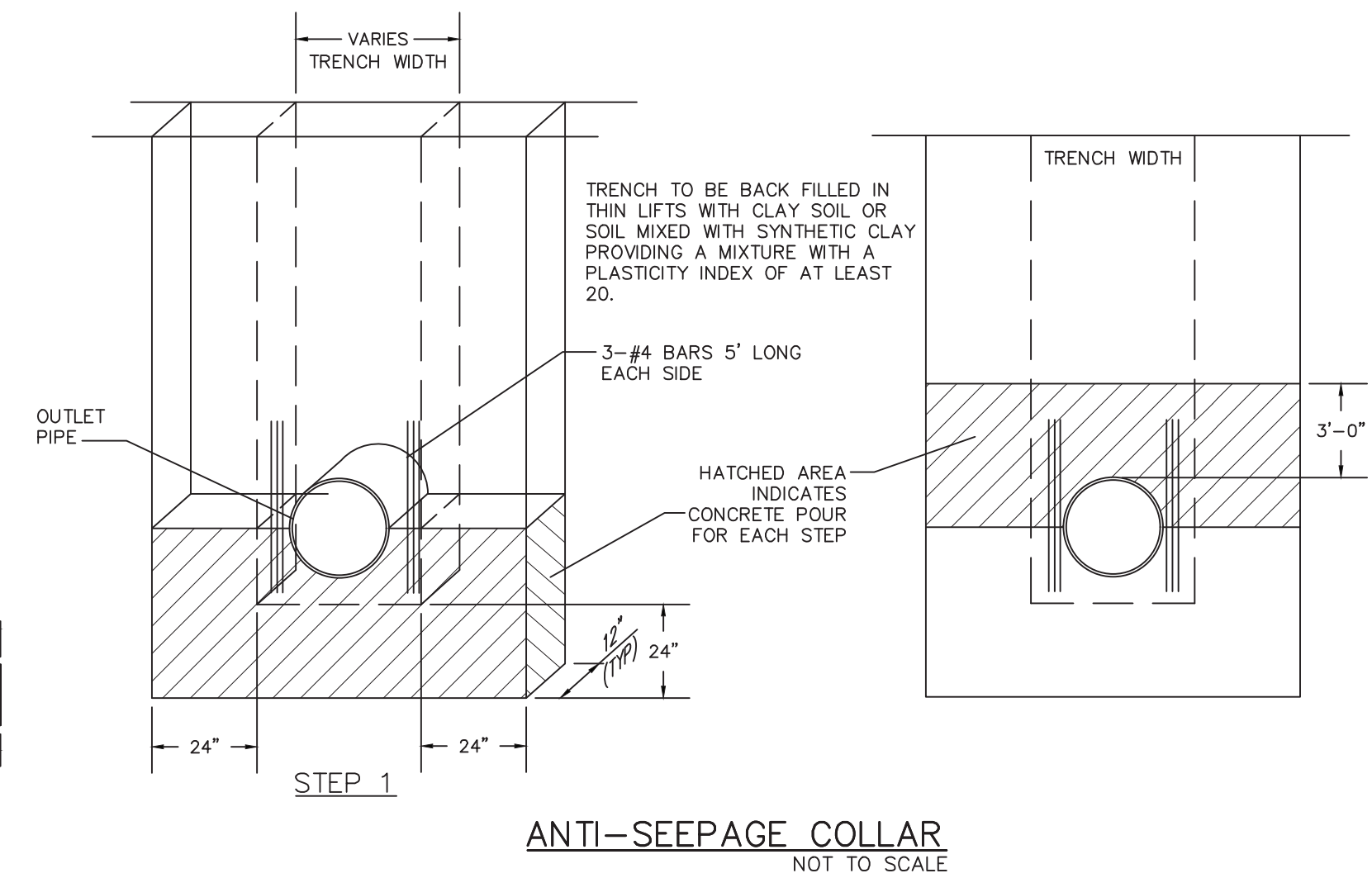

ANTI-SEEPAGE COLLAR
NOT TO SCALE

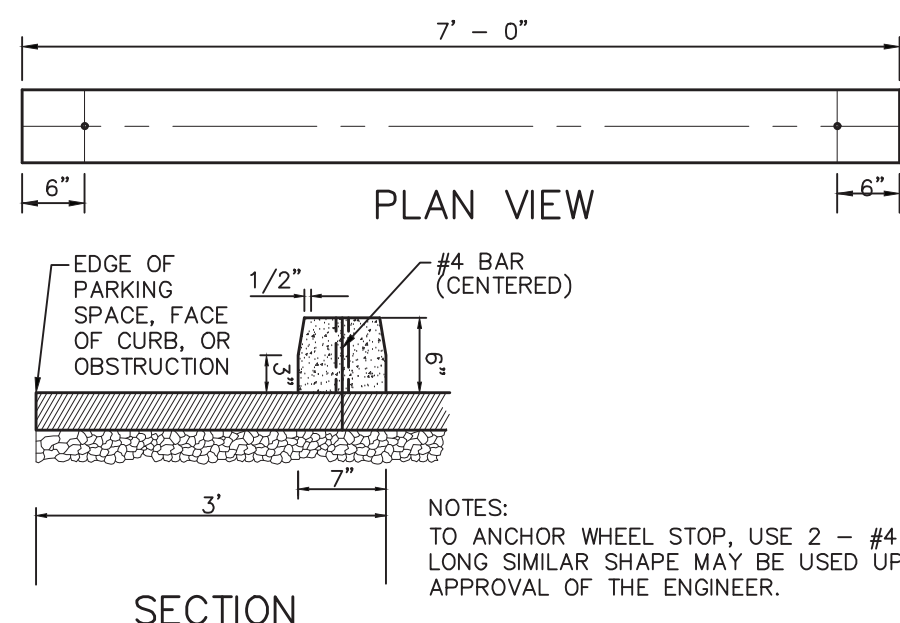

SECTION
NOTES:
TO ANCHOR WHEEL STOP, USE 2 - #4 BARS 24" LONG SIMILAR SHAPE MAY BE USED UPON APPROVAL OF THE ENGINEER.

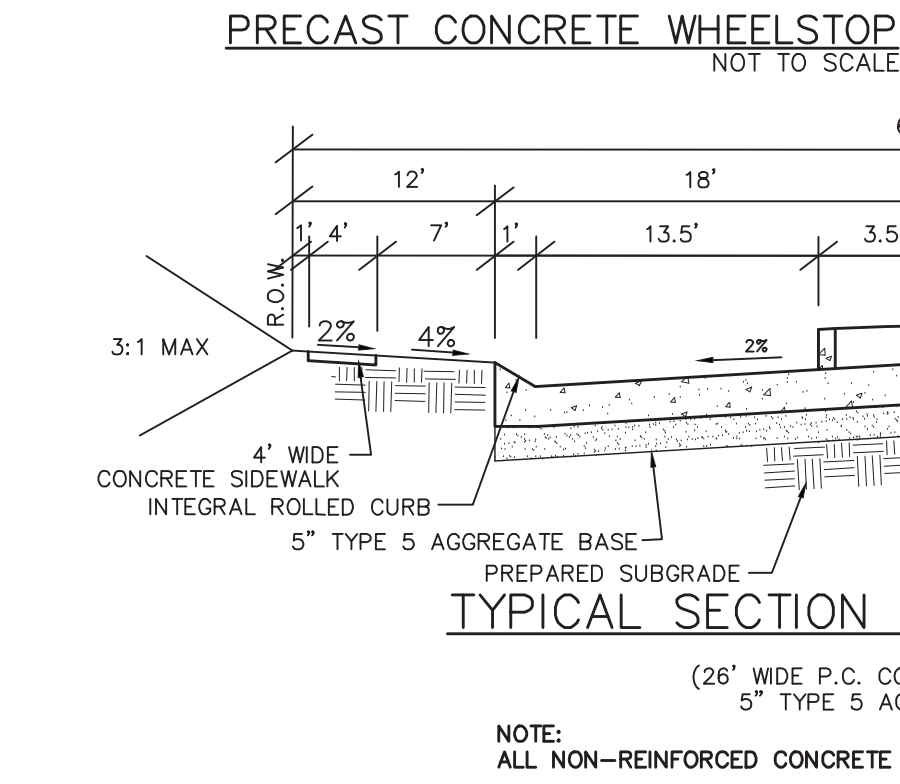

TYPICAL SECTION WITH CENTER ISLAND
NOT TO SCALE
NOTE: ALL NON-REINFORCED CONCRETE SHALL BE 4,000 P.S.I. AT 28 DAYS.

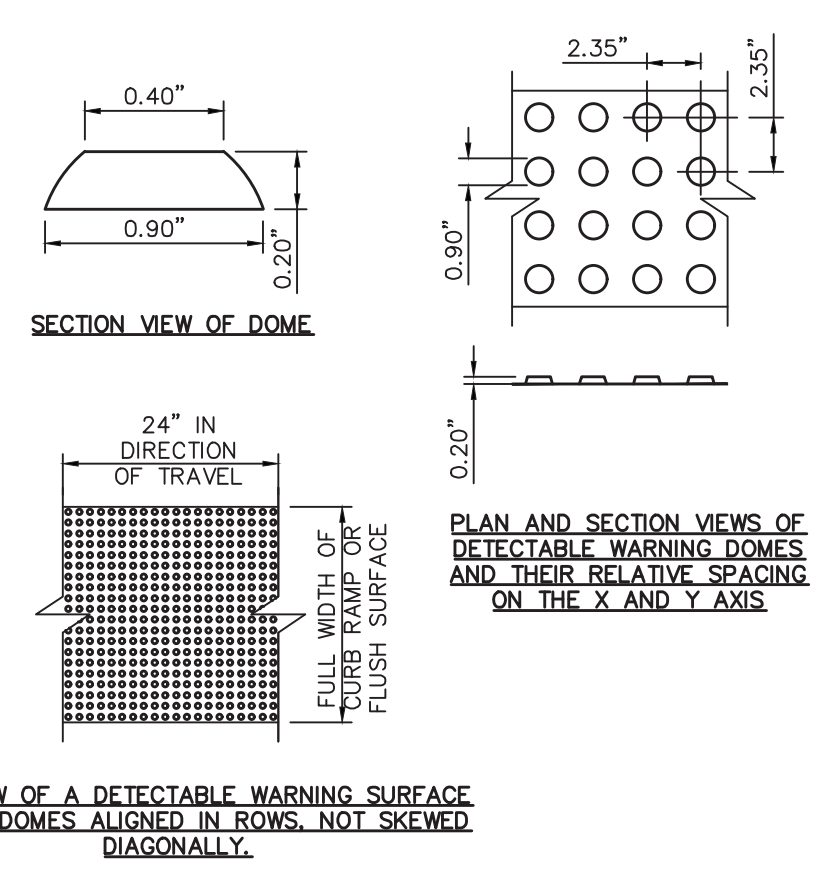

TYPICAL DETAIL OF DETECTABLE WARNING SURFACE
NOT TO SCALE

NOTE: TRUNCATED DOMES FOR CURB RAMPS LOCATED IN PUBLIC RIGHT-OF-WAY SHALL MEET ADA REQUIREMENTS AND SHALL BE CONSTRUCTED USING RED PRE-CAST TRUNCATED DOMES (NOT PRECAST CONCRETE) SUCH AS THOSE MANUFACTURED BY ARMOR TILE OR APPROVED EQUAL.

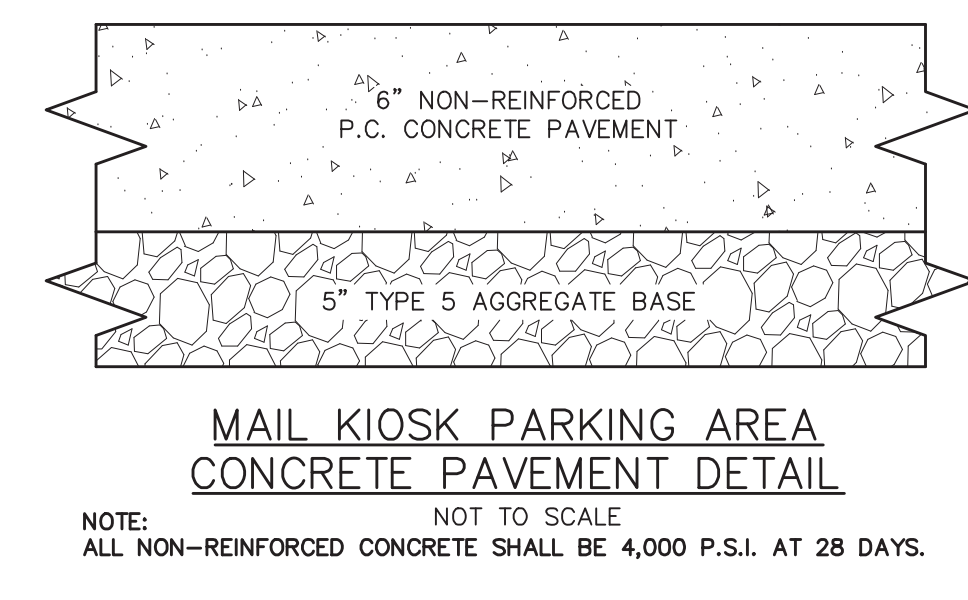

MAIL KIOSK PARKING AREA CONCRETE PAVEMENT DETAIL
NOT TO SCALE
NOTE: ALL NON-REINFORCED CONCRETE SHALL BE 4,000 P.S.I. AT 28 DAYS.

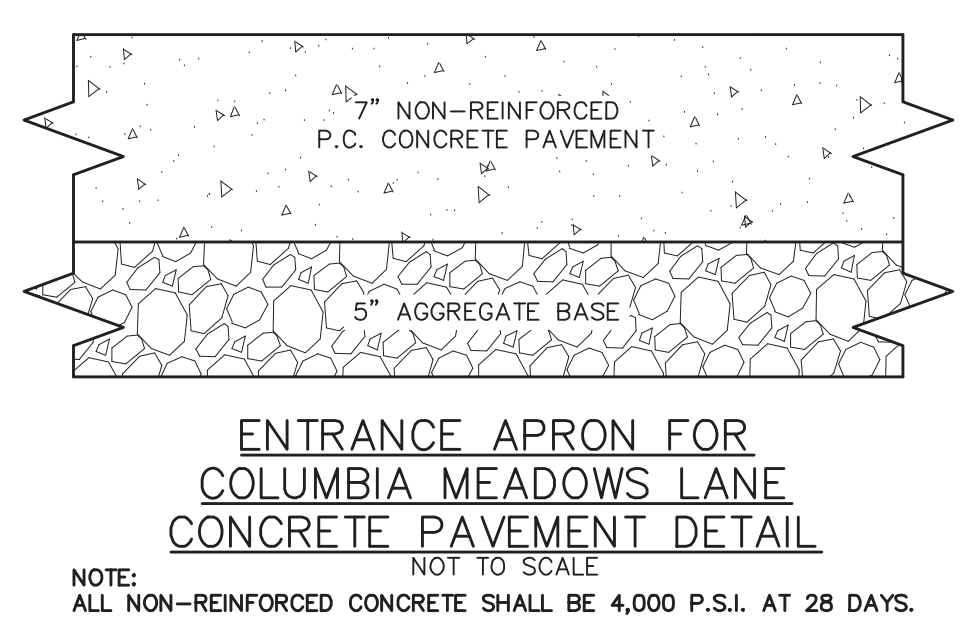

ENTRANCE APRON FOR COLUMBIA MEADOWS LANE CONCRETE PAVEMENT DETAIL
NOT TO SCALE
NOTE: ALL NON-REINFORCED CONCRETE SHALL BE 4,000 P.S.I. AT 28 DAYS.

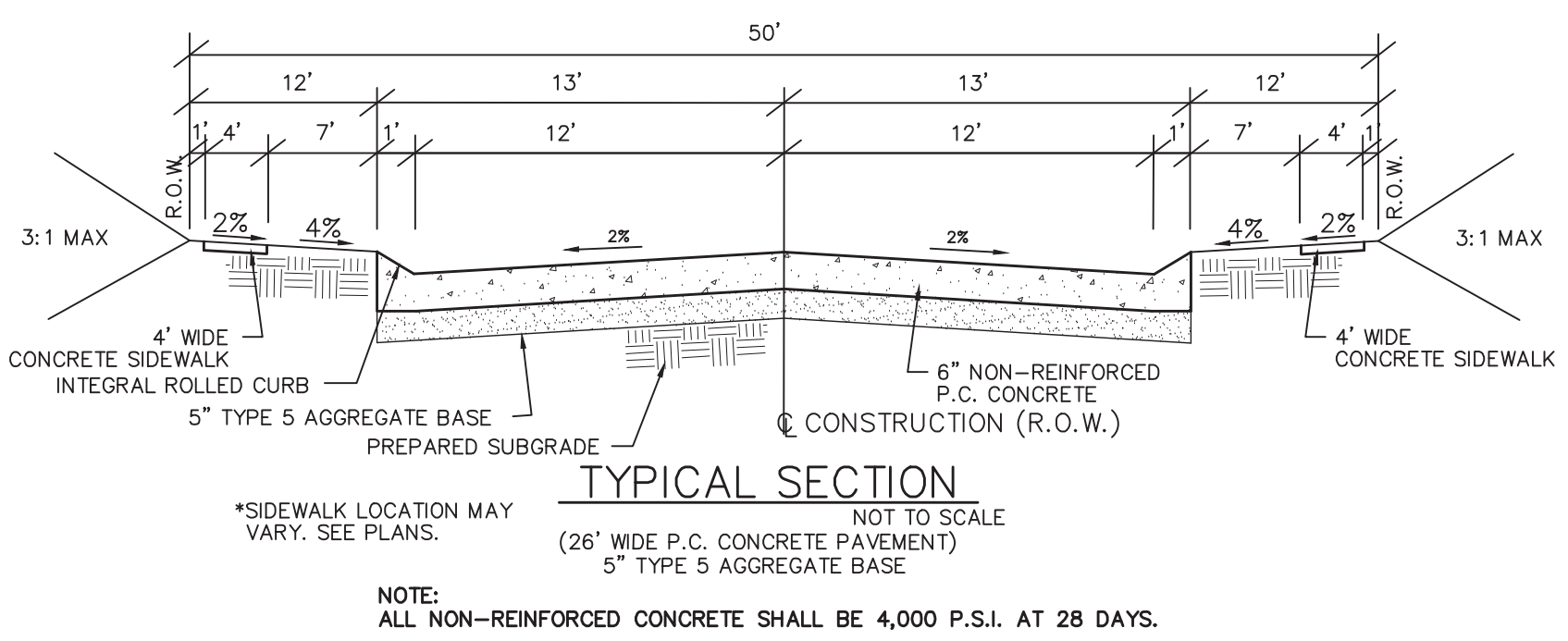

TYPICAL SECTION
NOT TO SCALE
NOTE: ALL NON-REINFORCED CONCRETE SHALL BE 4,000 P.S.I. AT 28 DAYS.

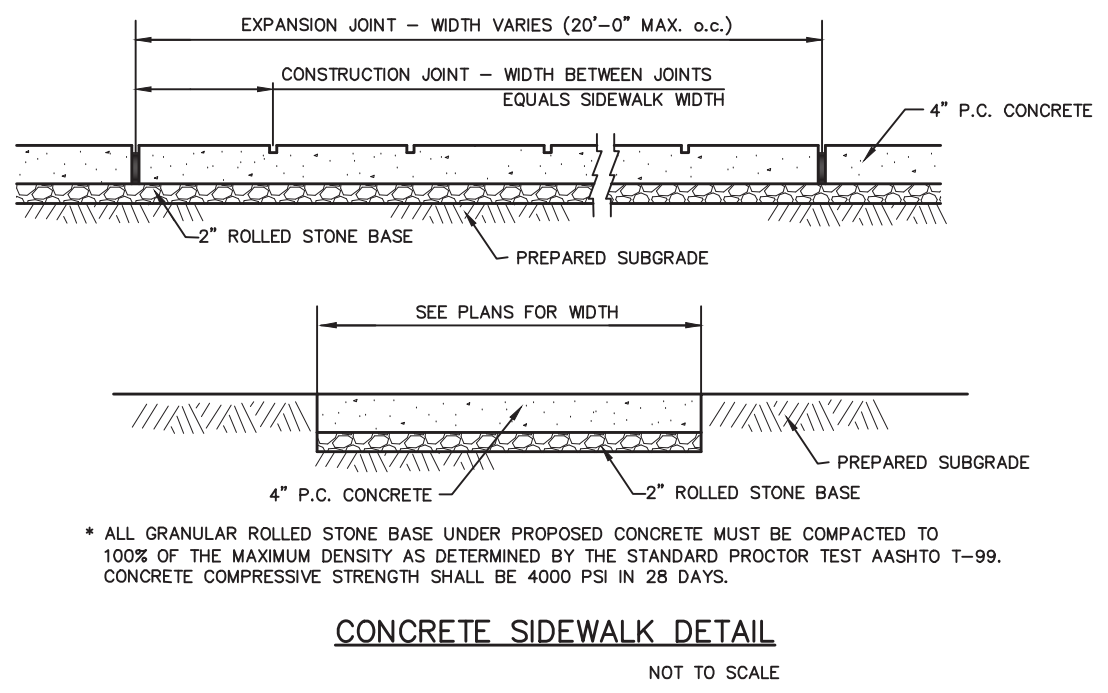

CONCRETE SIDEWALK DETAIL
NOT TO SCALE

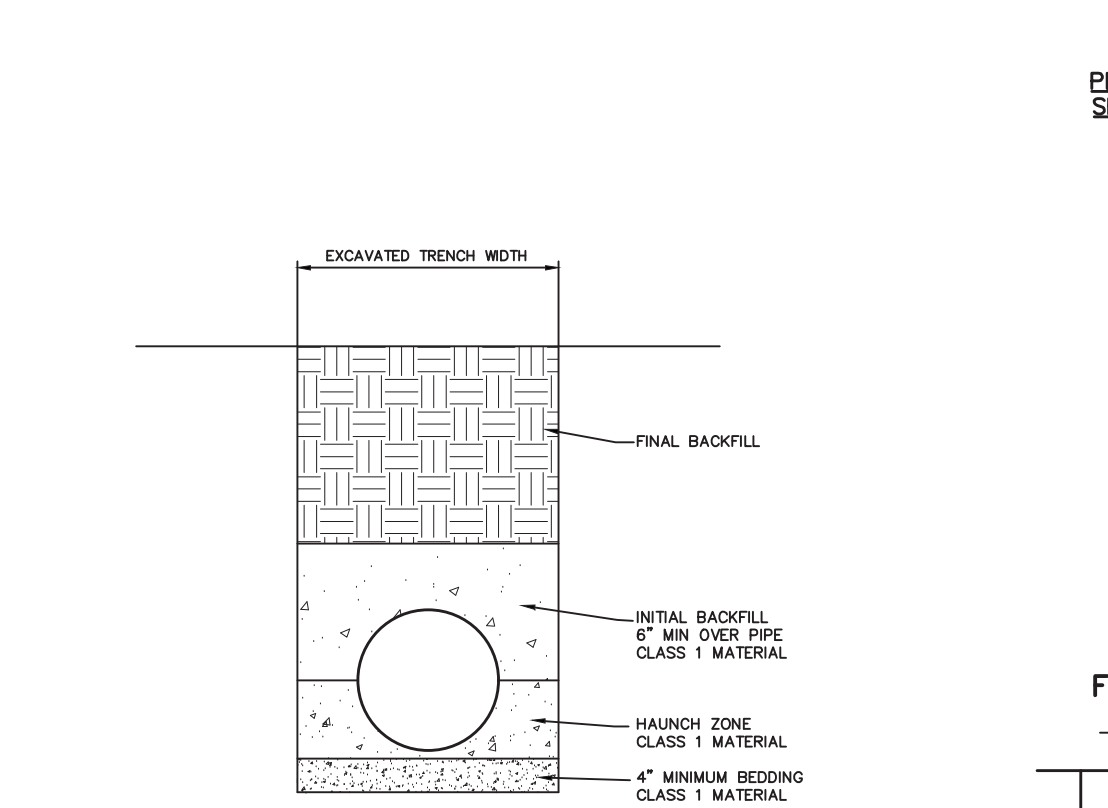

1. The use of High Density Polyethylene Corrugated pipe A.D.S. N12 or Equal will be permitted as an acceptable alternative to reinforced concrete pipe. Pipe shall meet A.S.T.M. D-2521 and AASHTO M-294-92T. Concrete lined and sections and inlet structures shall be required. Pipe must have smooth interior wall and is not to be used inside the Public Right-of-Way. All concrete pipe or HDPE pipe shall be installed with o-ring rubber type gaskets per U.S.D. Standard Construction Specifications or Manufacturer.

2. In typical conditions the minimum trench width is determined by the size of the pipe and the ability to get compaction equipment between the pipe and the trench walls. The minimum trench width should not be less than the outside diameter plus 16 inches or the pipe outside diameter times 1.25 plus 12 inches, whichever is greater. High speed trenchers may enable satisfactory installation of pipe in narrower trenches. Poor traffic conditions such as potholes, running sands, or repetitive slope will require substantially wider berms as well as deeper foundation and bedding. Trench width and foundation depth should be based on a thorough site investigation.

3. Backfill in the area up to the springline should be carefully placed and compacted to achieve a minimum C value of 1,000 psi as detailed in ASTM D2922. A minimum of 12" of backfill should be placed and compacted above the crown of the pipe. It is typical for trenches to be backfilled entirely with Type 1 or Type II material when under pavement.

4. Flexible pipe should never be installed in a concrete cradle, as done for rigid pipe in a Cradle A installation. This type of installation could create concentrated forces at the ends of the cradle when the pipe has deflected.

H.D.P.E. PIPE DETAIL

PROJECT TITLE:

**COLUMBIA
MEADOWS**

ENGINEERING
PLANNING
SURVEYING
221 Point View Blvd
St. Charles, MO 63001
636-928-5562
FAX 636-928-1718

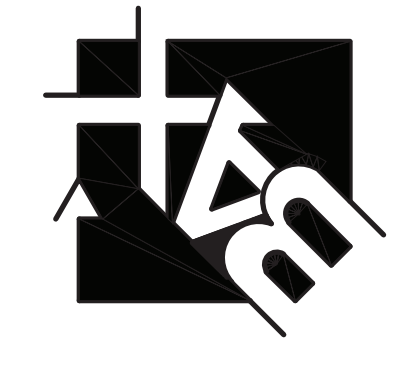

DISCLAIMER OF RESPONSIBILITY
I hereby specify that the documents intended to be authorized by my seal are limited to this sheet, and I hereby disclaim any responsibility for all other drawings, specifications, estimates, reports or other documents or instruments relating to or intended to be used for any part or parts of the architectural or engineering project or projects herein.



JEFFREY B. SIMMONS
CIVIL ENGINEER
2007030831
Copyright 2020
Box Engineering Company, Inc.
Authority No. 000655
All Rights Reserved

REVISIONS

10/13/20	CITY COMMENTS
01/08/21	CITY COMMENTS
02/10/21	CITY COMMENTS
02/23/21	CITY COMMENTS

Developer / Owner:
Alpha Land Development Two, L.L.C.
612 Trade Center Boulevard
Chesterfield, MO 63005
314-721-7779

CONSTRUCTION DETAILS

P+Z No. #19-004868
Approval Date: 07/23/2020
City No. #?
Page No. 34 of 38