

ROUND PIPE				HORIZONTAL ELLIPTICAL PIPE			
Inside Diameter of Pipe (Inches)	"w" (Payline Width of Trench (Inches))	"W" (Payline Width of Trench (Feet))	Pay-volume as ft. per ft. of Concrete Encasement	Inside Diameter of Pipe (Inches)	"w" (Payline Width of Trench (Inches))	"W" (Payline Width of Trench (Feet))	Pay-volume as ft. per ft. of Concrete Encasement
4	28	2.33	3.20				
6	28	2.33	3.46				
8	28	2.33	3.70				
10	28	2.33	3.86				
12	28	2.33	3.98				
15	32	2.67	4.88				
18	35	2.92	5.63	14 x 23	41	3.42	5.94
21	39	3.25	6.61				
24	42	3.50	7.38	19 x 30	49	4.08	7.68
27	45	3.75	8.18	22 x 34	53	4.42	8.61
30	49	4.08	9.30	24 x 38	58	4.83	9.70
33	53	4.42	10.53	27 x 42	62	5.17	10.71
36	56	4.67	11.43	29 x 45	66	5.50	11.72
39	60	5.00	12.50	32 x 49	71	5.92	13.14
42	63	5.25	13.38	34 x 53	75	6.25	14.25
48	70	5.83	15.67	38 x 60	83	6.92	16.18
54	77	6.42	18.15	43 x 68	92	7.67	18.81
60	84	7.00	20.23	48 x 76	101	8.42	21.58
66	91	7.58	23.45	53 x 83	109	9.08	24.35
72	98	8.17	26.37	58 x 91	118	9.83	27.45
78	105	8.75	29.39	63 x 98	126	10.50	30.50
84	112	9.33	32.57	68 x 106	135	11.25	33.91
90	119	9.92	35.90	72 x 113	143	11.92	36.98
96	126	10.50	39.37	77 x 121	152	12.67	40.68
102	133	11.08	42.99	82 x 128	160	13.33	44.45
108	140	11.67	46.75	87 x 136	168	14.00	47.79
114	147	12.25	50.66	92 x 143	176	14.67	51.70
120	154	12.83	54.72	97 x 151	185	15.42	56.01
126	161	13.42	58.92				
132	168	14.00	63.27	106 x 166	202	16.83	64.48
144	182	15.17	72.40	116 x 186	218	18.17	73.59

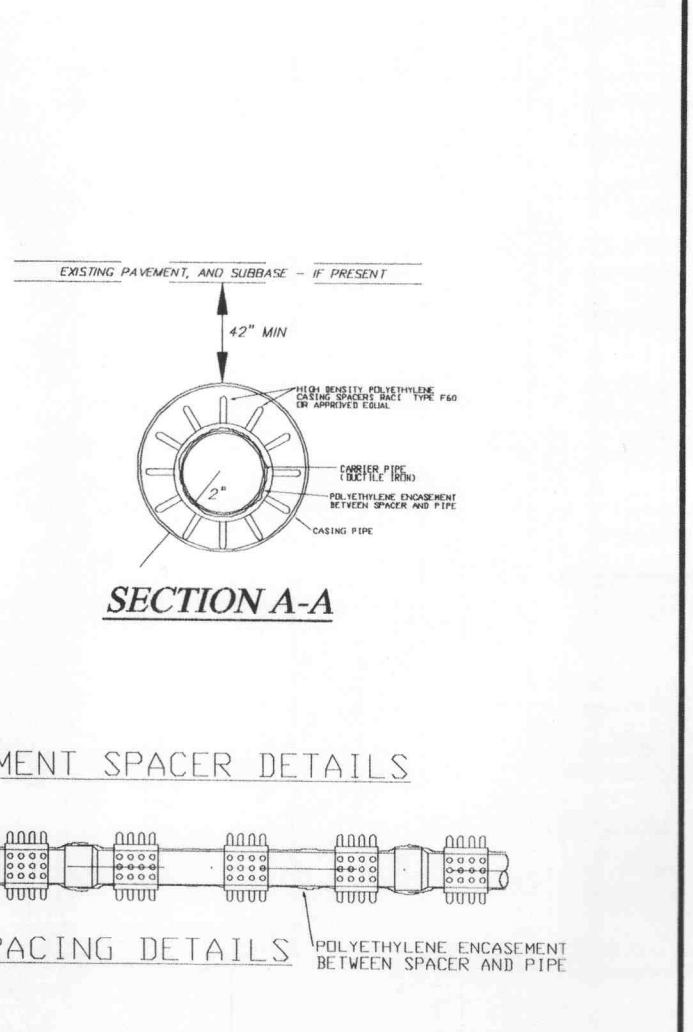
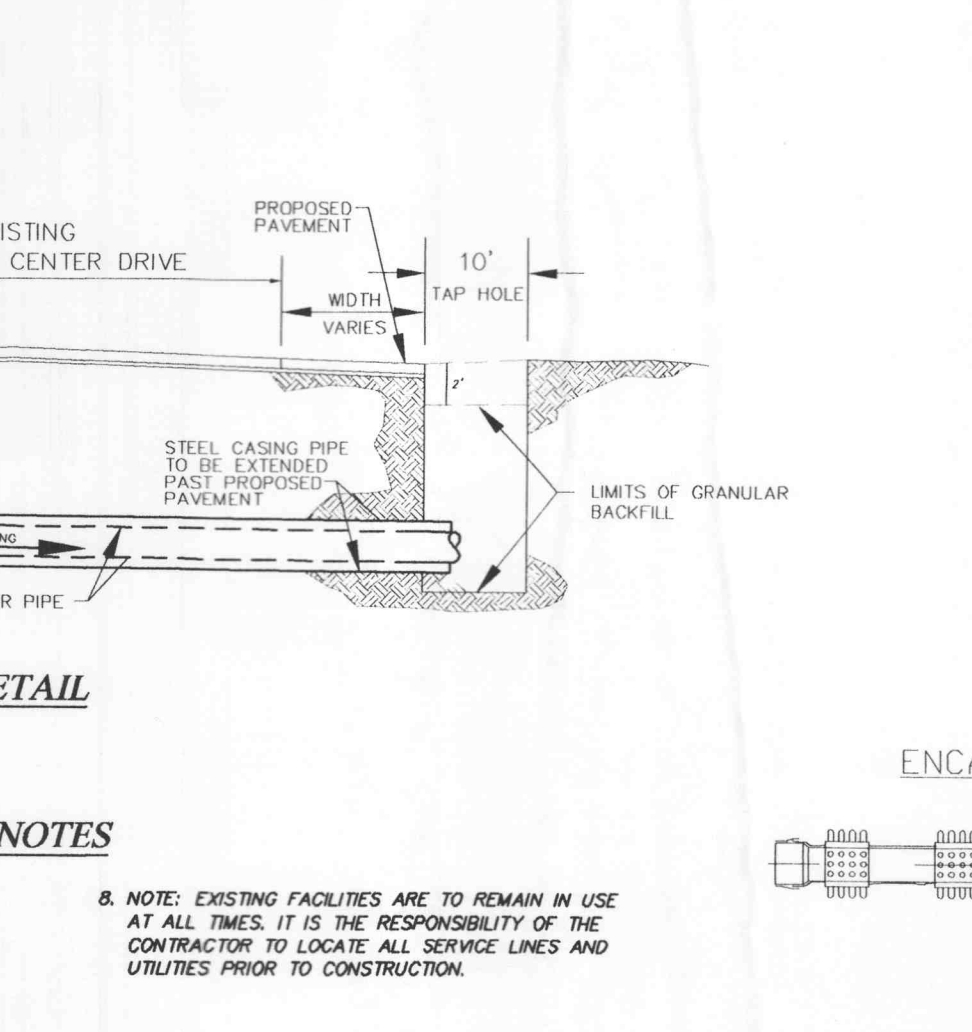
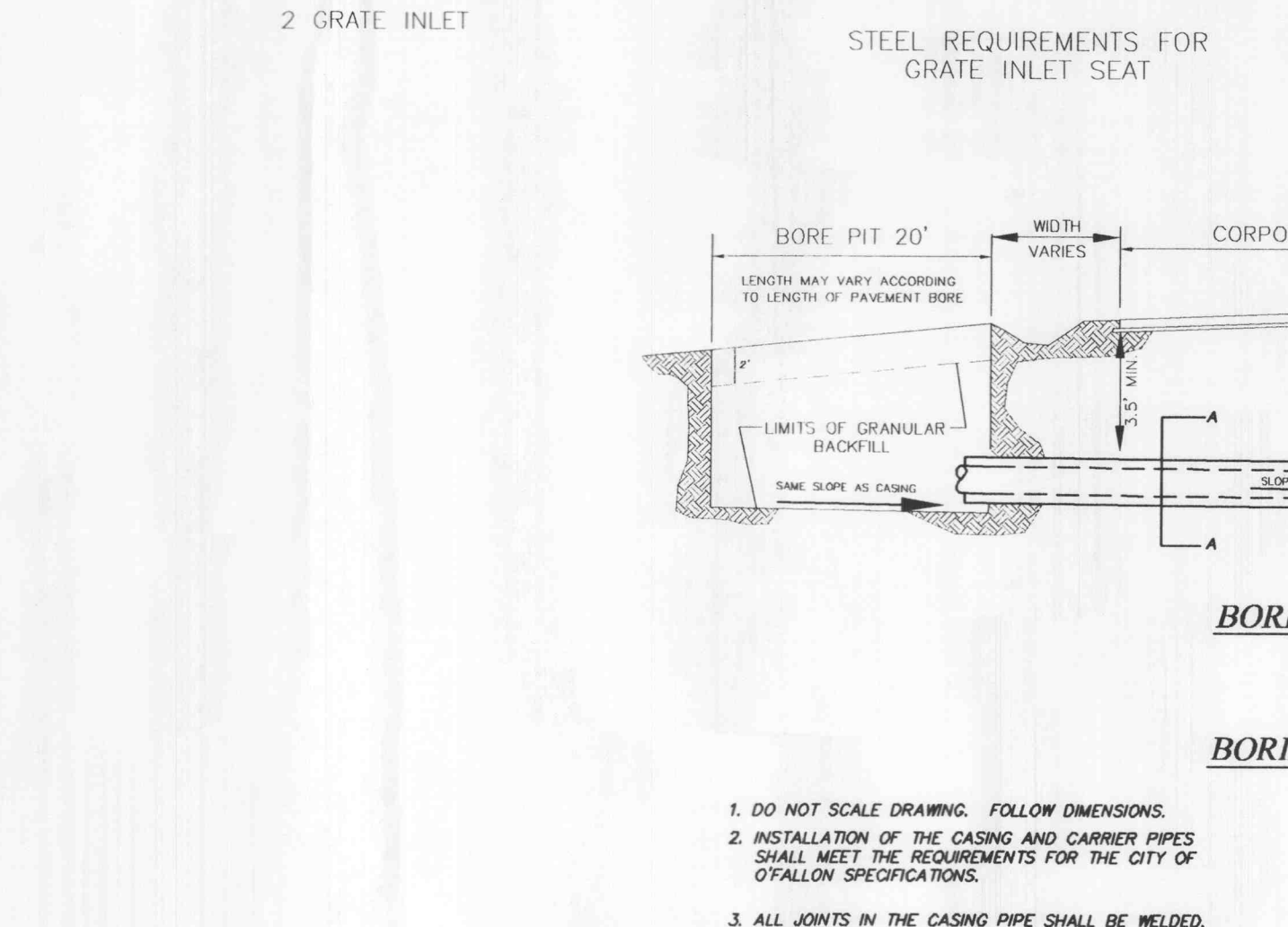
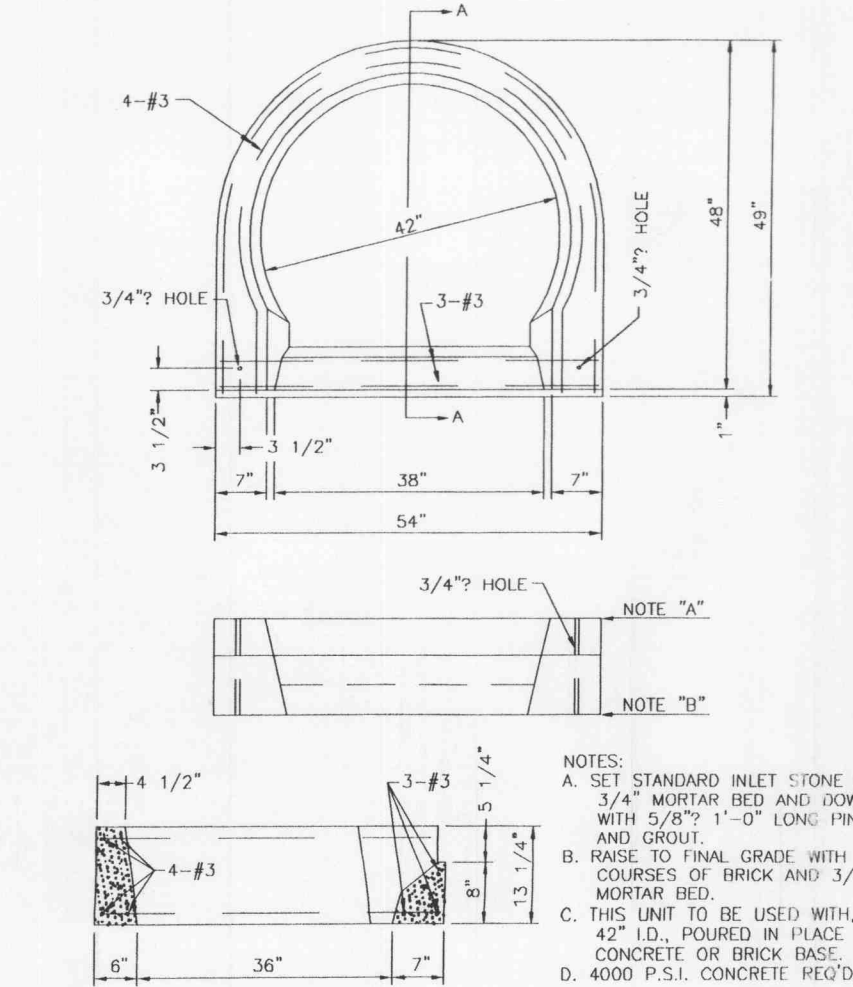
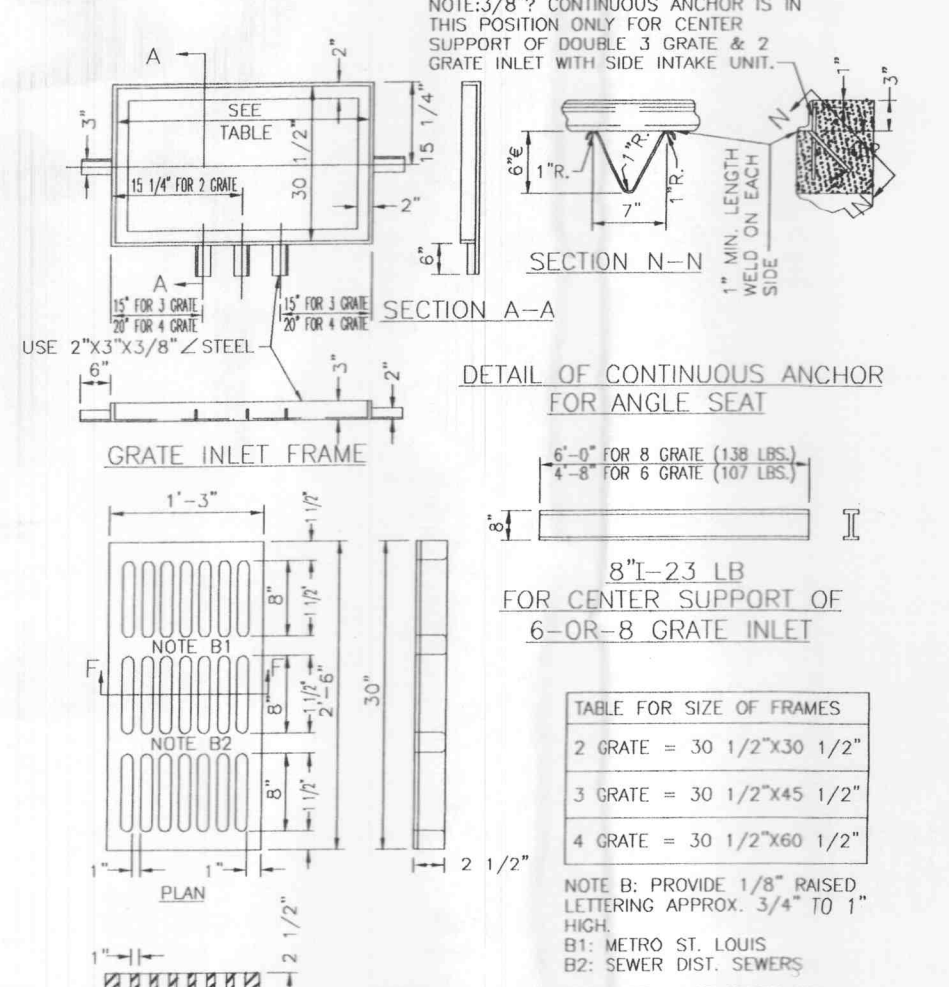
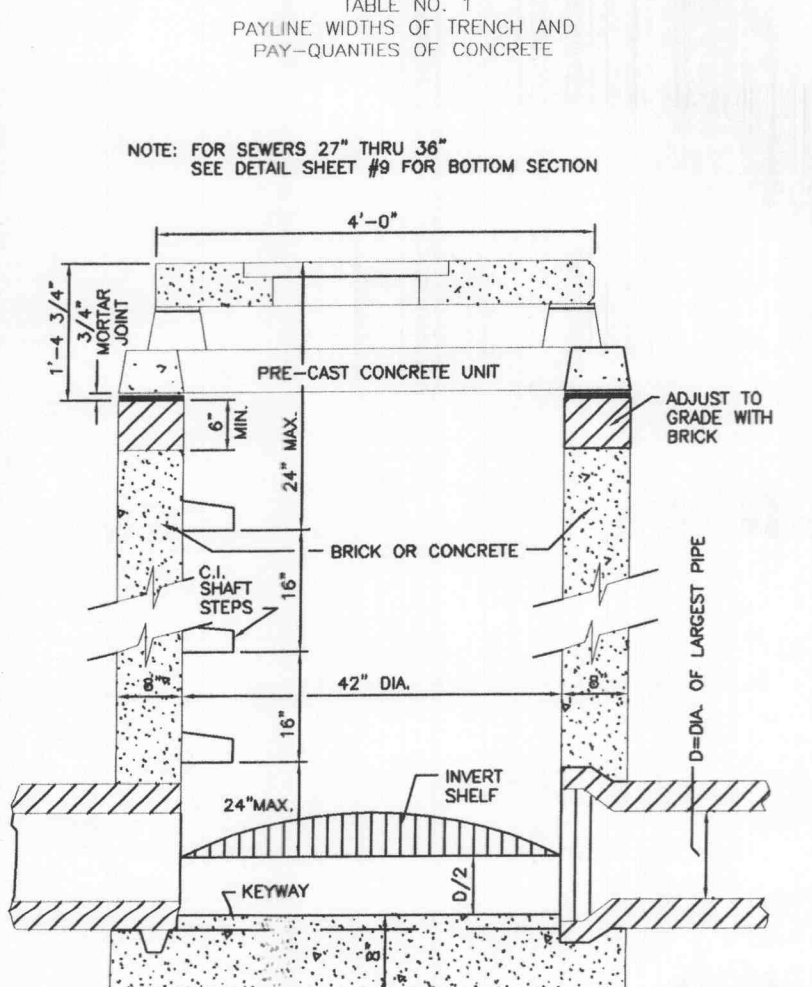
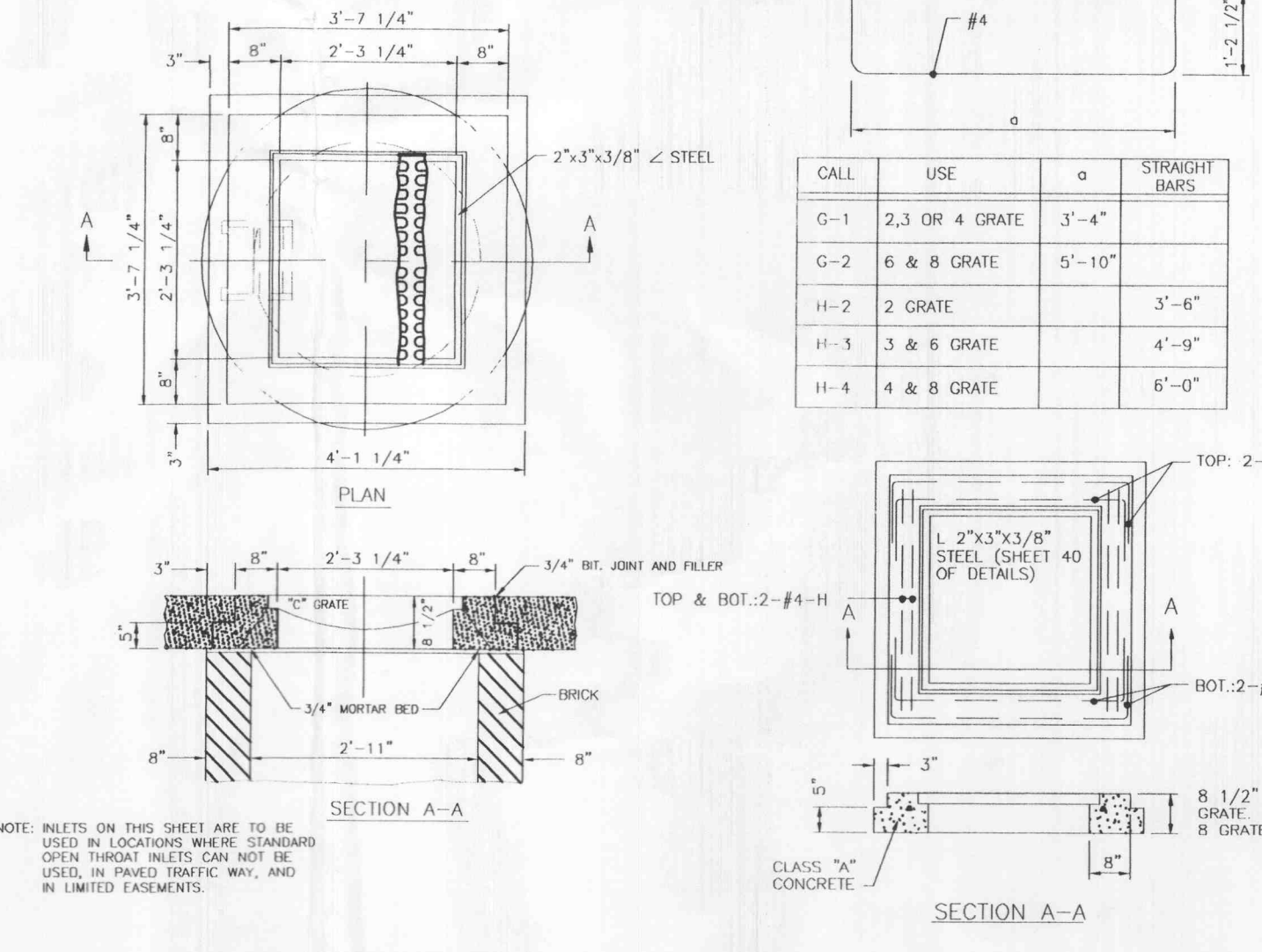
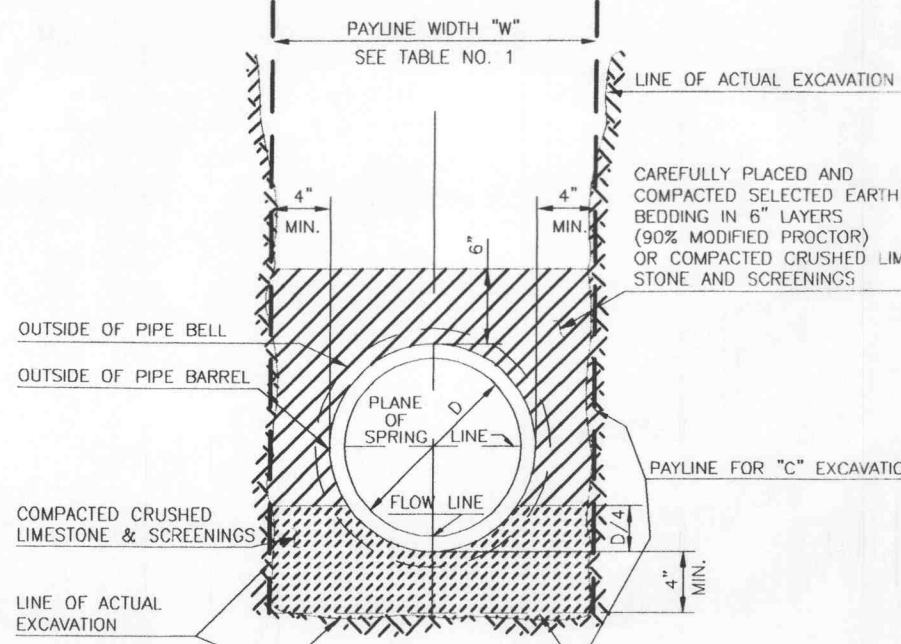
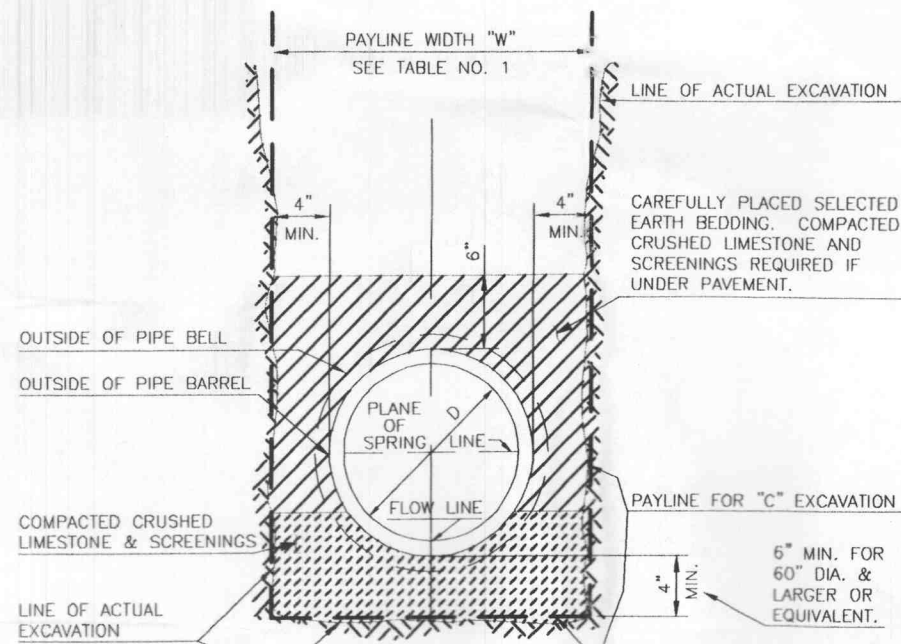

AREA INLET (12\"/>

DETAILS OF INLET FRAME AND GRATES

PRECAST CONCRETE UNIT FOR SINGLE CURB INLET

BORE NOTES

ENCASEMENT SPACER DETAILS

SPACING DETAILS

**PICKETT RAY & SILVER**  
 CIVIL ENGINEERS  
 LAND SURVEYORS  
 383 Mid Rivers Mall Drive  
 St. Peters, MO 63376  
 Phone (636) 397-1211  
 Fax (636) 397-1104

**CON-FORM INTERNATIONAL, INC.**  
 OF FALLON CORPORATE CENTRE LOT 7A-2  
 SEWER PROFILES  
 OF FALLON, MISSOURI  
 Property Owner:  
**CON-FORM INTERNATIONAL, INC.**  
 1164 FAIRBOURNE INDUSTRIAL BLVD.  
 WYOMING AND COUNTY, MO 65453  
 PHONE (314) 992-8899  
 FAX (314) 992-8898

REVISIONS	DATE	BY	DESCRIPTION
01-03-03		PER CITY OF OF FALLON	
01-17-03		PER DUCKETT CREEK SEWER DISTRICT	
02-27-03		PER CITY OF OF FALLON & IRE DISTRICT	
03-10-03		PER CITY OF OF FALLON	
03-25-03		PER CITY OF OF FALLON	

**ENGINEERS AUTHENTICATION**  
 The responsibility for professional engineering liability on this project is hereby limited to the set of plans authenticated by the seal, signature, and date hereunder attached. Responsibility is disclaimed for all other engineering plans involved in this project and specifically excludes revisions after this date unless reauthenticated.  
**PICKETT RAY & SILVER, INC.**  
 HAROLD J. BARNICH  
 LICENSED PROFESSIONAL ENGINEER  
 NUMBER E-7751

DRAWN D. STOSZ DATE 08-02-07  
 CHECKED D.W.B. DATE 08-02-07  
 PROJECT # 95144.SMWI.OOC  
 TASK # 1 FIELD BOOK  
**CON-FORM INTERNATIONAL, INC.**  
 SEWER PROFILES  
 SHEET 5 OF 8  
 FILE #502.01  
 Copyright 2002 by Pickett, Ray & Silver, Inc.