

- NOTES:
- CONTRACTOR TO OBTAIN RIGHT-OF-WAY CONSTRUCTION UTILITY PERMIT FROM THE JOHNSON COUNTY KANSAS PUBLIC WORKS DEPARTMENT AND NOTIFY THEM FOR INSPECTION PRIOR TO ANY REPAIRS. SEE APPENDIX C OF THE SPECIFICATIONS FOR COPY OF UTILITY PERMIT FORM.
  - ACTUAL TRENCH SIDESLOPE TO BE DETERMINED BY CONTRACTOR IN ACCORDANCE WITH OSHA STANDARDS.
  - SEE PLAN SHEETS FOR LOCATION OF TRANSMISSION MAIN WITHIN STREET AND ROADWAYS.
  - THE DIMENSION OF THE GRANULAR EMBEDMENT ABOVE THE TOP OF THE TRANSMISSION MAIN SHALL BE 1/8 TIMES COVER, 6" MIN.
  - ASPHALTIC CONC BASE COURSE OR CONC CAP AS REQUIRED BY APPLICABLE CITY OR COUNTY.

**STREET TRENCHING DETAIL AND CROSSING SECTION**  
NO SCALE

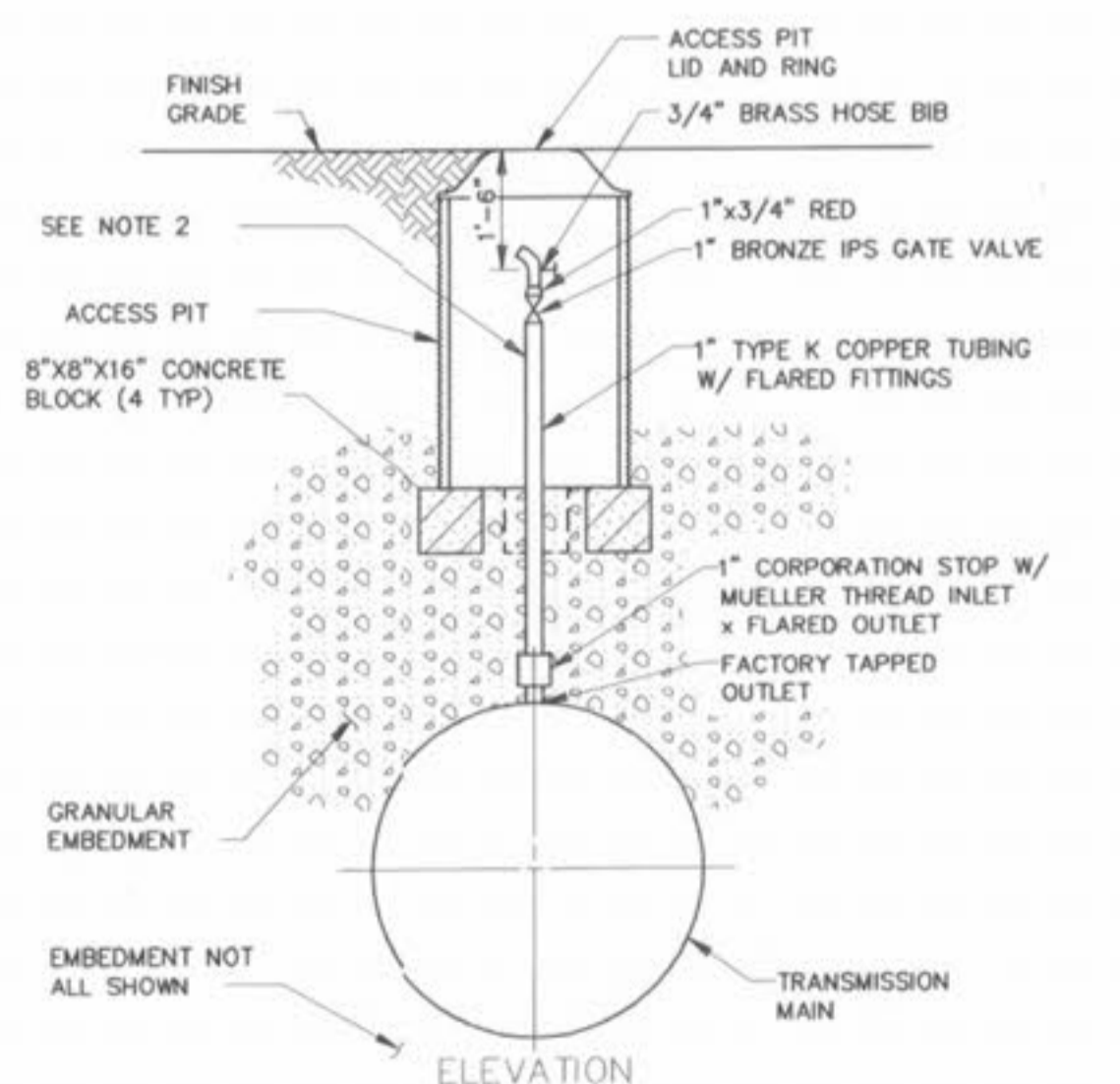

- NOTES:
- SEE PLAN AND PROFILE SHEETS FOR LOCATIONS OF MANUAL AIR RELEASE VALVE ASSEMBLIES. WHERE THE TRANSMISSION MAIN IS UNDER PAVEMENT, MANUAL AIR RELEASE VALVE ASSEMBLY IS TO BE INSTALLED REMOTE FROM TRANSMISSION MAIN AS DETERMINED IN THE FIELD BY THE ENGINEER BASED UPON THE CONDITIONS ENCOUNTERED.
  - EXPOSED PIPING, FITTINGS, AND VALVES IN ACCESS PIT TO BE WRAPPED WITH 1" THICK INSULATION.

**MANUAL AIR RELEASE VALVE ASSEMBLY**  
NO SCALE

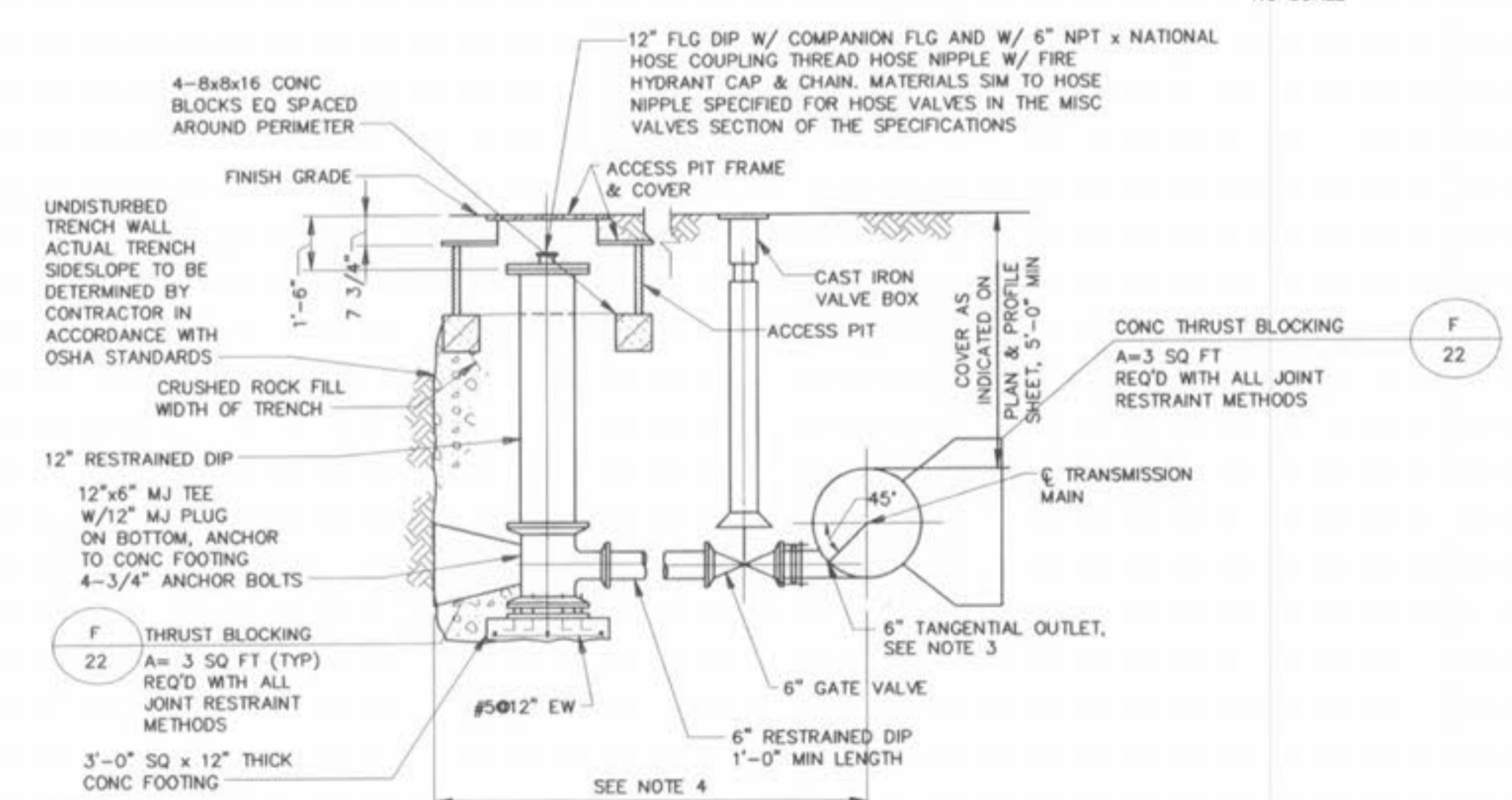

- NOTES:
- SEE PLAN & PROFILE SHEETS FOR APPROXIMATE LOCATION AND ORIENTATION OF BLOWOFF FACILITY. PRECISE LOCATION OF OUTLET, RISER PIPE, AND ACCESS PIT IS TO BE DETERMINED IN THE FIELD BY THE ENGINEER BASED UPON THE CONDITIONS ENCOUNTERED.
  - ALL JOINTS TO BE RESTRAINED.
  - AT THE OPTION OF THE CONTRACTOR, THE VALVE CONNECTION TO THE TANGENTIAL OUTLET MAY BE MADE BY ONE OF THE FOLLOWING METHODS: A) A TYTON JOINT GATE VALVE AND FIELD LOCK RESTRAINED PUSH-ON JOINT, B) A M.J. GATE VALVE AND GRIP RING PIPE RESTRAINER BY ROMAC INDUSTRIES, INC., C) A M.J. GATE VALVE AND A PLAIN END OUTLET WITH A WELDED GLAND AND ANCHORED COUPLING.
  - SEE PLAN FOR MAXIMUM DISTANCE FROM TRANSMISSION MAIN TO PERMANENT EASEMENT. IF BLOWOFF FACILITY CANNOT BE INSTALLED WITHIN THE MAXIMUM DISTANCE, ADD A 90° BEND AFTER THE VALVE AND INSTALL 6" PIPING PARALLEL TO THE TRANSMISSION MAIN.

**BLOWOFF FACILITY**  
NO SCALE

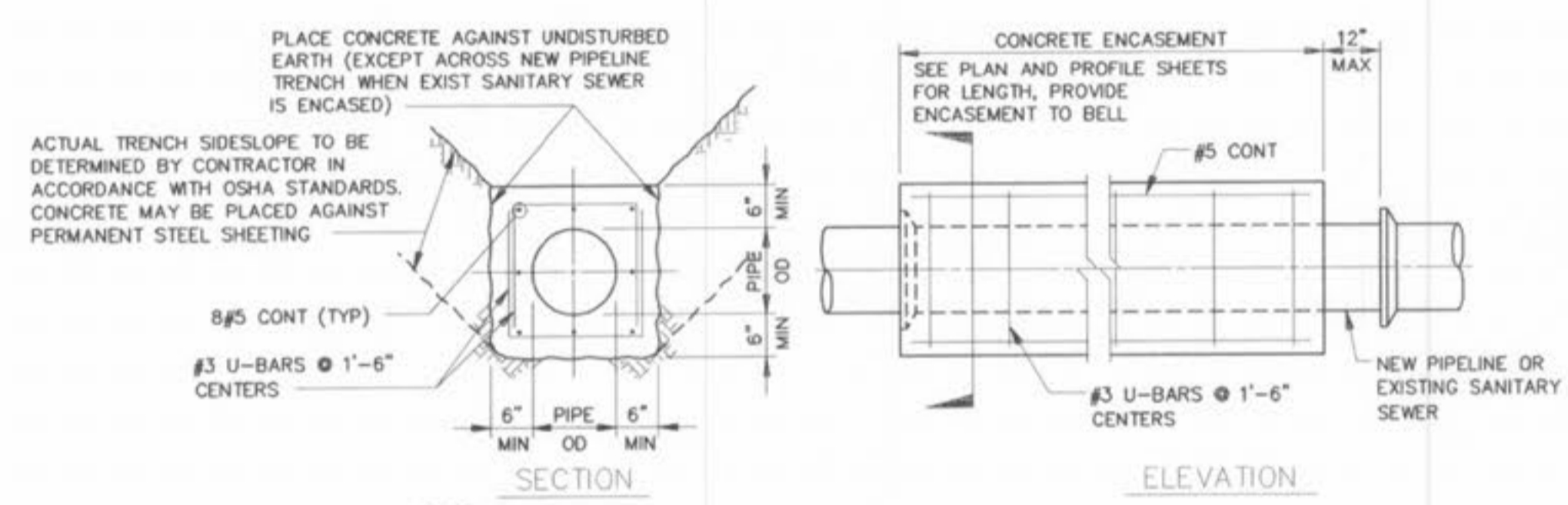

- NOTES:
- AT LOCATIONS WHERE THE TRANSMISSION MAIN CROSSES AN EXIST SANITARY SEWER, SEE SPECIFICATIONS FOR ADDITIONAL REQUIREMENTS.
  - WHEN THE PIPELINE IS PROTECTED WITH POLYETHYLENE TUBE ENCASUREMENT, THE CONCRETE ENCASUREMENT IS TO COVER THE POLYETHYLENE ENCASUREMENT.

**CONCRETE ENCASUREMENT**  
NO SCALE

**PICKETT RAY & SILVER**  
333 Mid Rivers Mall Drive  
St. Peters, MO 63376  
Phone (636) 397-1211  
Fax (636) 397-1104

**CIVIL ENGINEERS  
PLANNERS  
LAND SURVEYORS**

**VILLAS AT CRYSTAL RIDGE  
CONSTRUCTION DETAILS**

Prepared For:  
**SUMMIT POINTE L.C.**

239 FOX HILL ROAD  
ST. CHARLES, MO 63301  
(636) 940-9300

REVISIONS	NO.	DATE	REVISION PER CITY OF FALLON
1	1	07/11/03	

**ENGINEERS AUTHENTICATION**  
The responsibility for professional engineering liability on this project is hereby limited to the set of plans authenticated by the seal, signature, and date hereunder attached. Responsibility is disclaimed for all other engineering plans involved in this project and specifically excludes revisions after this date unless reauthenticating.

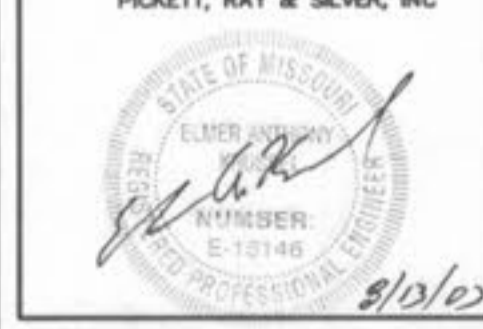

DRAWN	DATE
E.J.S.	04/09/03
CHECKED	DATE
D.W.D.	04/09/03

PROJECT # 01212 SUPP.02R  
TASK # 2 FIELD BOOK