

- NOTES:
1. STRAW BALES, NOT HAY BALES SHALL BE USED.
 2. BUTT ENDS OF BALES TIGHTLY TOGETHER.
 3. INSTALL BALES WITH BINDING AROUND SIDES, NOT TOP AND BOTTOM.
 4. FILL ANY GAP BETWEEN BALES BY WEDGING LOOSE STRAW BETWEEN THEM.

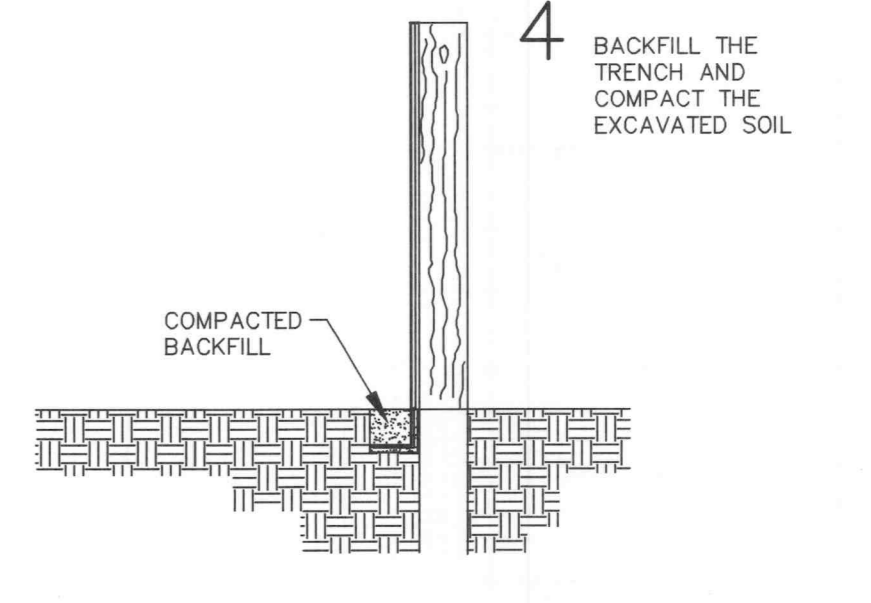

1. FILTER BARRIERS SHALL BE INSPECTED IMMEDIATELY AFTER EACH RAINFALL AND AT LEAST DAILY DURING PROLONGED RAINFALL. ANY REQUIRED REPAIRS SHALL BE MADE IMMEDIATELY.
2. SHOULD THE FABRIC DECOMPOSE OR BECOME INEFFECTIVE PRIOR TO THE END OF THE EXPECTED USABLE LIFE AND THE BARRIER STILL BE NECESSARY, THE FABRIC SHALL BE REPLACED PROMPTLY.
3. SEDIMENT DEPOSITS SHOULD BE REMOVED AFTER EACH STORM EVENT. THEY MUST BE REMOVED WHEN DEPOSITS REACH APPROXIMATELY HALF THE HEIGHT OF THE BARRIER.
4. ANY SEDIMENT DEPOSITS REMAINING IN PLACE AFTER THE SILT FENCE OR FILTER BARRIER IS NO LONGER REQUIRED SHALL BE DRESSED TO CONFORM WITH THE EXISTING GRADE, PREPARED AND SEEDED.

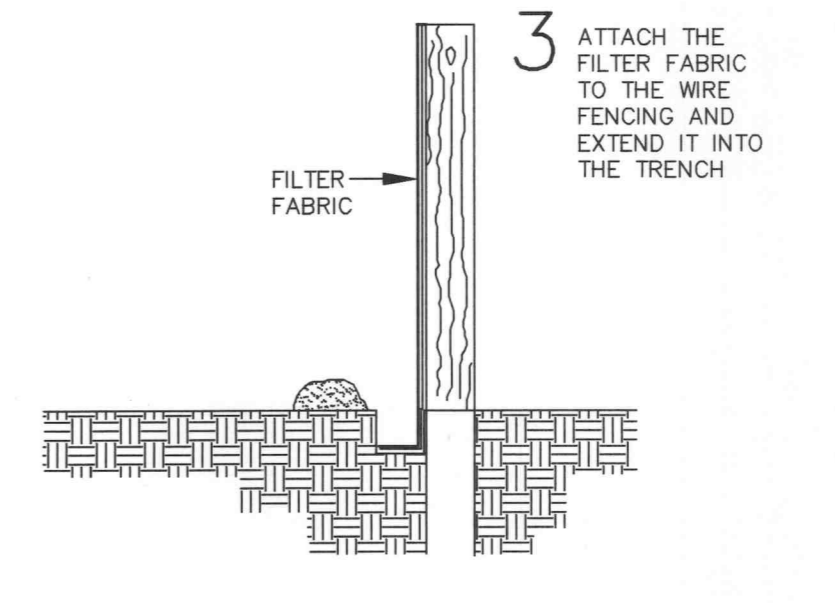
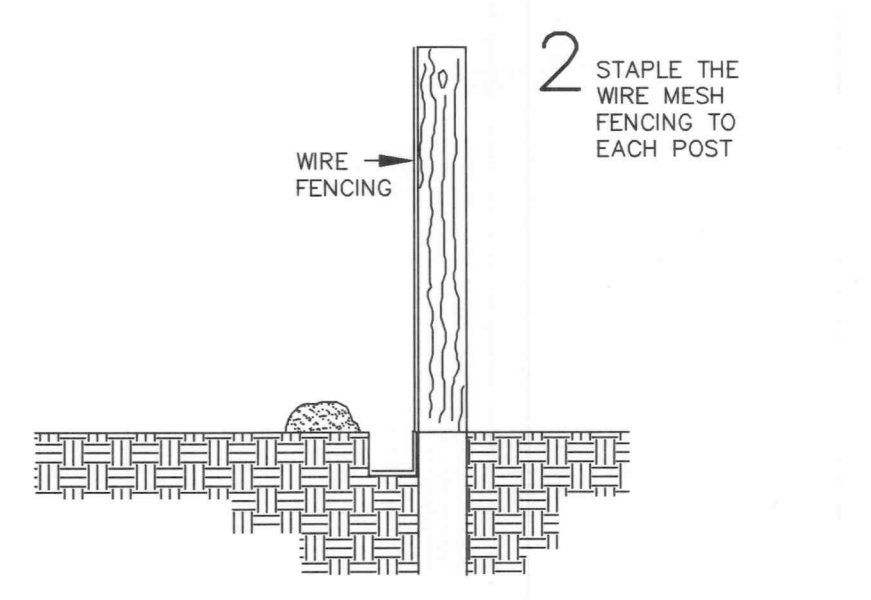
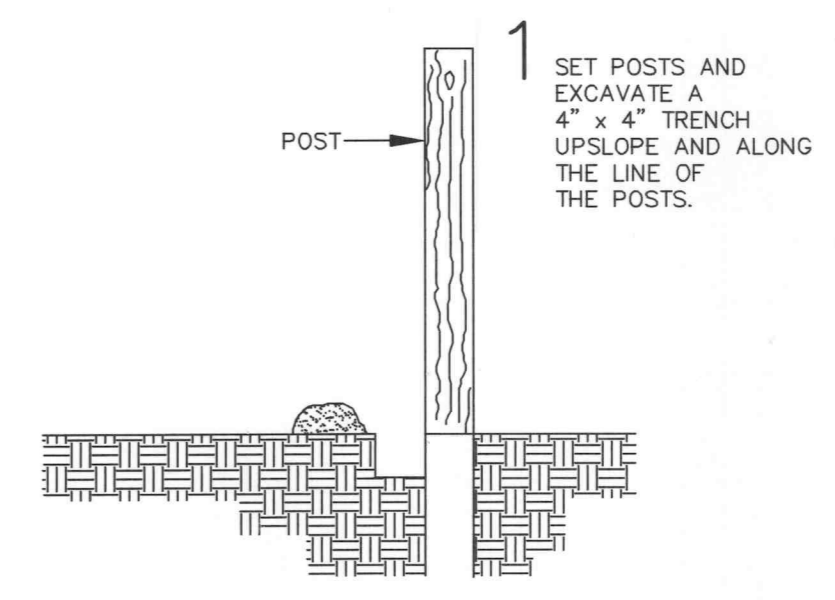
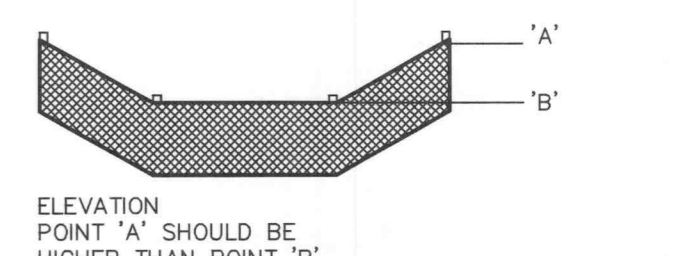
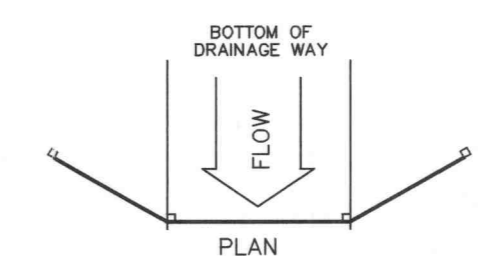

SILTATION FENCE DETAIL

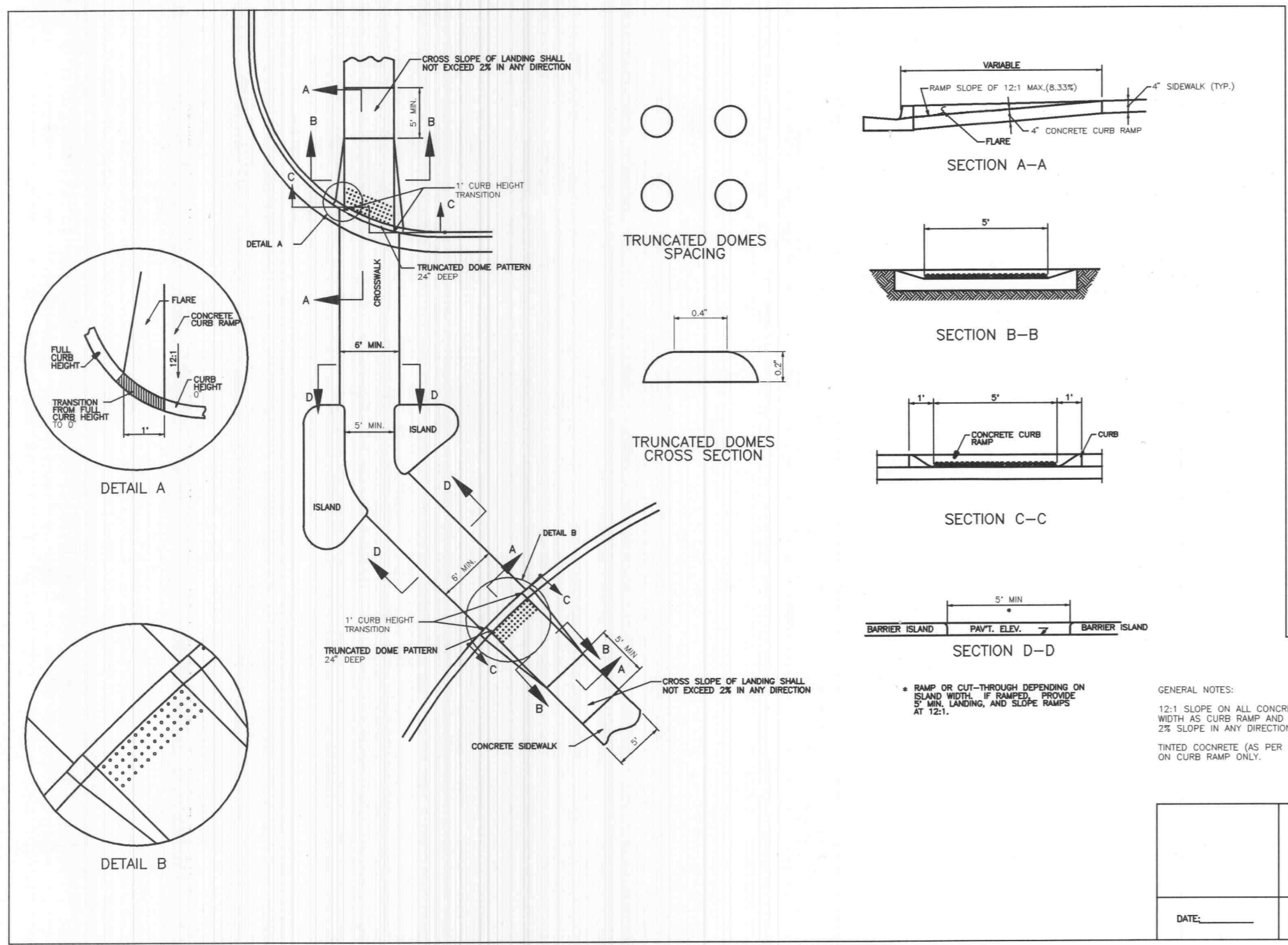
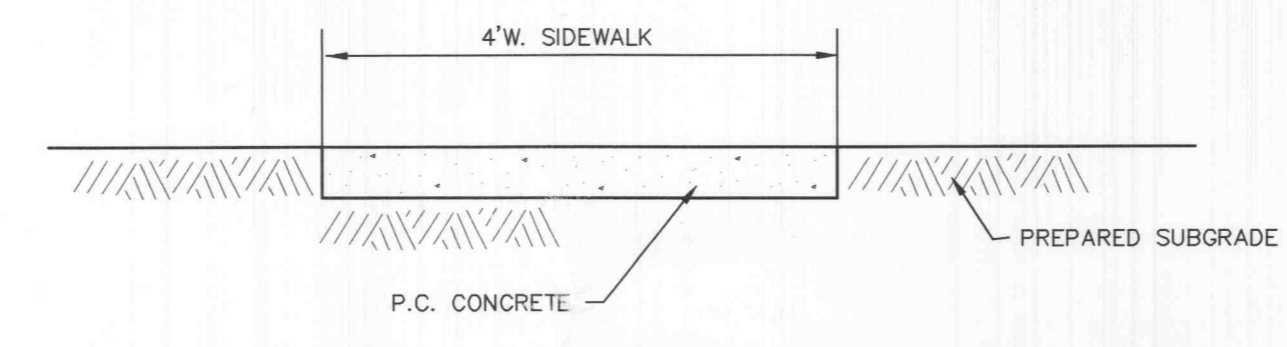
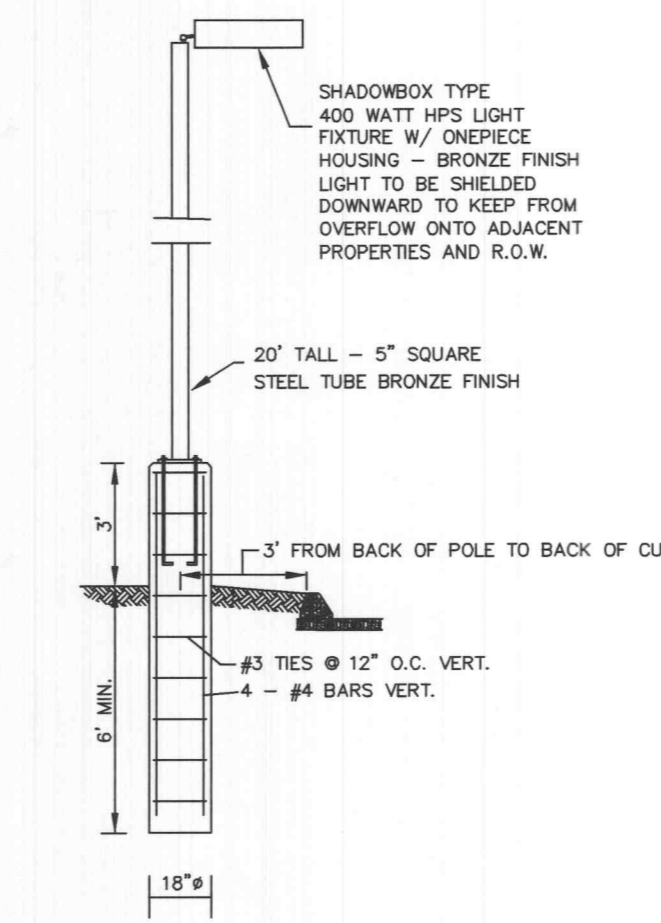
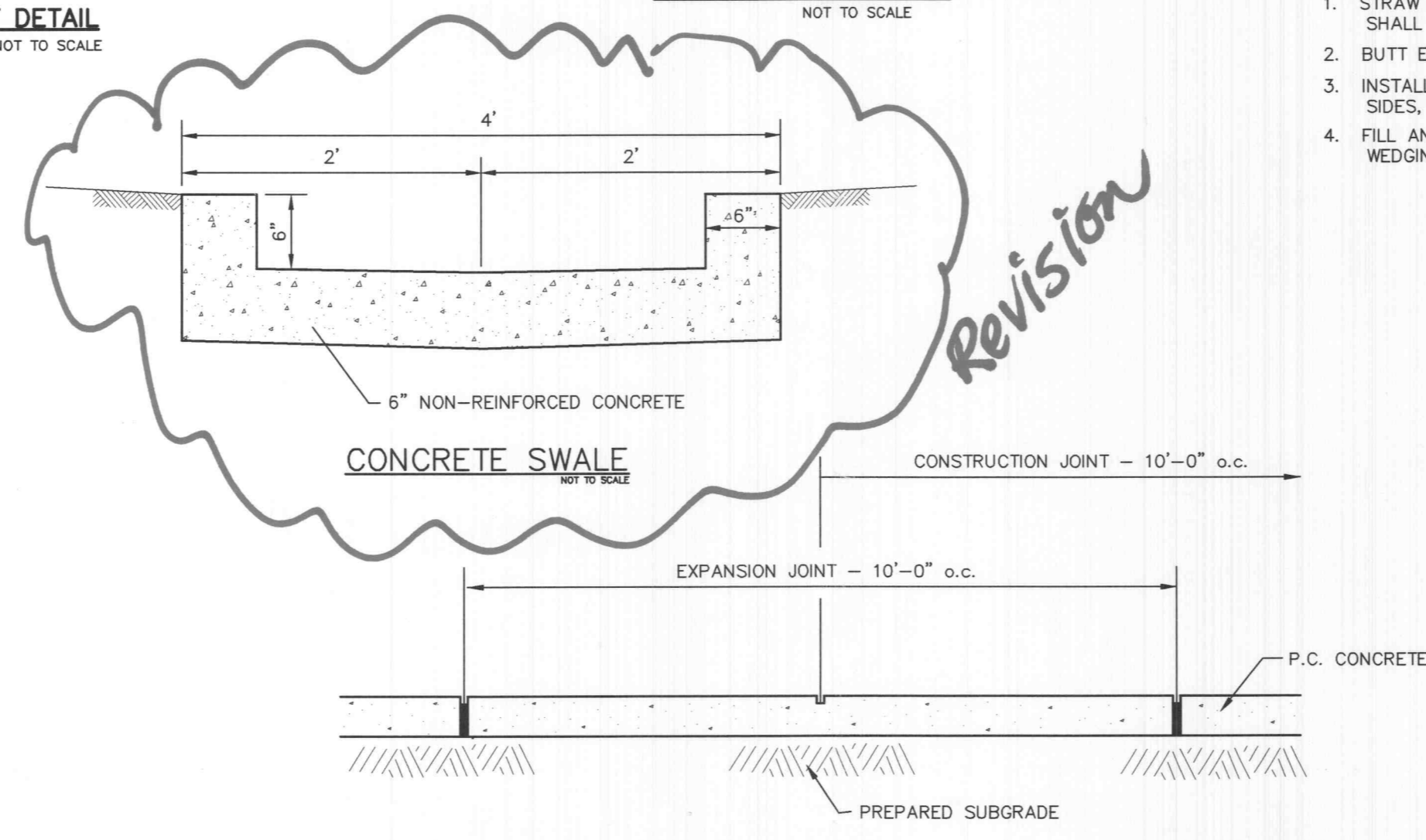
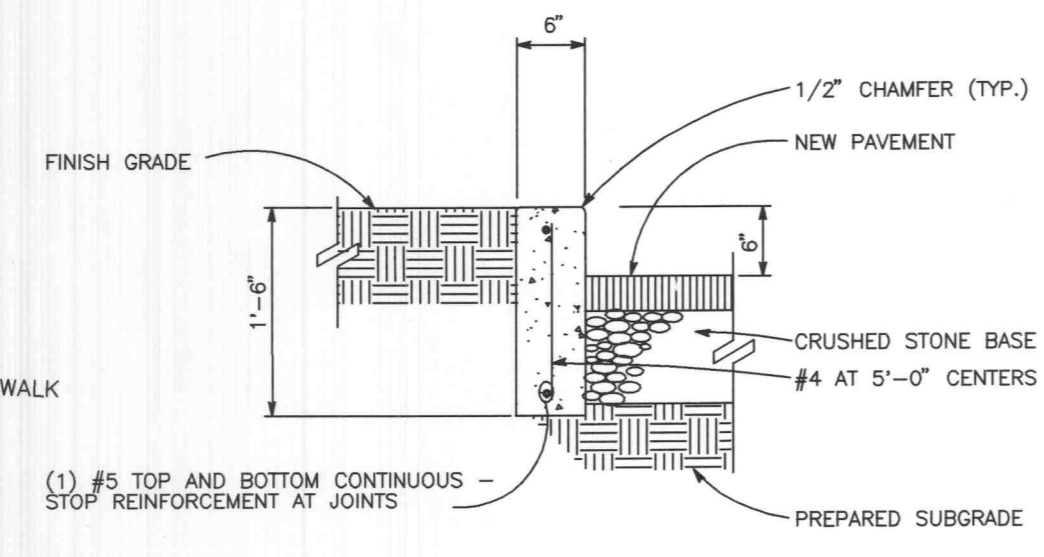
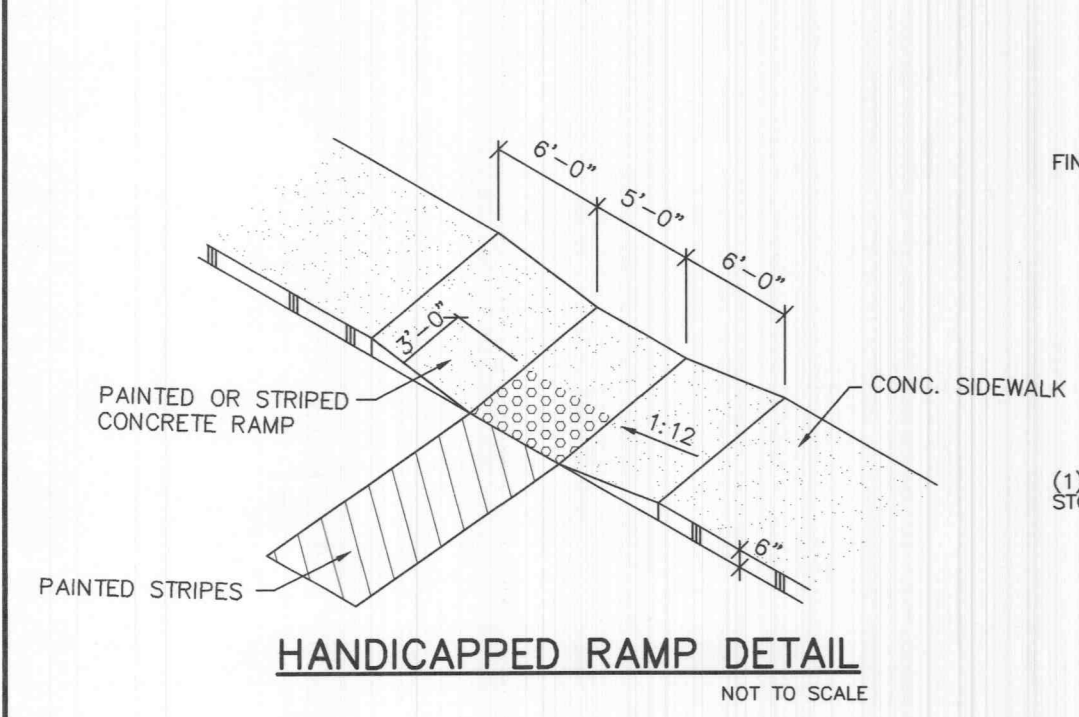

CONCRETE SIDEWALK DETAIL

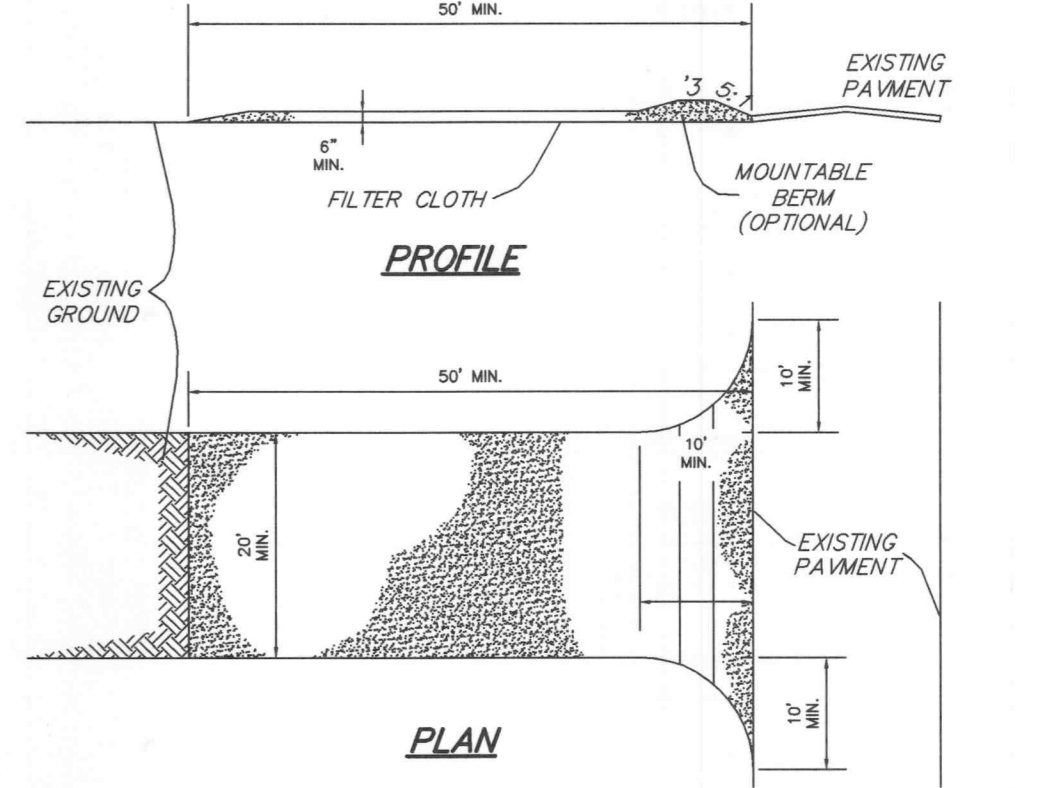
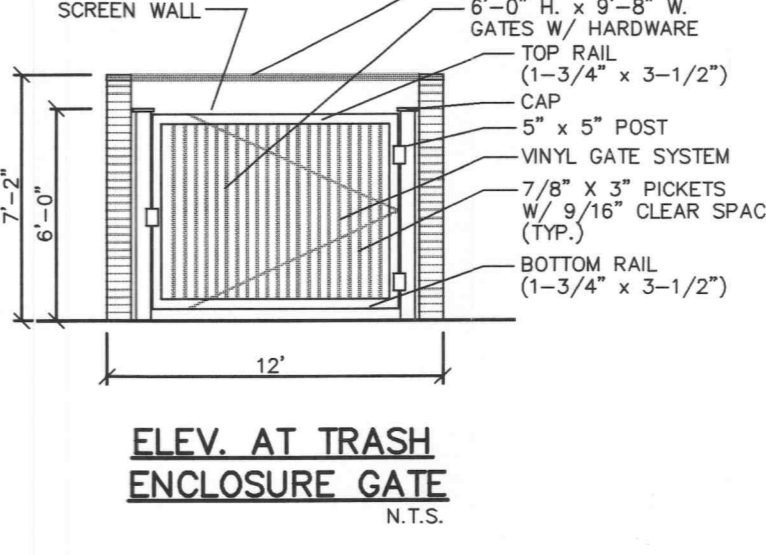
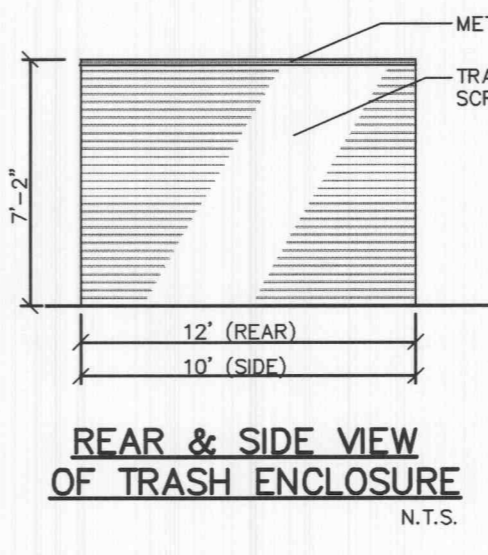
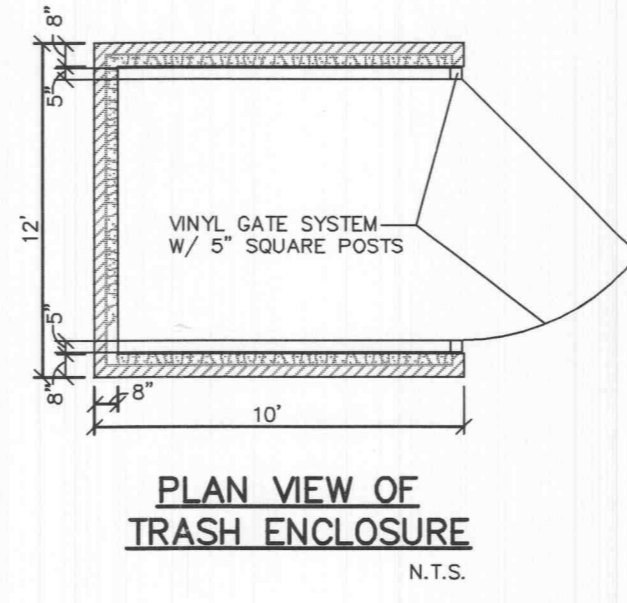

CONSTRUCTION SPECIFICATIONS

1. Stone Size - Use 2" stone, or reclaimed or recycled concrete equivalent.
2. Length - As required, but not less than 50 feet (except on a single residence lot where a 30 foot minimum length would apply).
3. Thickness - Not less than six (6) inches.
4. Width - Twenty (20) foot minimum, but not less than the full width at points where ingress or egress occurs.
5. Filter Cloth - Will be placed over the entire area prior to placing of stone. Filter will not be required on a single family residence lot.
6. Surface Water - All surface water flowing or diverted toward construction entrances shall be piped across the entrance. If piping is impractical, a mountable berm with 5:1 slopes will be permitted.
7. Maintenance - The entrance shall be maintained in a condition which will prevent tracking or flowing of sediment onto public rights-of-way. This may require periodic top dressing with additional stone as conditions demand and repair and/or cleanup of any measures used to trap sediment. All sediment spilled, dropped, washed or tracked onto public rights-of-way must be removed immediately.
8. Washing - Wheels shall be cleaned to remove sediment prior to entrance onto public rights-of-way. When washing is required, it shall be done on an area stabilized with stone and which drains into an approved sediment trapping device.
9. Periodic inspection and needed maintenance shall be provided after each rain.

STABILIZED CONSTRUCTION ENTRANCE/WASHDOWN AREA
NOT TO SCALE

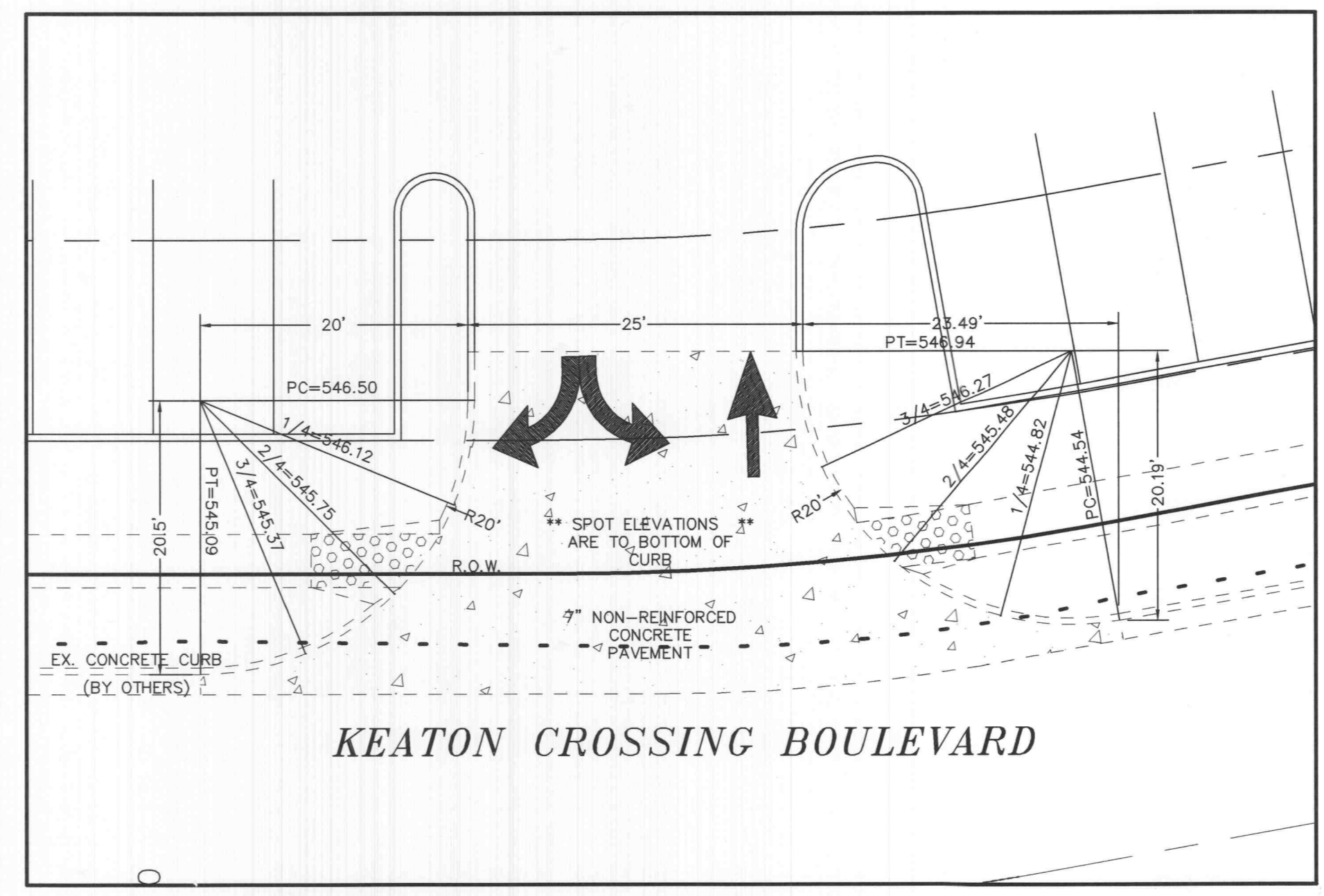

ENTRANCE DETAIL

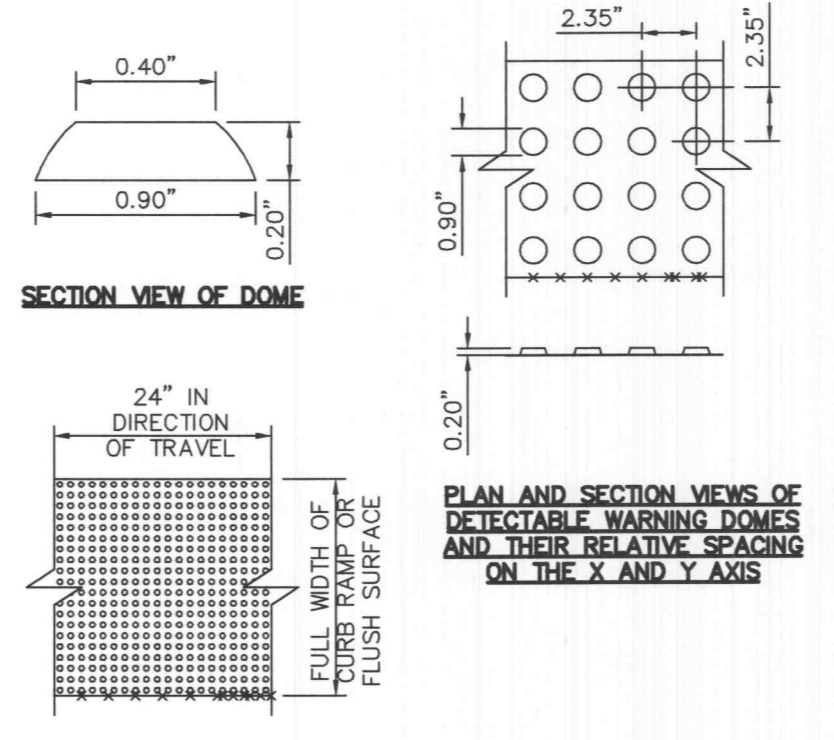

PLAN VIEW OF A DETECTABLE WARNING SURFACE SHOWING DOMES ALIGNED IN ROWS, NOT SKEWED DIAGONALLY.
TYPICAL DETAIL OF DETECTABLE WARNING SURFACE
NOT TO SCALE

