

**TYPICAL SECTION WALL A**  
NOT TO SCALE

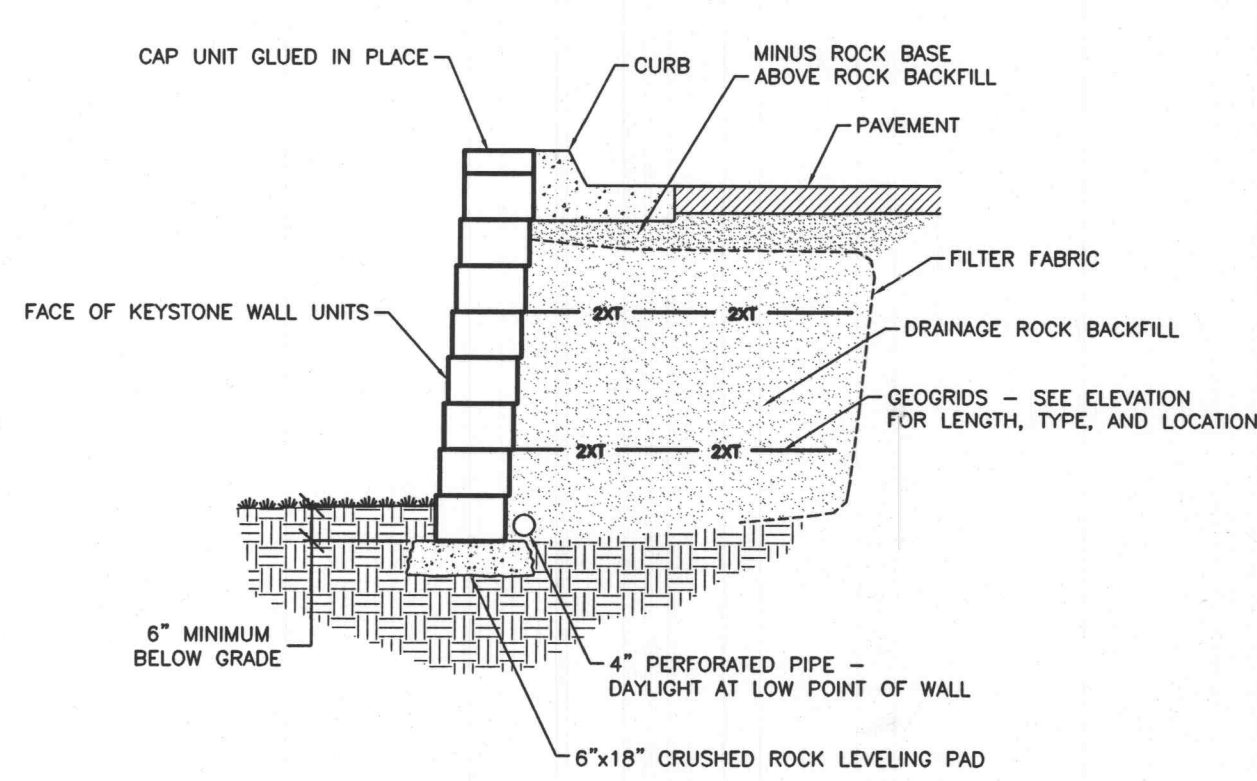

**TYPICAL SECTION WALL B & C**  
NOT TO SCALE

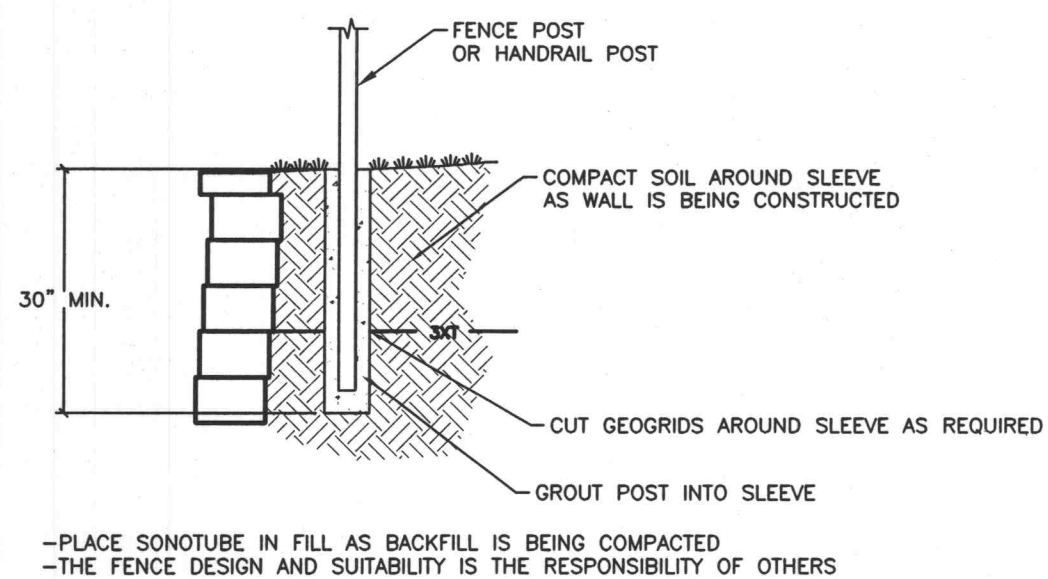

**FENCE DETAIL**  
NOT TO SCALE

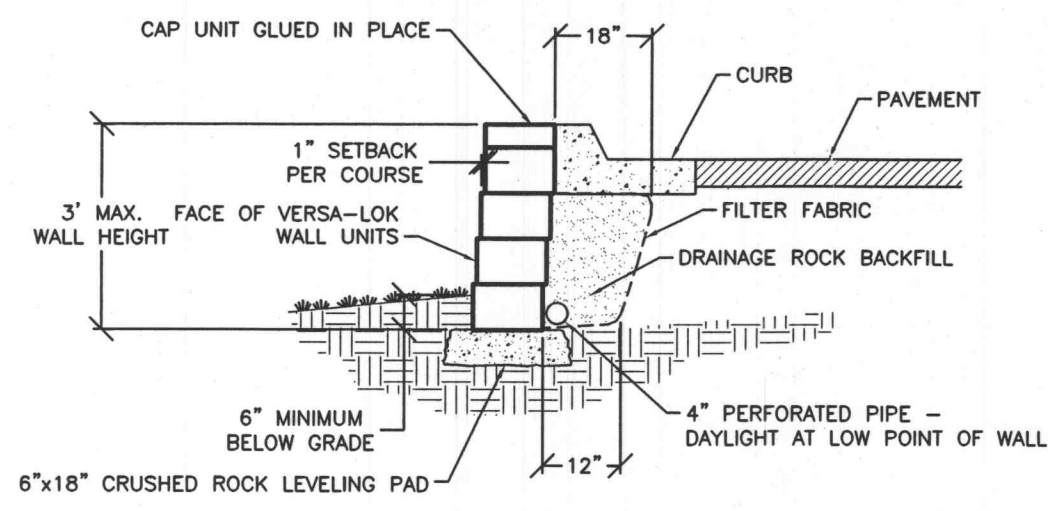

**UNREINFORCED SECTION**  
NOT TO SCALE

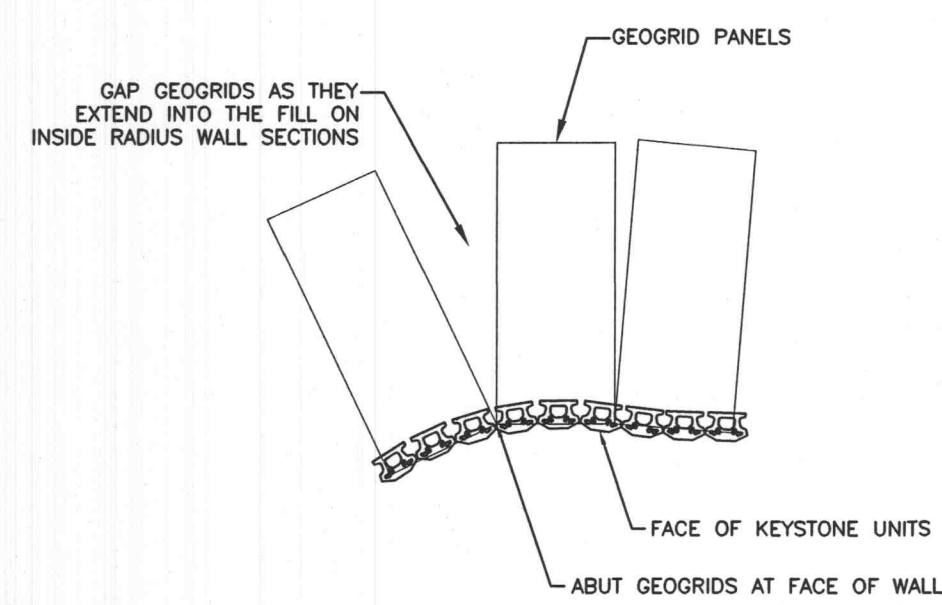

**INSIDE RADIUS DETAIL**  
NOT TO SCALE

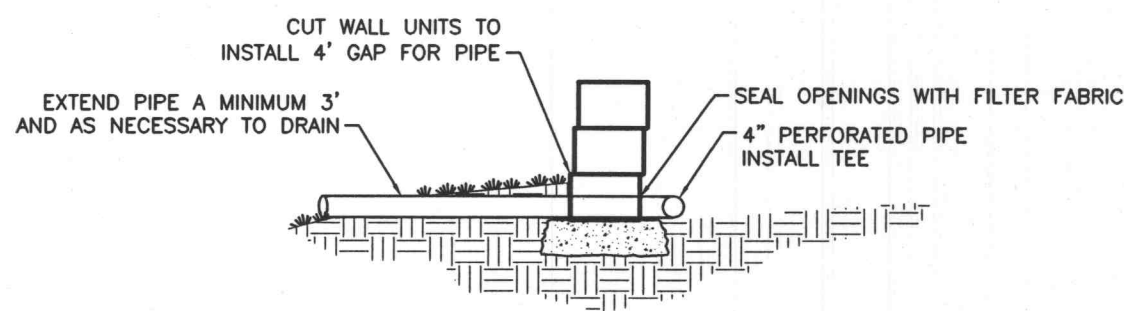

**PERFORATED PIPE OUTLET**  
NOT TO SCALE

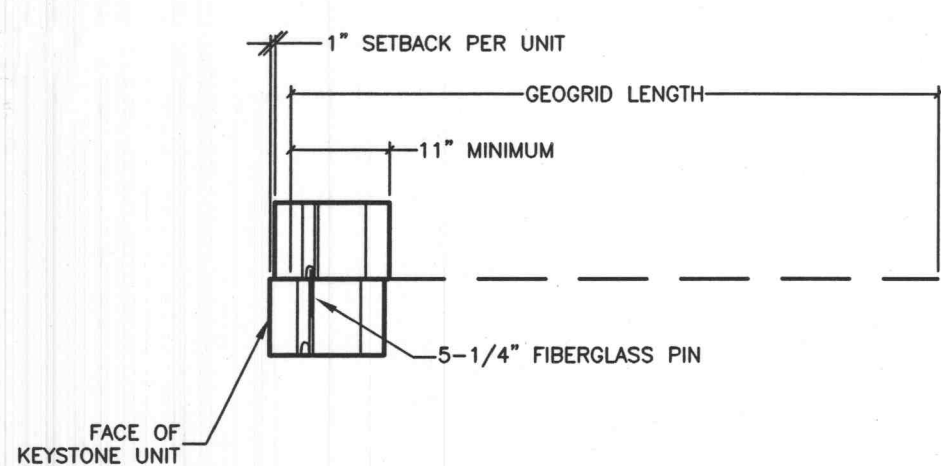

**CONNECTION DETAIL**  
NOT TO SCALE

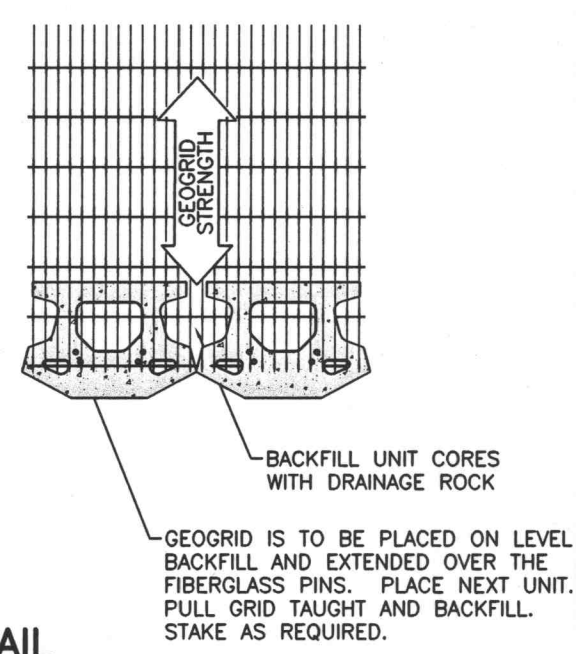

**COMPAC II UNIT**  
NOT TO SCALE

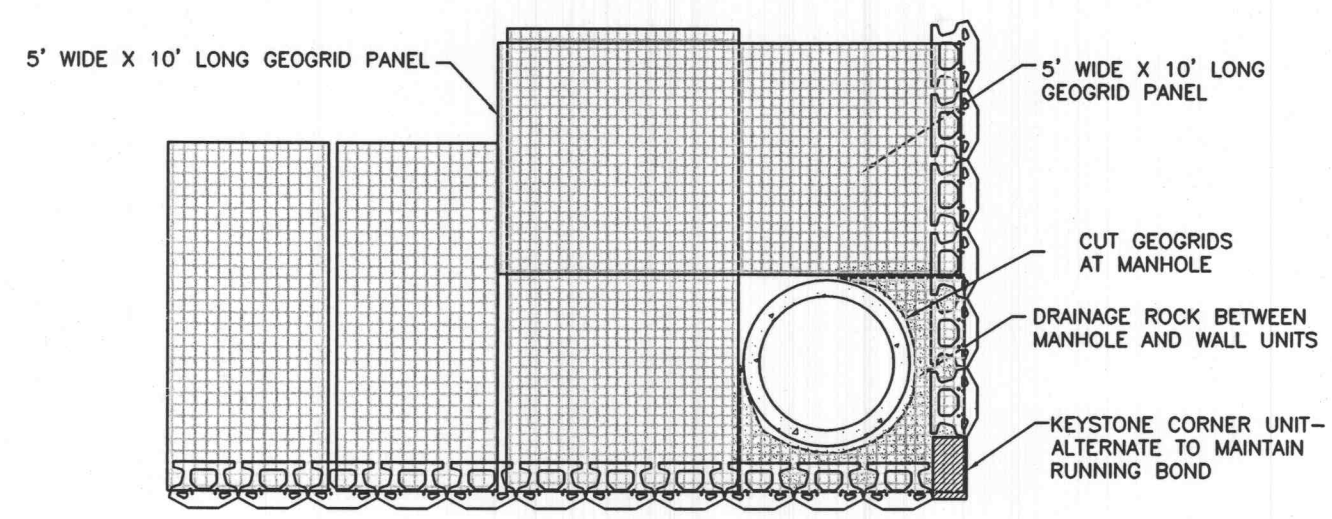

**MANHOLE DETAIL**  
NOT TO SCALE

**SPECIFICATIONS FOR RETAINING WALL - Del Taco**

**MATERIALS**

Retaining wall units shall be Keystone Compac II block units as manufactured by Kirchner Block & Brick. The units are 18" wide x 8" tall x 12" deep with a split face finish. The color shall be chosen by the owner. Concrete wall units shall meet the requirements of ASTM C1372 except compressive strength shall be a minimum 3000 psi and the maximum water absorption shall be limited to 8.0 percent. The concrete shall have adequate freeze thaw resistance in accordance with ASTM C1262.

The reinforced wall backfill material shall be compacted rock. The rock shall be crushed limestone with a maximum 1" particle size and a maximum of 5% passing the #200 sieve, similar to 1" clean gradation.

The geogrids shall be Miragrid 2XT geogrid as indicated on the plans and as manufactured by TC Mirafi Group. The geotextile filter fabric shall be Mirafi 140NL.

The leveling pad shall be constructed of crushed limestone similar to 1" or 2" minus rock gradation.

The drainage pipe shall be 4" HDPE tubing.

**WALL FOUNDATION**

Foundation soil shall be excavated as required for the leveling pad and the reinforced fill zone to the depths and locations shown on the plan sheet or as directed by the site engineer. The exposed foundation soil shall be observed by a qualified technician, engineer, or owner's representative prior to construction to verify that the exposed material is suitable for a net allowable bearing pressure of 2000 psf (with a factor of safety of 2.0), and that the base of the excavation is free of loose soil, shale, high plastic clays, uncompacted fill, water, or frozen material. Undercut any unsuitable soil. Undercut areas shall be filled with crushed limestone and compacted to at least 95% of the material's standard Proctor maximum dry density.

The foundation shall be proof rolled with 2 passes of a vibratory compactor prior to beginning retaining wall construction.

Construct the crushed rock leveling pad to lines and grades shown on the plans. The leveling pad shall be compacted in a maximum 6" lifts with 3 passes of a vibratory compactor.

**WALL CONSTRUCTION**

Install the first course of units on the leveling pad. Place the fiberglass pins in the first unit then install the next course in a running bond stack. Units may need to be cut around radius corners to maintain the bond pattern. Pull unit forward. Use 2 pins per unit. Backfill units and cores with drainage rock, backfill the reinforced zone, and continue construction.

Install drainage rock in unit cores and extending to the end of the geogrids.

Cop units shall be glued in place at the top of the wall.

**GEOGRID REINFORCING**

The geogrids shall be cut to design lengths and placed between the blocks at the elevations shown on the plans. The geogrid's primary strength direction will be directed perpendicular to the wall face (into the fill.) The geogrids placed outside a plus or minus 4" zone of the geogrid design elevation will not be accepted. The geogrid shall be placed horizontally and lay flat on the reinforced fill soil. The geogrid shall have a minimum of 11" of grid between the block layers. Slack in the geogrid shall be removed prior to placing additional backfill. The geogrids shall be installed in one continuous piece with no joints in the strength direction. The geogrids shall be placed side-by-side along the wall alignment with no overlap required.

**WALL BACKFILL**

Backfill shall be placed, spread, and compacted in such a manner that minimizes wrinkles and movement of the geogrid. Wall backfill material shall be placed in maximum 10" loose lifts and compacted to at least 95% of the material's maximum dry density as determined by the standard Proctor method (ASTM D698.) Testing methods, frequency, and verification of material specifications shall be the responsibility of the owner or the owner's representative. The drainage rock shall be compacted with a minimum 2 passes of a vibratory compactor and field density testing will not be required for the drainage rock. During backfill placement the 3 foot zone directly behind the wall shall be limited to the use of hand operated compaction equipment only.

Construction equipment shall not be directed directly on the geogrid.

**CURB**

The curb above the wall may be installed against the back of the wall units. The geogrid layers are not to be cut during curb installation. Care shall be taken in the installation of the curb so as to not move the wall.

**SCOPE OF THIS RETAINING WALL DESIGN**

The retaining wall design includes a complete analysis of the internal stability of the retaining wall system and an external design analysis of the system's resistance to sliding and overturning in accordance with the NEMA and/or AASHTO Section 5 guidelines. These retaining wall plans provide the bearing pressures that the wall exerts on the foundation soils. The owner or owner's representative shall verify that the foundation soils at the retaining wall location will provide the necessary bearing capacity to support the wall system. The global stability of the entire site, as well as at the retaining wall location, is outside the scope of the retaining wall design.

The erosion protection of the soil at the face of the wall and at the top of the wall is beyond the scope of this design. Design of pipes, manholes, light standards, signs, guard rails, fences, curbs, and other materials around the retaining wall are beyond the scope of this design. Details on our plans that show any of these items are intended only for the wall contractor to know how to construct the retaining wall at these structures.

The contractor is strictly responsible for the construction means, methods, techniques, sequences or procedures, and the safety precautions and programs connected with the work.

**PROTECTION OF WORK**

The surface of the wall backfill shall be graded at the end of each day of work to provide positive surface drainage away from the wall. Grading shall include proper contouring of soils in adjacent areas to prevent the flow of surface water into the reinforced earth zone and to prevent to flow of surface water along the front face of the wall.

The design of the walls is based on conditions and loads imposed on the wall at completion of the project. Prior to project completion, the wall is vulnerable to damages caused by construction activity adjacent to the wall. Of particular concern is the use of grading and pavement construction equipment on the reinforced backfill at the top of the wall. Only equipment with a weight not exceeding one ton can be used in the 3 foot zone directly behind the back of the wall face.

Prior to the wall construction exceeding 5' in height the soil at the face of the wall shall be placed and compacted to the final grades. There shall be a minimum 2' wide flat area at the face of the wall and the soil shall slope away from the wall.

No changes shall be made to these plans without the written approval of Aspen Consultants.

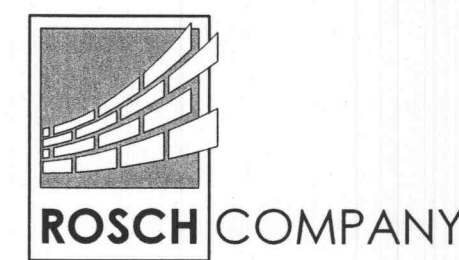

293 Northwest Blvd., Fenton, MO 63026  
Phone: (636) 349-2225 Fax: (636) 349-2230

**DEL TACO**  
O'Fallon, MO

**KEYSTONE WALL** | **DETAILS AND SPECS**

Revision: 8-17-2005, New wall layouts | Date: 7-22-2005  
Revision: | Sheet: 3 of 3