

St Charles County Government		WVAULTSERVER\Folders\90009203V - Dollar General - Crossing Industrial Lot 4\Engineering\Hydraulics\9203V.txt																								
Hydraulic Review Output Data		12/20/2022																								
Upp Str	Low Str	PL	S	Upp FL LN	Low FL LN	PS	Upp ST EL	Depth HY GR	Upp HY EL	Low HY EL	Hydr Grade	FR Head	VEL	VEL Head	Junc Loss	Turn Loss	Curve Loss	STR Grade	Inl Cap	DR Area	P.I.	Q	TQ	Pipe Cap	Remarks	
1	GH106	MH105	108	12	503.51	502.43	1.00	507.55	3.68	503.87	503.47	0.00080	0.09	1.26	0.02	0.02	0.00	0.00						0.99	3.56	
2	MH105	CH104	135	12	502.23	500.88	1.00	509.65	6.18	503.47	503.35	0.00080	0.11	1.26	0.02	0.00	0.01	0.00						0.99	3.56	
3	CH104	EP103	9	12	500.68	500.59	1.02	508.70	5.35	503.35	503.28	0.00760	0.07	3.96	0.24	0.00	0.00	0.00						3.11	3.60	15YR HW=503.28
4	OS102	MH101	14	12	490.87	490.73	0.97	504.20	12.09	492.11	491.73	0.00820	0.12	4.11	0.26	0.26	0.00	0.00						3.23	3.51	
5	MH101	FE100	163	12	490.63	489.00	1.00	503.00	11.49	491.51	490.00	0.00820	1.33	4.11	0.26	0.00	0.18	0.00						3.23	3.56	ITP=490.00

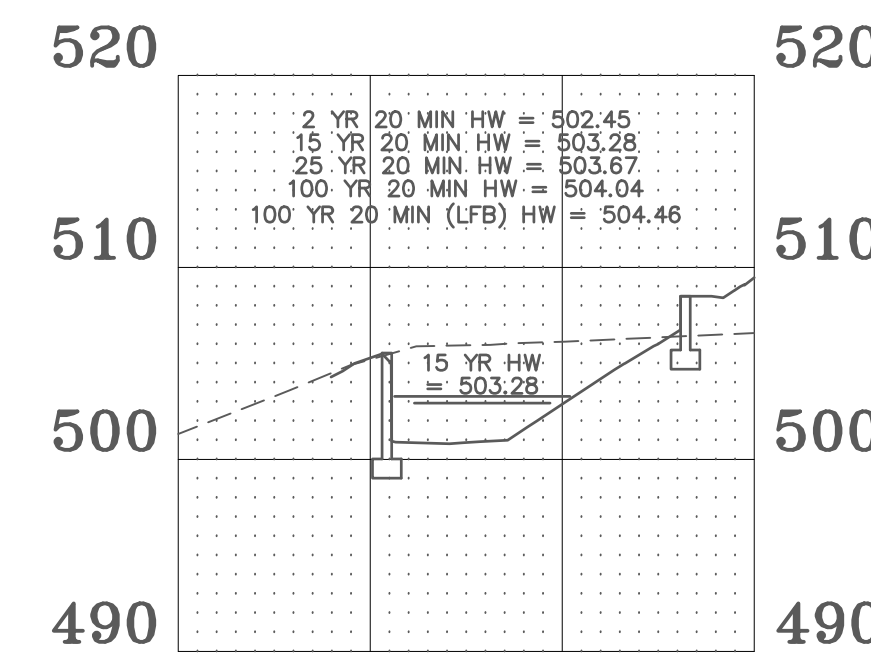

PROJECT TITLE:
CONSTRUCTION PLANS FOR
Dollar General
395 TR Hughes Boulevard
O'Fallon, MO 63366

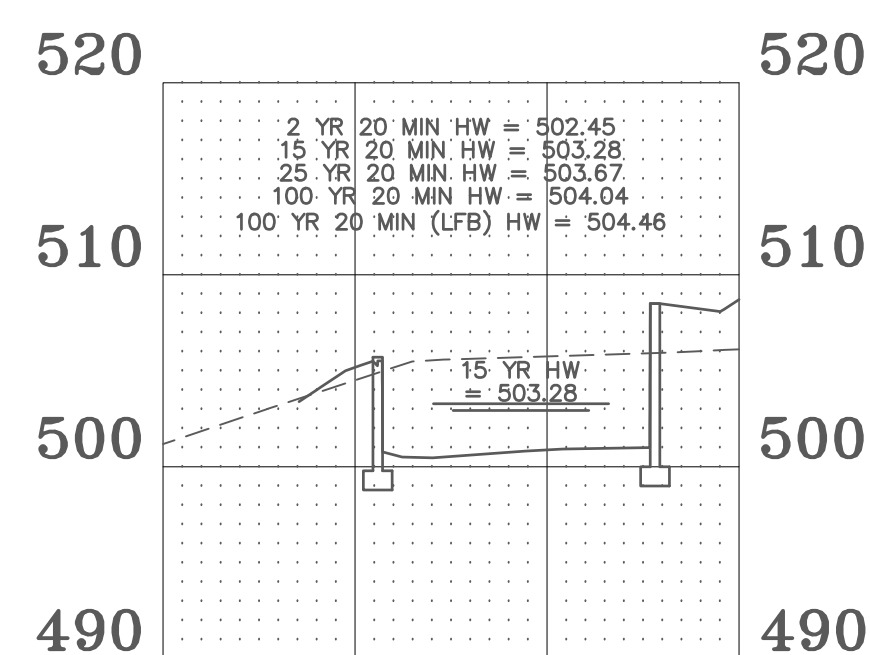
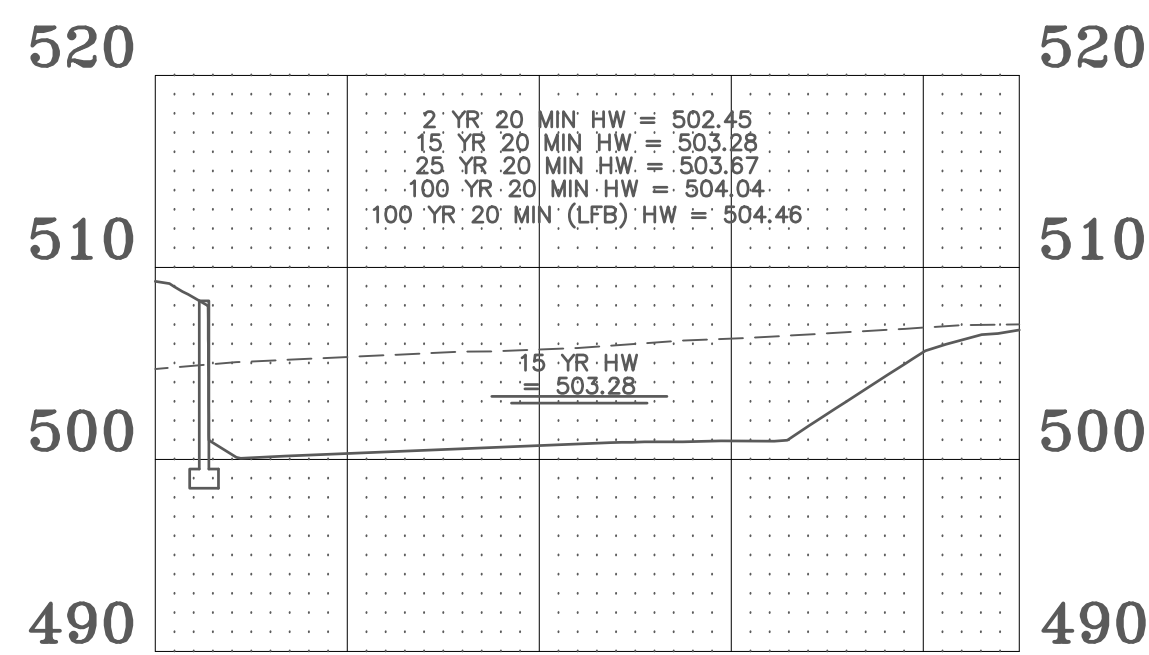

STATE OF MISSOURI
 PROFESSIONAL ENGINEER
 NUMBER 071123
 JERRY D. WALKER
 Civil Engineer
 2007/02/05/53
 Copyright © 2022
 DGS Engineering Company, Inc.
 Authority No. 000655
 All Rights Reserved

REVISIONS	
12-21-22	CITY COMMENTS
01-04-23	CITY COMMENTS
01-06-23	CITY COMMENTS
05-03-23	DG REVISIONS
05-17-23	CITY COMMENTS
07-11-23	4' HIGH FENCE

Developer / Owner:
DG Partners L.L.C.
5330 Salt River Road
St. Peters, MO 63376
(636) 970-0330

STORM SEWER PROFILES

P+Z No. 22-009150
Approved: 10-06-22
City No. #

Page No.
 12 of 16



CALL BEFORE YOU DIG!
 1-800-DIG-RITE

UNDERGROUND UTILITIES HAVE BEEN PLOTTED FROM AVAILABLE INFORMATION AND THEREFORE THEIR LOCATIONS SHALL BE CONSIDERED APPROXIMATE ONLY. THE VERIFICATION OF THE LOCATION OF ALL UNDERGROUND UTILITIES, EITHER SHOWN OR NOT SHOWN ON THESE PLANS SHALL BE THE RESPONSIBILITY OF THE CONTRACTOR, AND SHALL BE LOCATED PRIOR TO ANY GRADING OR CONSTRUCTION OF THE IMPROVEMENTS.