

NOTE: THIS DETAIL IS FROM PWS#2

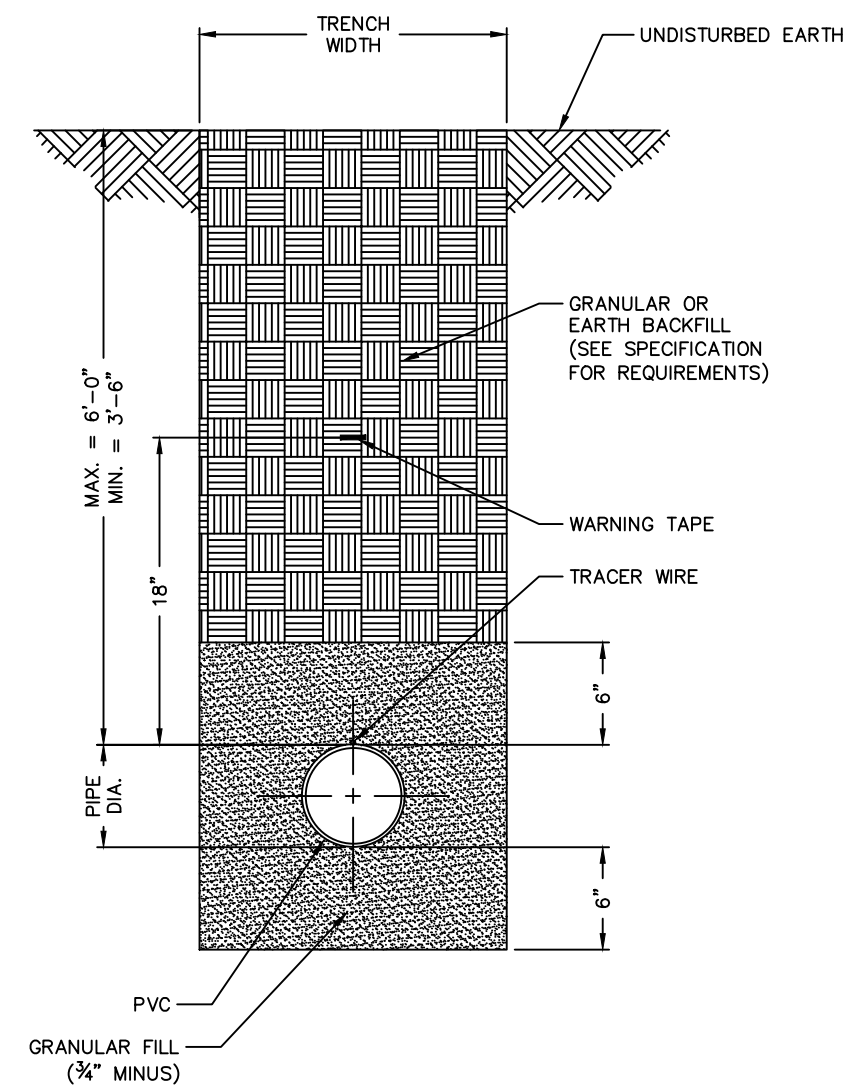

NOTES

- SEE SPECIFICATIONS FOR ADDITIONAL DETAILS FOR BEDDING AND BACKFILL.

TYPICAL TRENCH SECTION FOR PVC PIPE
NOT TO SCALE
DETAIL "A"
PAGE 1 OF 2

NOTE: THIS DETAIL IS FROM PWS#2

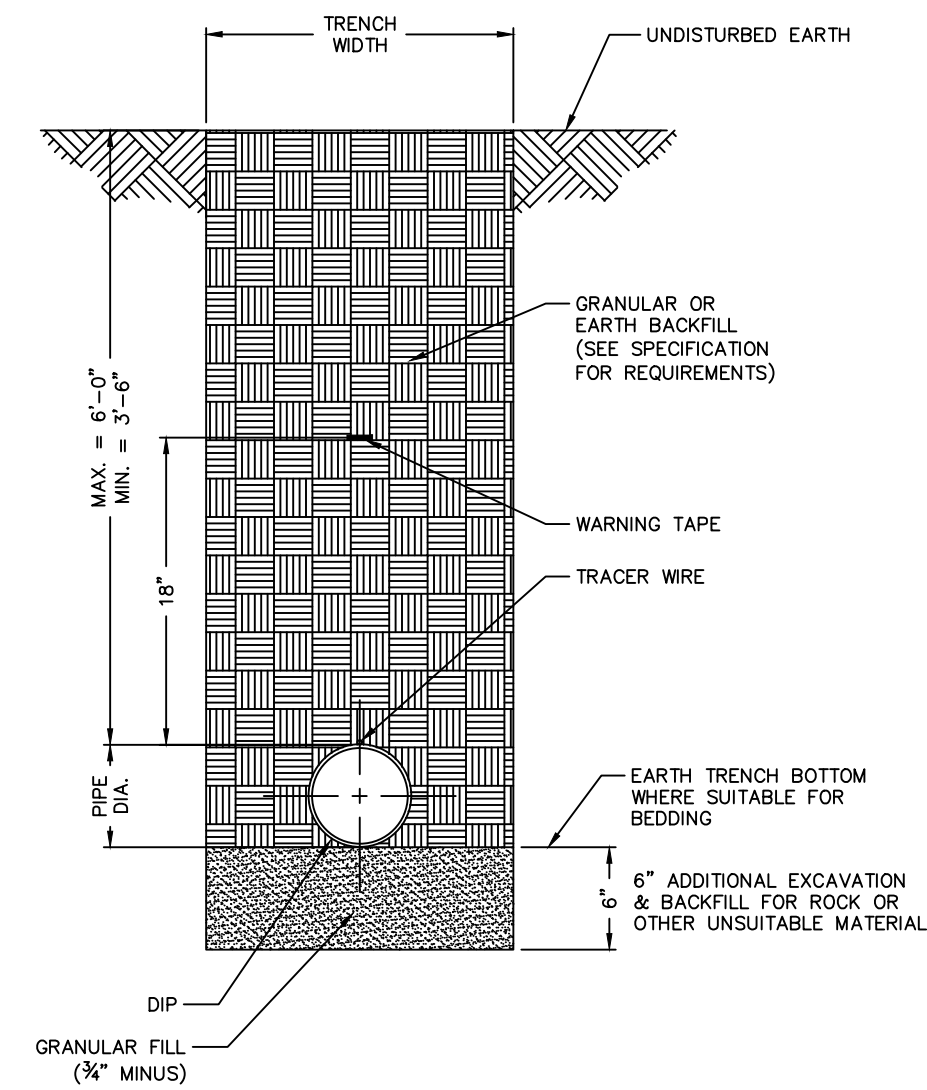

NOTES

- POLYWRAP REQUIRED FOR DUCTILE IRON PIPE
- SEE SPECIFICATIONS FOR ADDITIONAL DETAILS FOR BEDDING AND BACKFILL.

TYPICAL TRENCH SECTION FOR DUCTILE IRON PIPE
NOT TO SCALE
DETAIL "A"
PAGE 2 OF 2

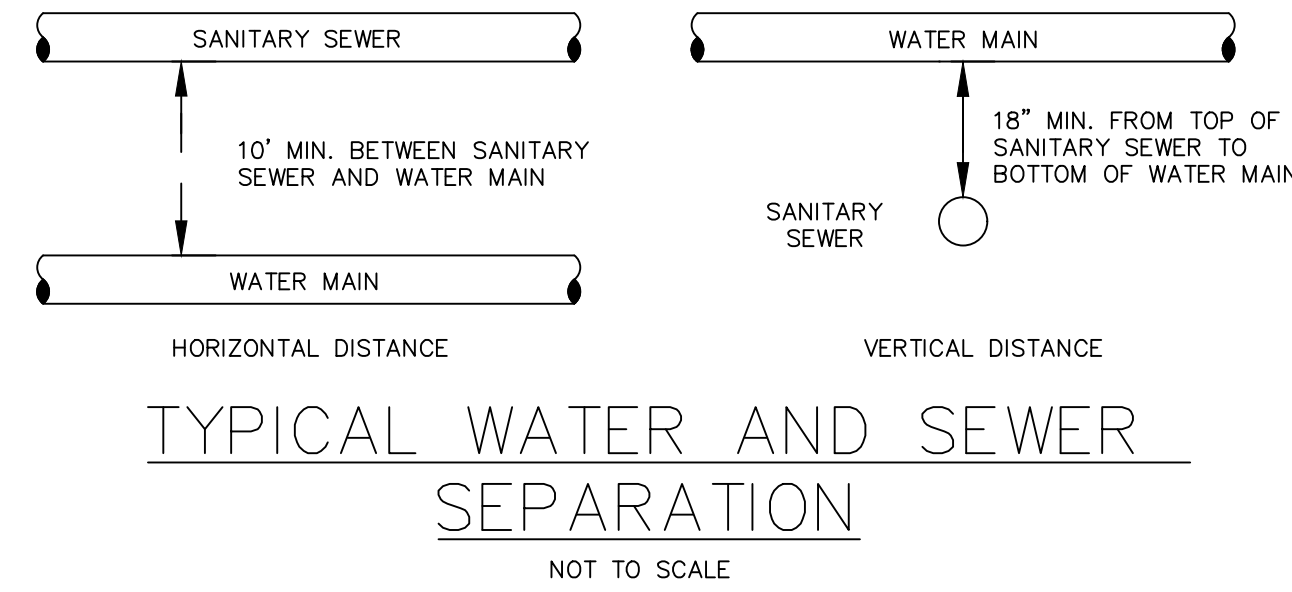

CITY OF O'FALLON
ENGINEERING DEPARTMENT
O'FALLON, MISSOURI
WATER AND SEWER SEPARATION DETAIL

Ductile Iron Pipe installation shall follow the Ductile Iron Research Association (DIPRA) guide line.
The Installation of PVC Pipe shall follow the Uni-Bell PVC Pipe Association Handbook of PVC Design and Construction.

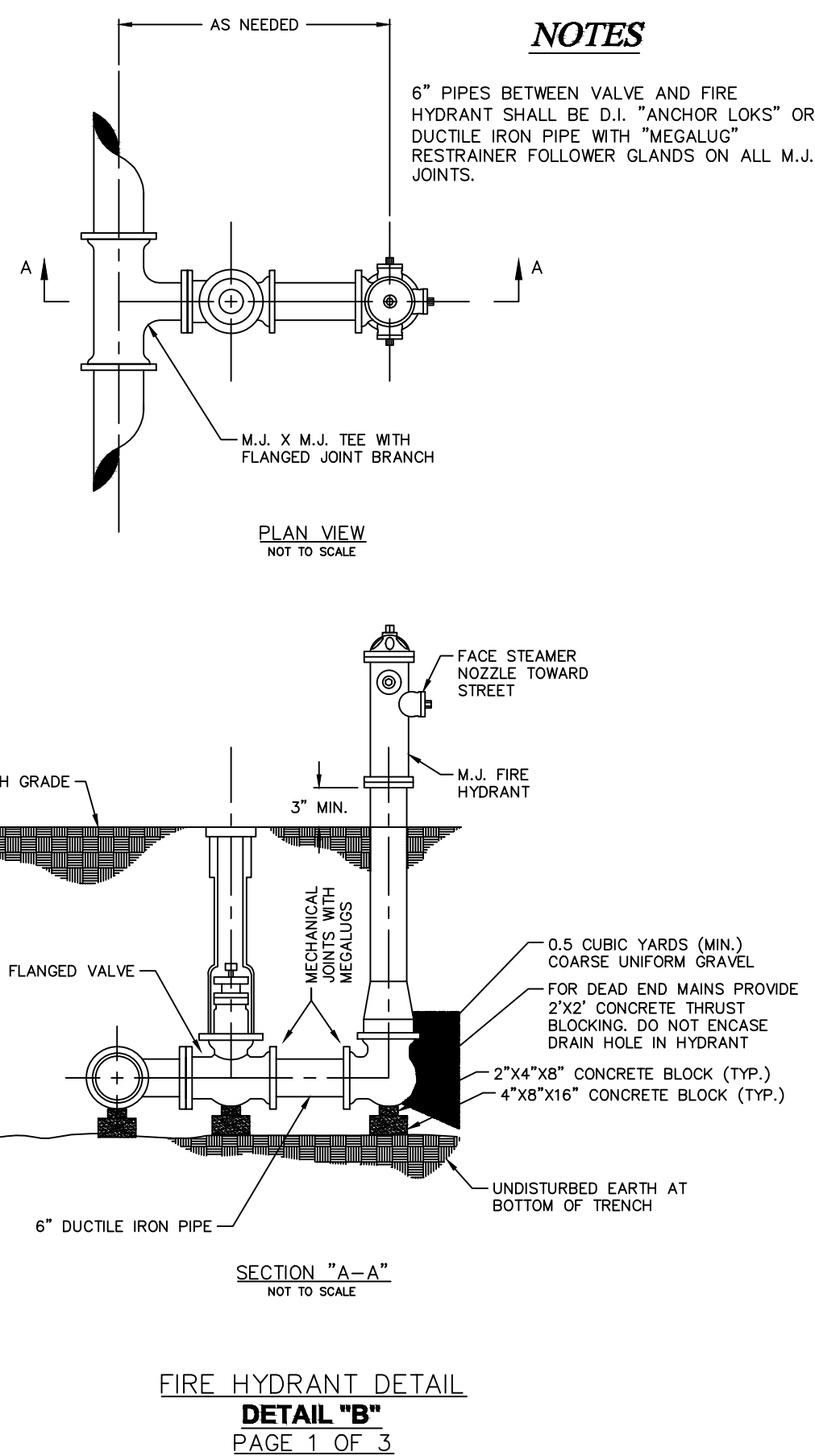

FIRE HYDRANT DETAIL
DETAIL "B"
PAGE 1 OF 3

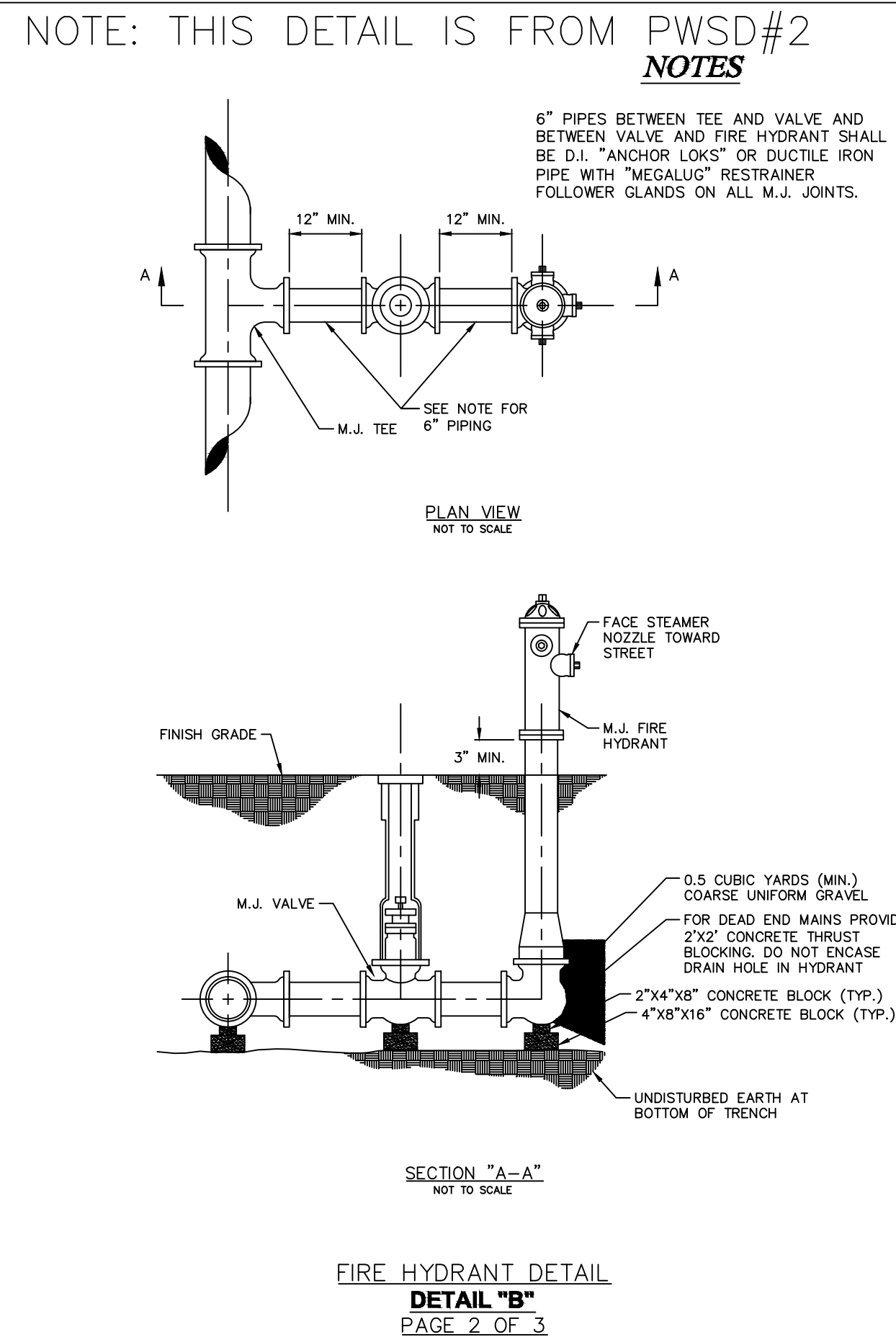

FIRE HYDRANT DETAIL
DETAIL "B"
PAGE 2 OF 3

NOTE: MODIFIED DETAIL FROM PWS#2

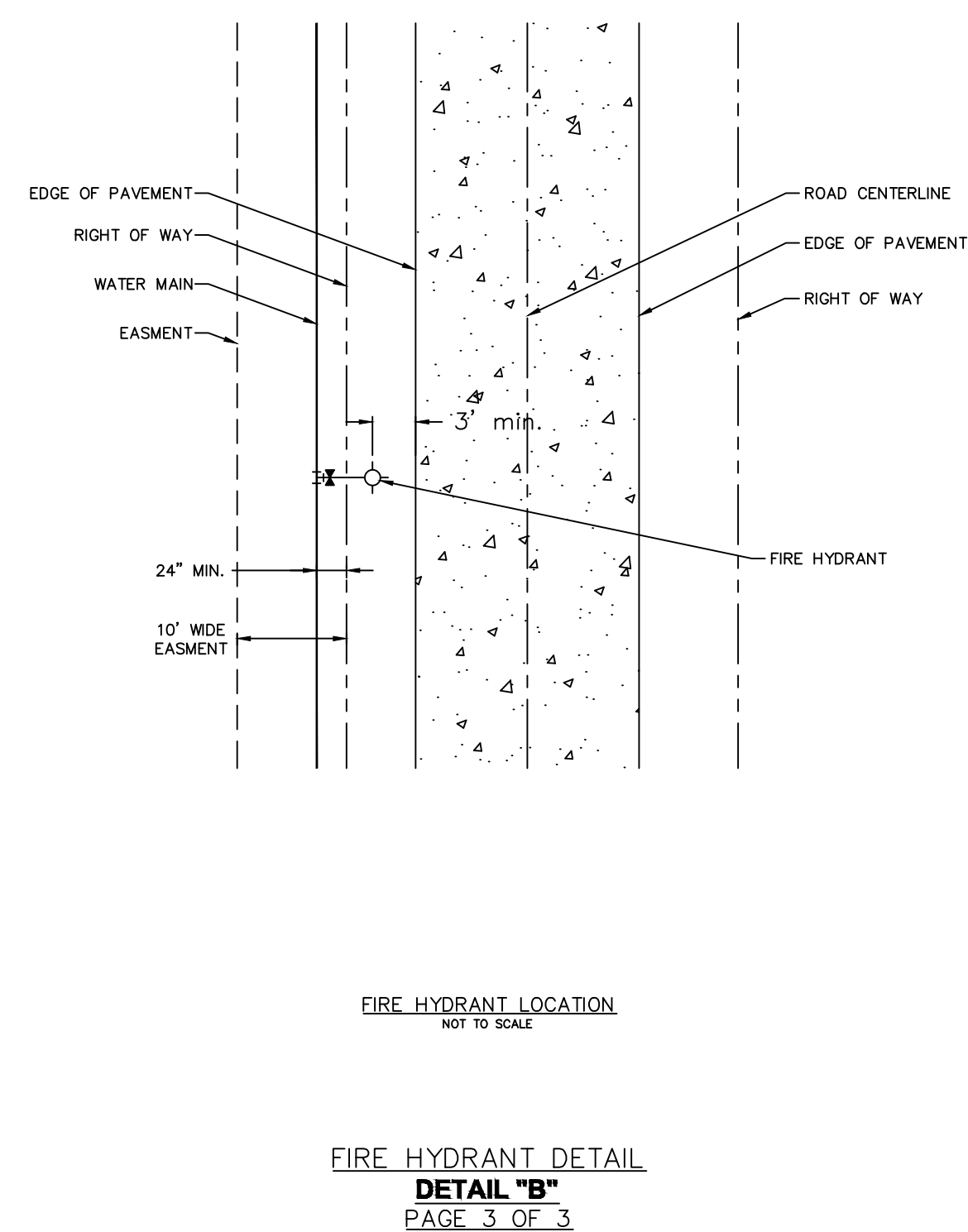

FIRE HYDRANT LOCATION
DETAIL "B"
PAGE 3 OF 3

NOTE: MODIFIED DETAIL FROM PWS#2

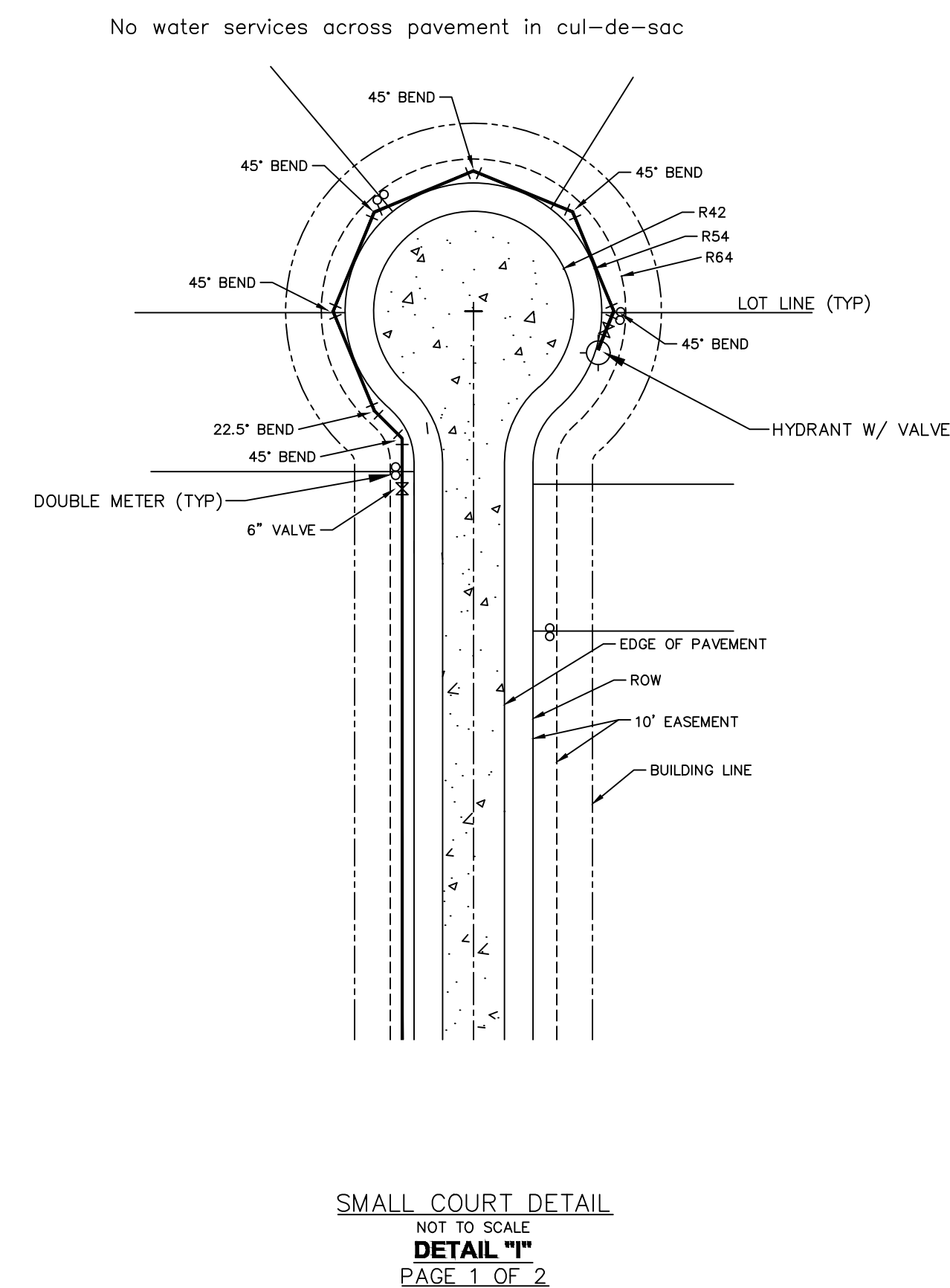

SMALL COURT DETAIL
DETAIL "I"
PAGE 1 OF 2

PROJECT TITLE:

ELLA'S PLACE

EMGE ROAD
CITY OF O'FALLON
ST. CHARLES COUNTY
MO. 63366

Issue Date: 09/26/2018

ENGINEERING
PLANNING
SURVEYING
221 Point View Blvd.
St. Charles, MO 63301
636-928-5662
FAX 928-1718



DISCLAIMER OF RESPONSIBILITY
I hereby specify that the documents intended to be authenticated by my seal are limited to this sheet, and I hereby disclaim any responsibility for all other Drawings, Specifications, Estimates, Reports or other documents or instruments relating to or intended to be used for any part or parts of the architectural or engineering project or survey.

REVISIONS

DATE	CITY COMMENTS
11/29/18	CITY COMMENTS
01/09/19	CITY COMMENTS
03/22/21	CLIENT COMMENTS
05/05/21	CITY COMMENTS
05/21/21	CITY COMMENTS

Developer / Owner:
Schneider Custom Homes
429 North Main Street
O'Fallon, MO 63366
636-240-0930

WATER DETAILS

P+Z No. #19-007760

Approval Date: 11/05/2020

City No. #

Page No.

14 of 18

ENGINEERS SEAL DOES NOT APPLY TO DETAILS ON THIS SHEET.