

ELEVATION

NOTES

1. Frames of opening to be set in place not in concrete.
2. Service to be run at right angles from vault to street.
3. Standard precast trapezoidal boxes available.

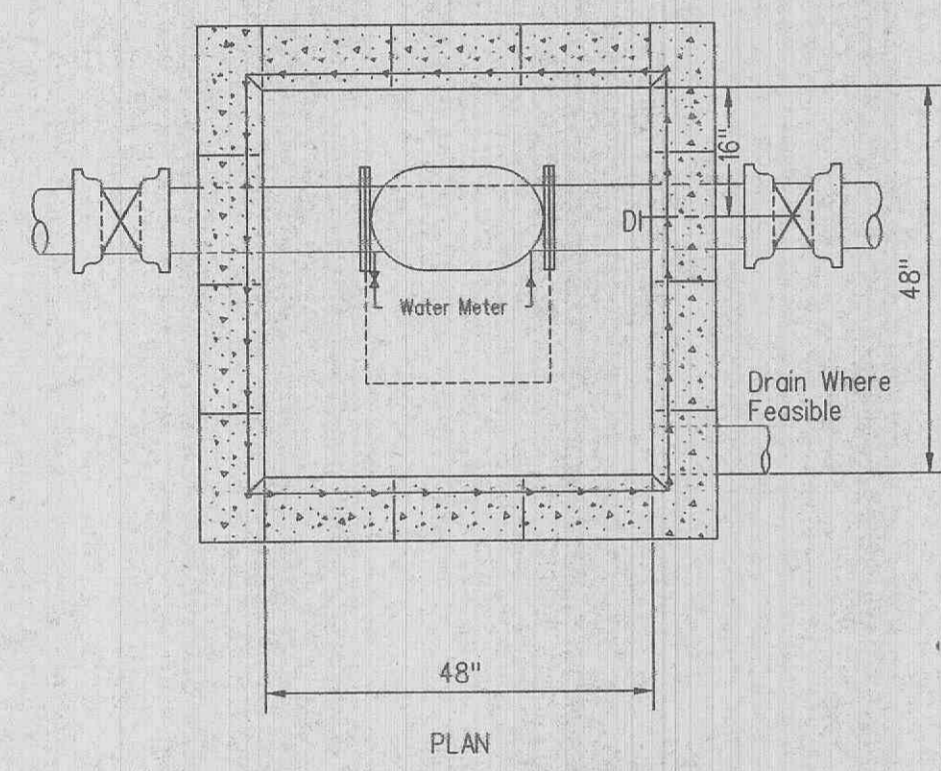

PLAN

WATER METER BOX FOR 8" METER

15 NTS

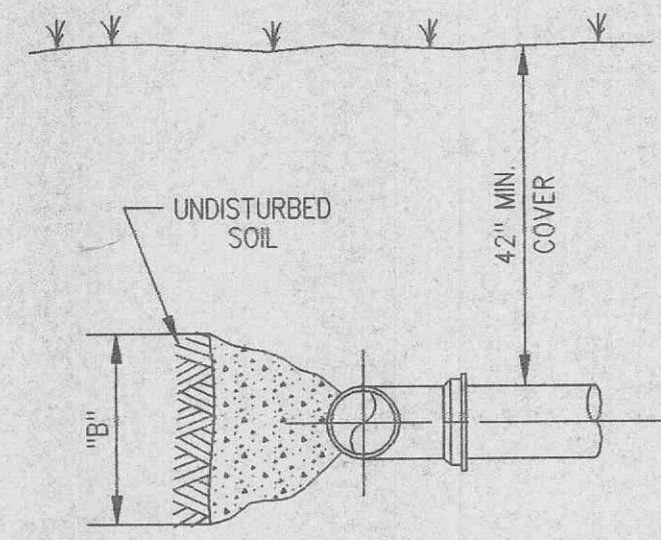

SECTION A-A (TYPICAL FOR ALL THRUST BLOCKS)

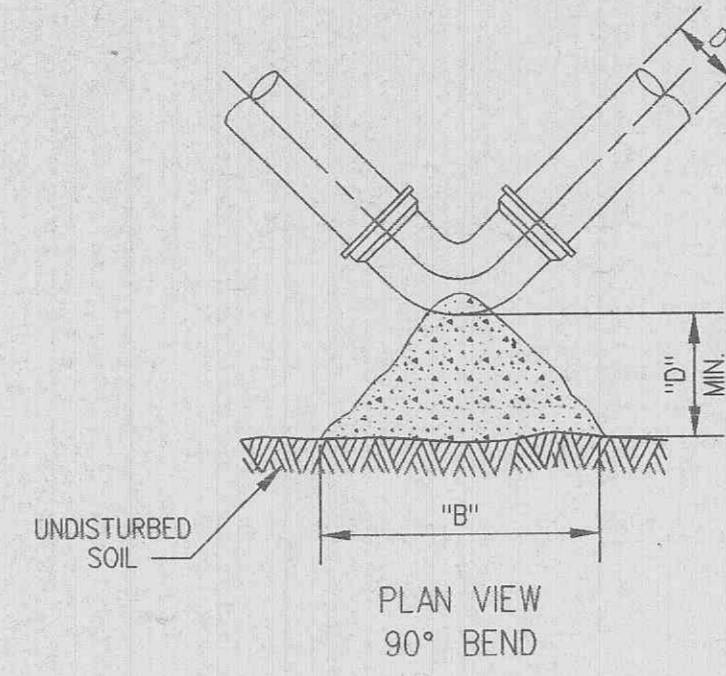

PLAN VIEW 90° BEND

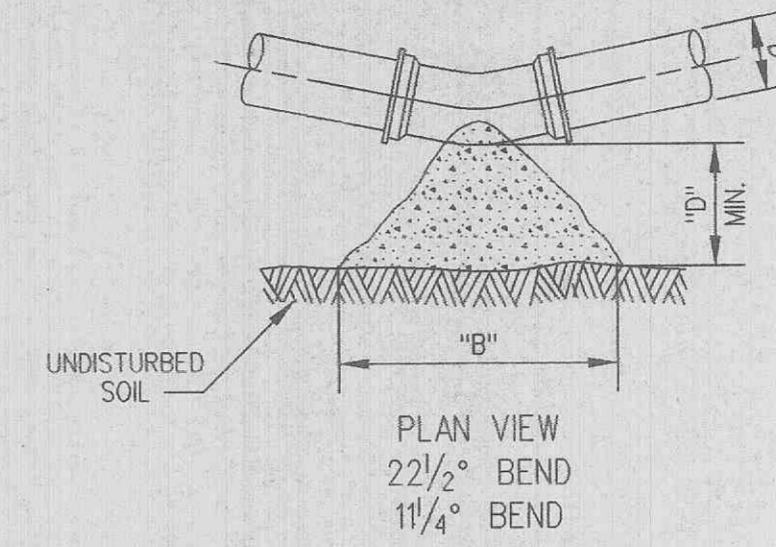

PLAN VIEW 22 1/2° BEND 1 1/4" BEND

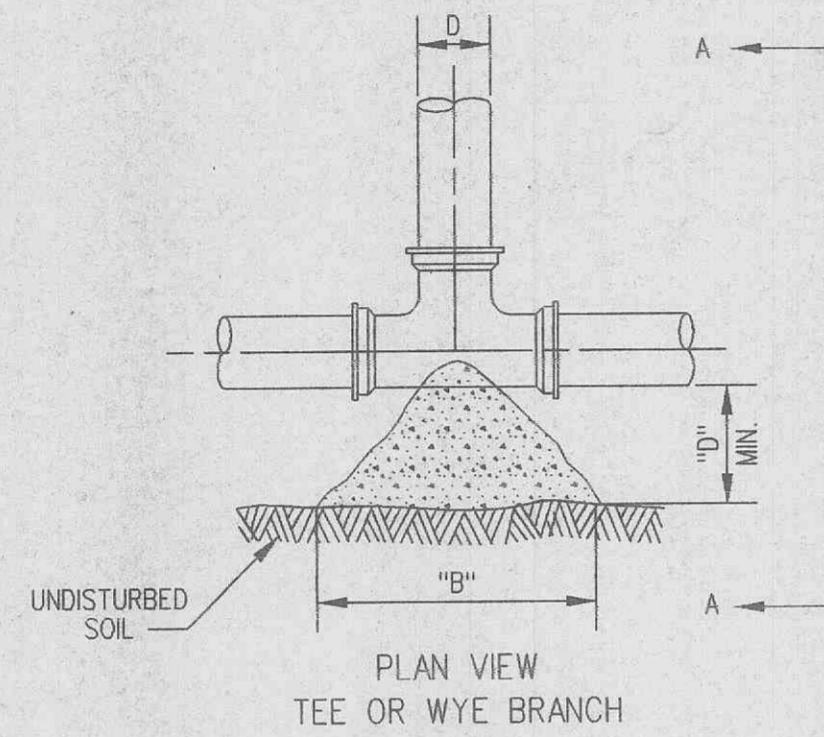

PLAN VIEW TEE OR WYE BRANCH

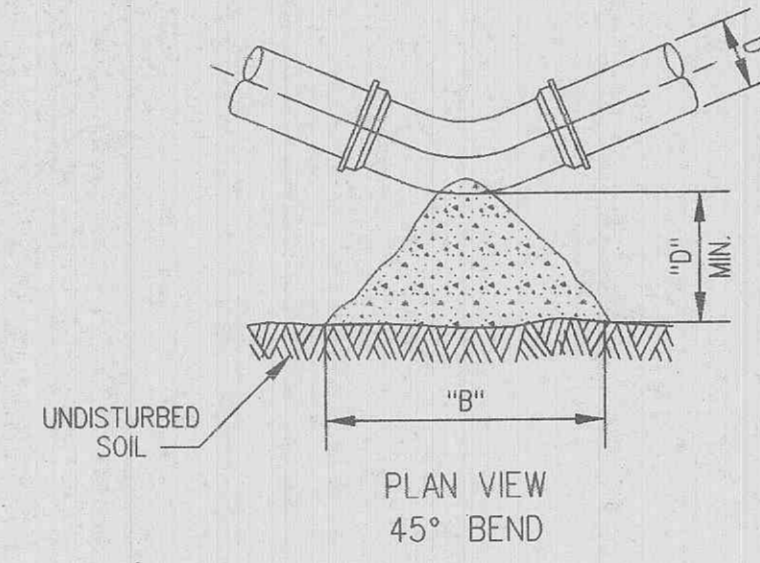

PLAN VIEW 45° BEND

HORIZONTAL THRUST BLOCK DETAILS

21 NTS

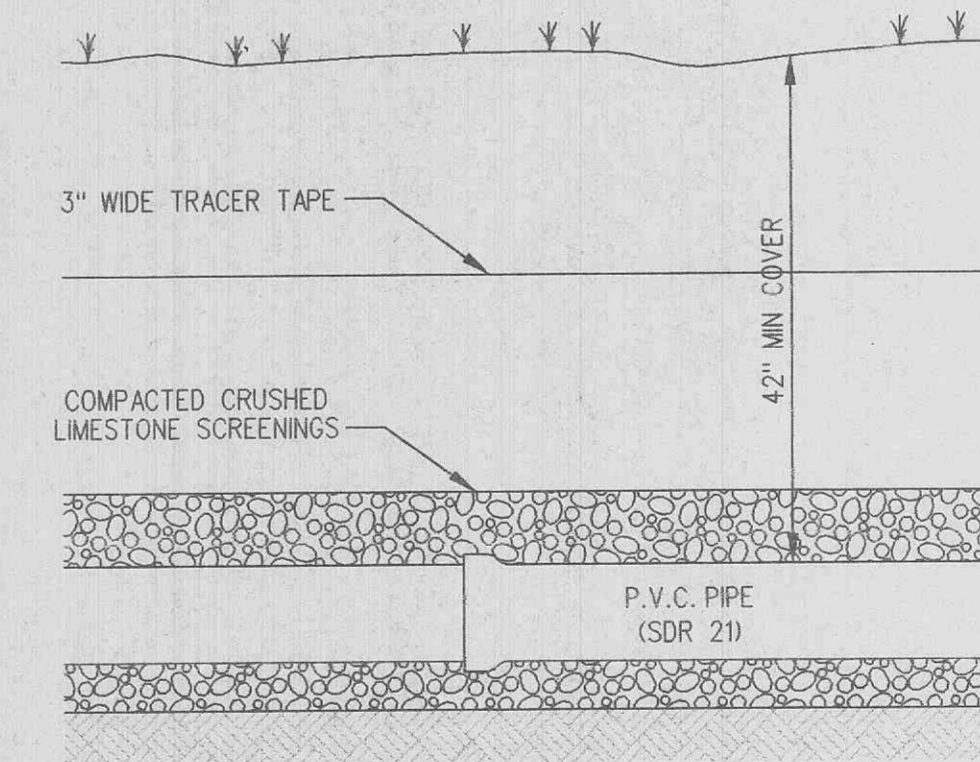

TRENCH DETAIL

23 NTS

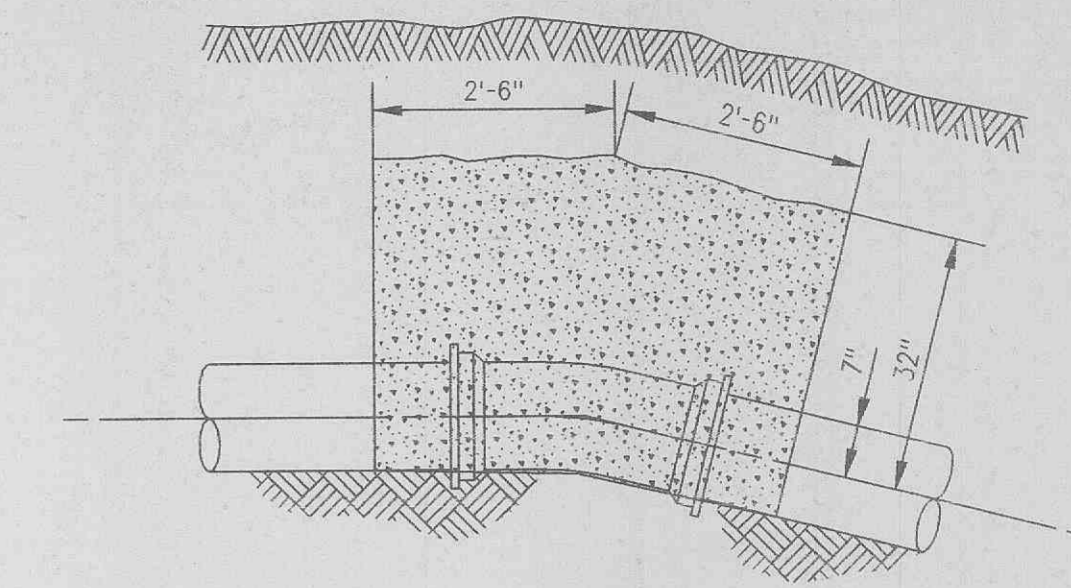

HORIZONTAL THRUST BLOCK DETAILS

22 NTS

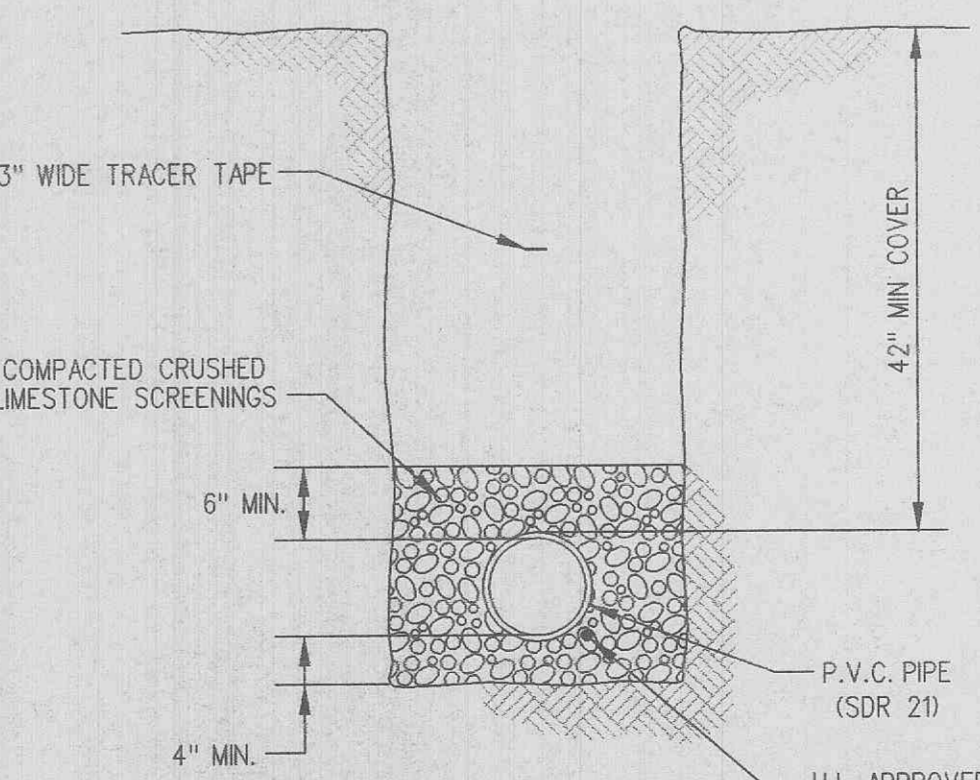

TRENCH DETAIL

23 NTS

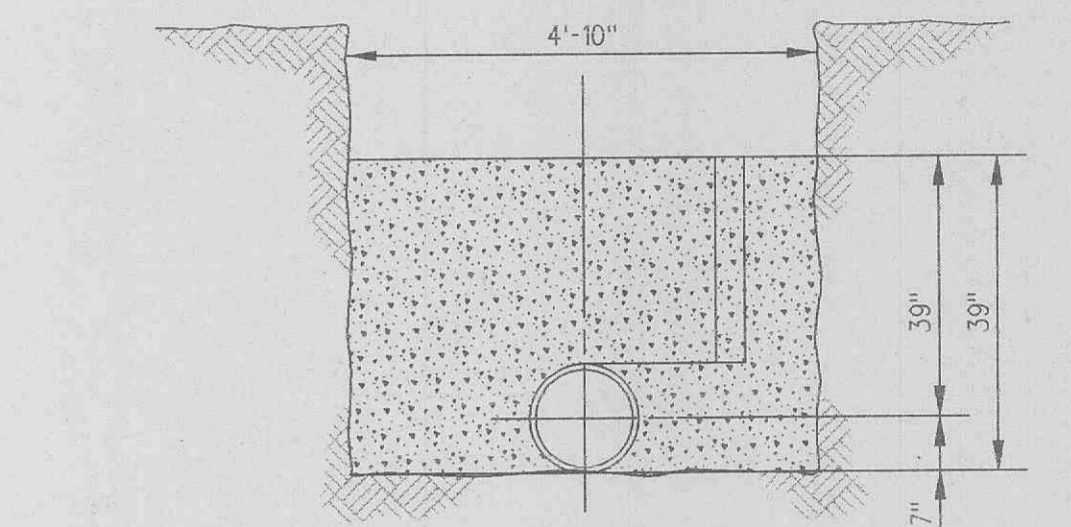

HORIZONTAL THRUST BLOCK DETAILS

22 NTS

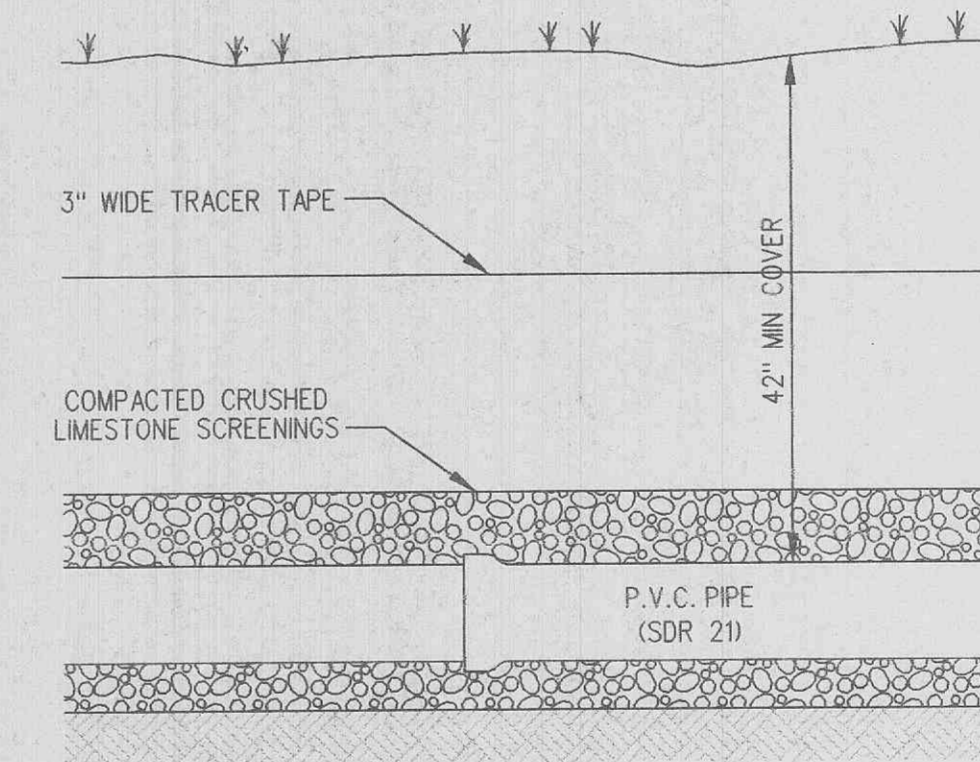

TRENCH DETAIL

23 NTS

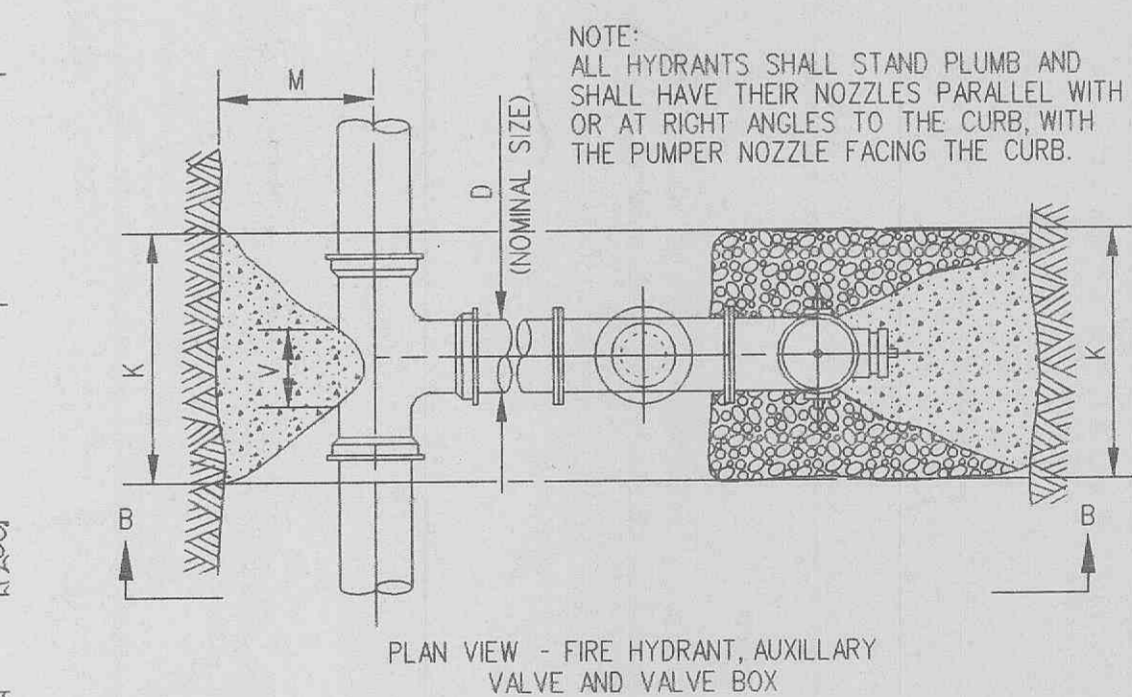

PLAN VIEW - FIRE HYDRANT, AUXILIARY VALVE AND VALVE BOX

FIRE HYDRANT THRUST BLOCK DIMENSIONS									
D	K	V	M	H	N	P	R		
6"	28"	6"	24"	24"	42"	42"	36"	30"	

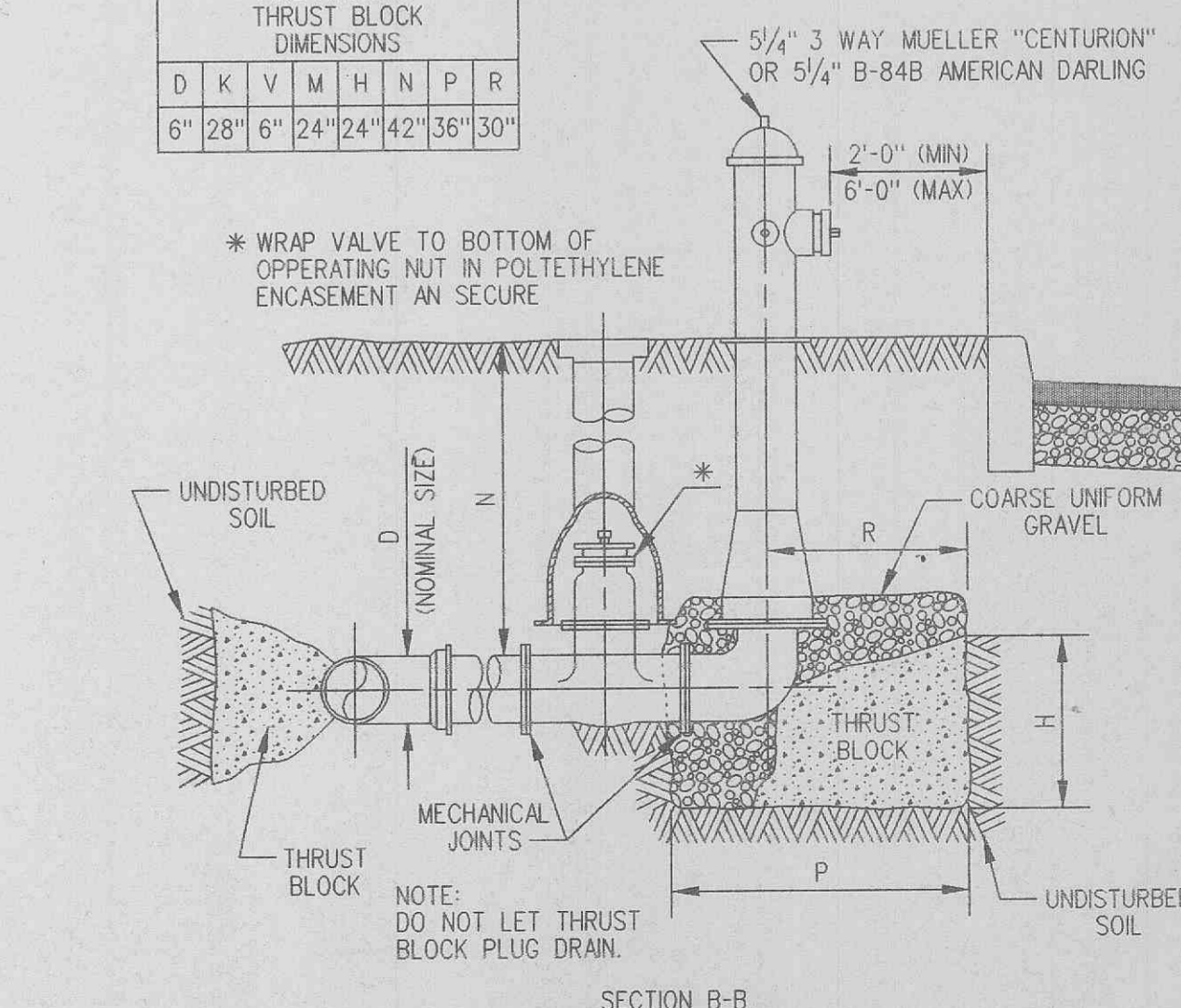

SECTION B-B

FIRE HYDRANT DETAIL

24 NTS