

PER RN #19 ON SHEET 2

All traffic signals, street signs, sign post, backs and bracket arms shall be painted black using Corboline Rust Bond Penetrating Sealer SG and Corboline 133 HB paint (or equivalent as approved by City of O'Fallon and MoDOT).

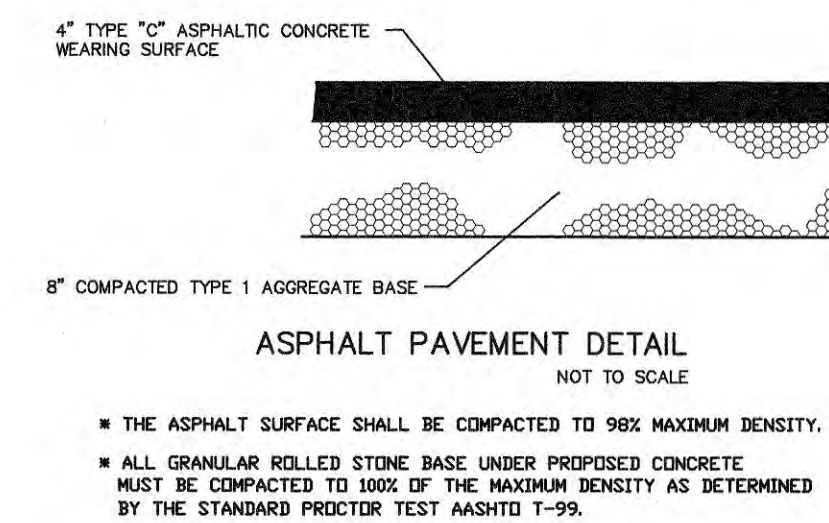

STABILIZED CONSTRUCTION ENTRANCE

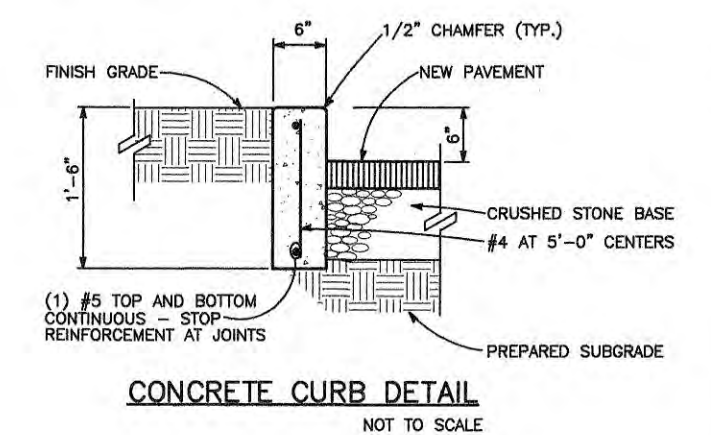
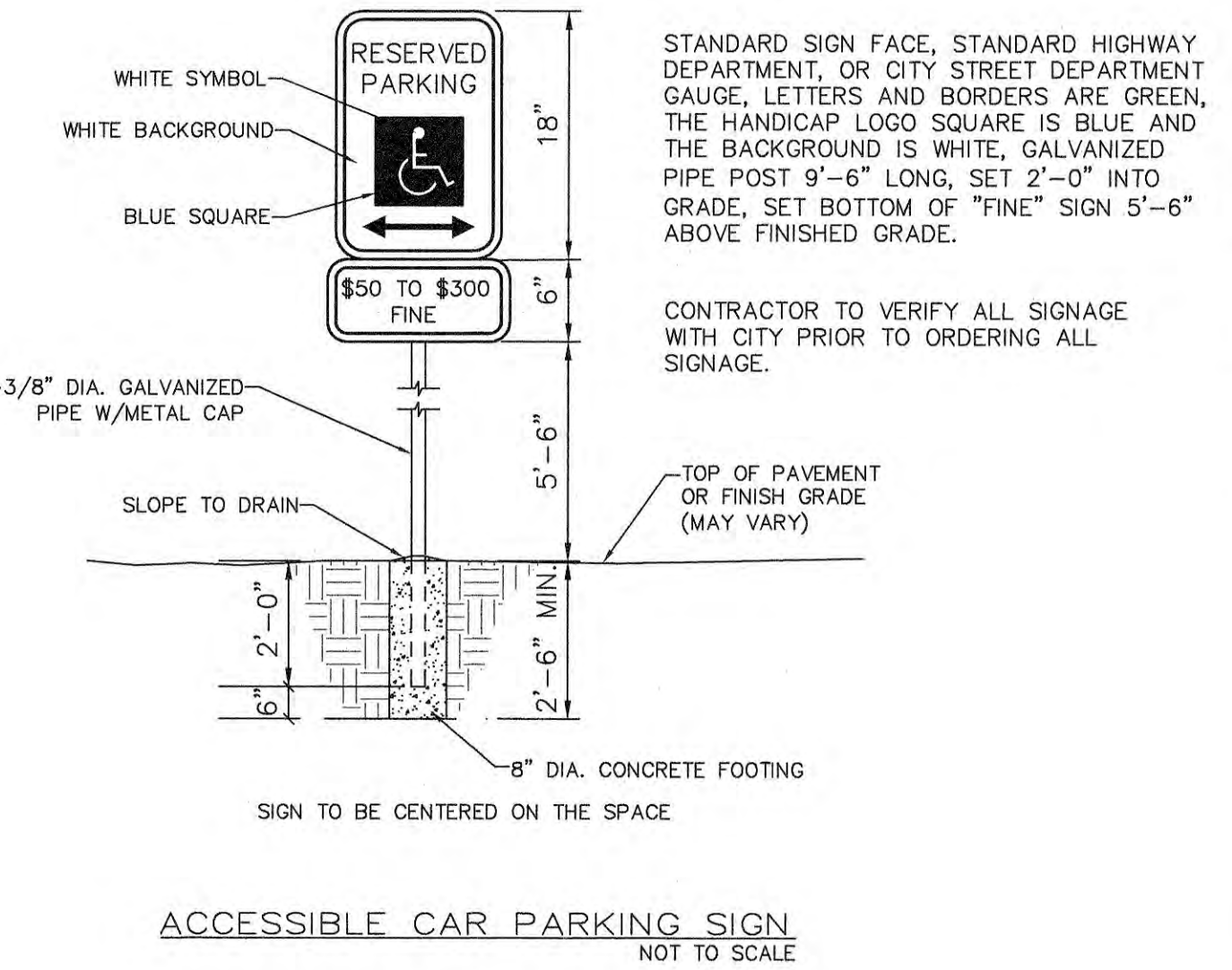
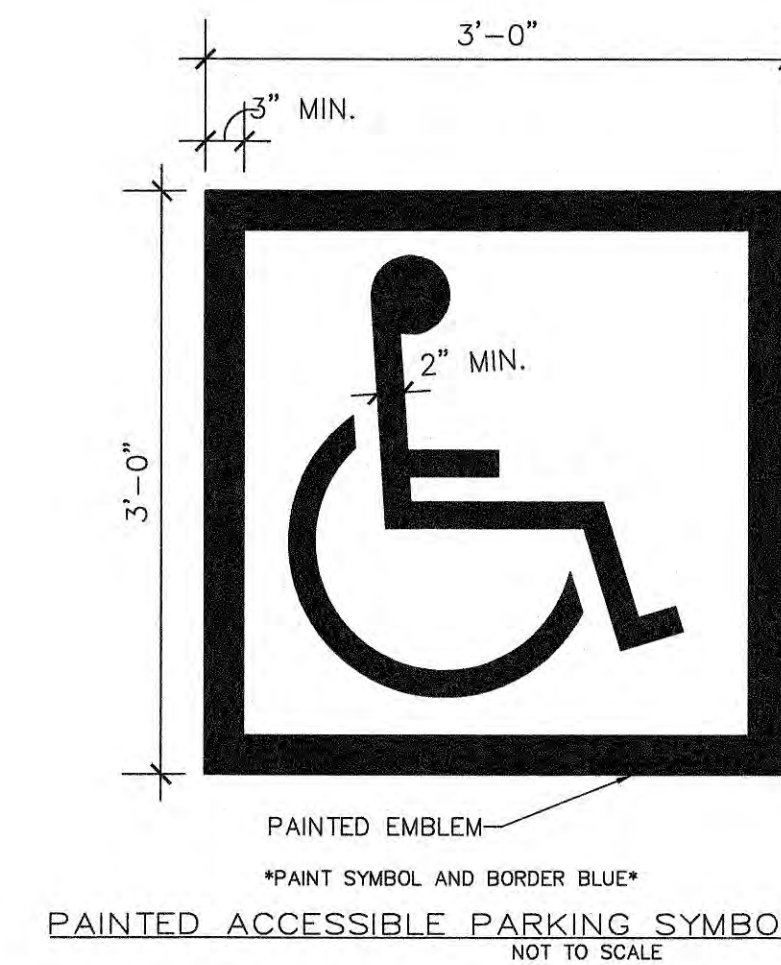
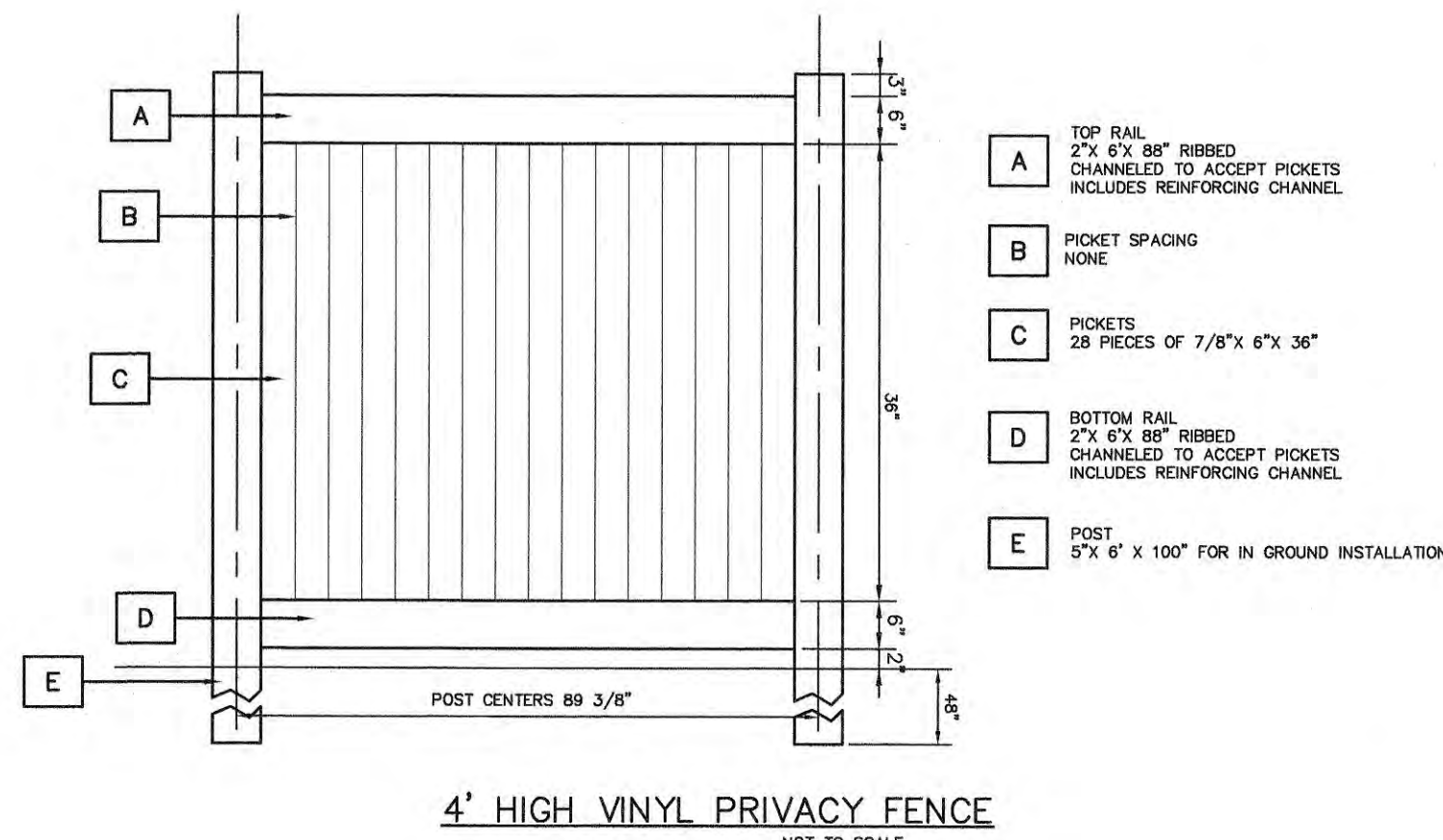
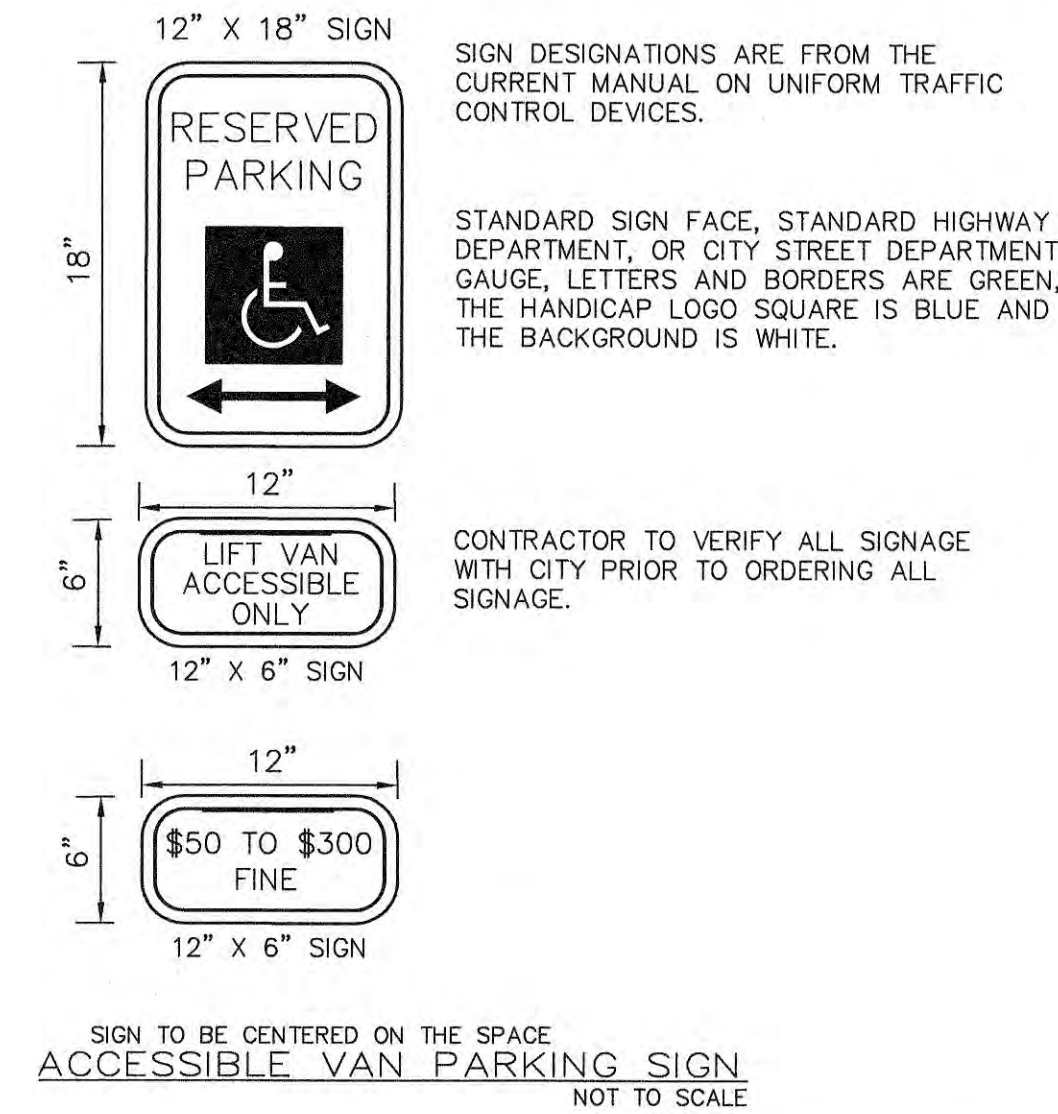
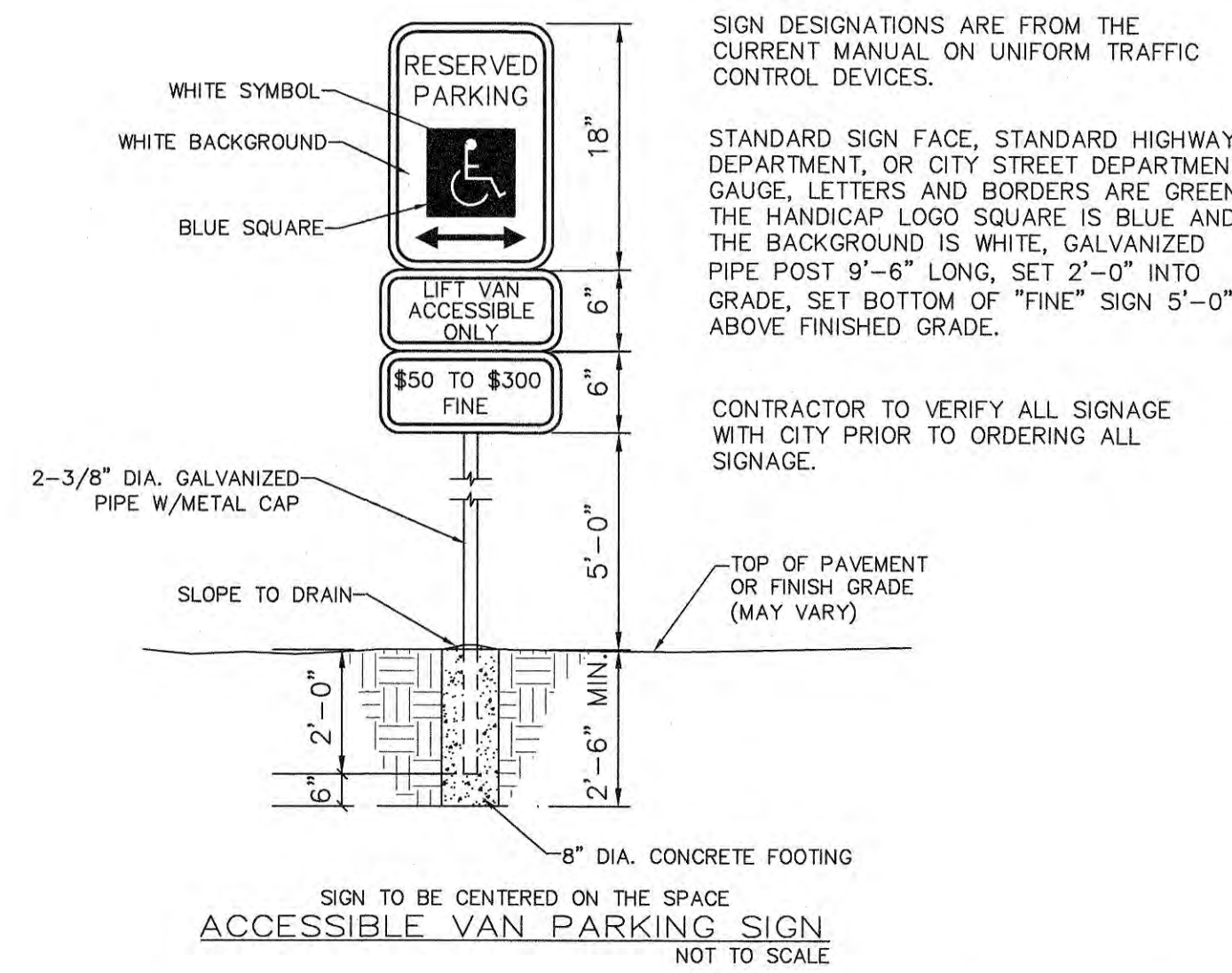
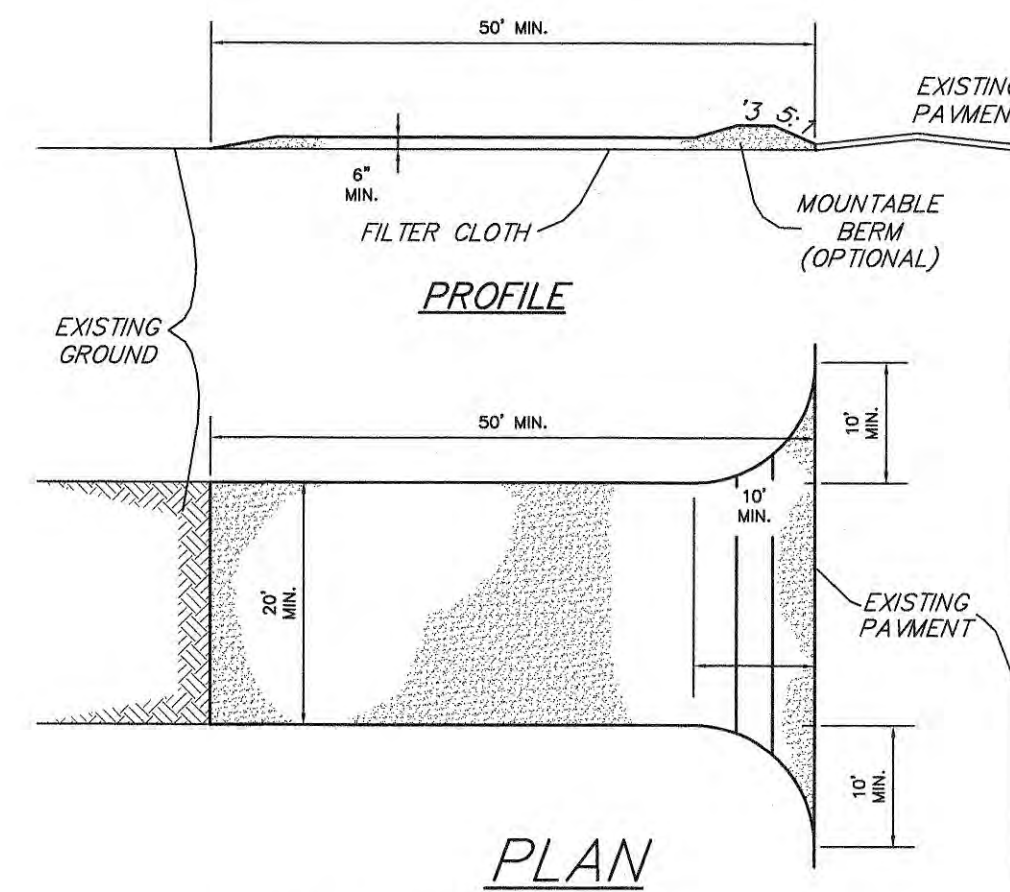
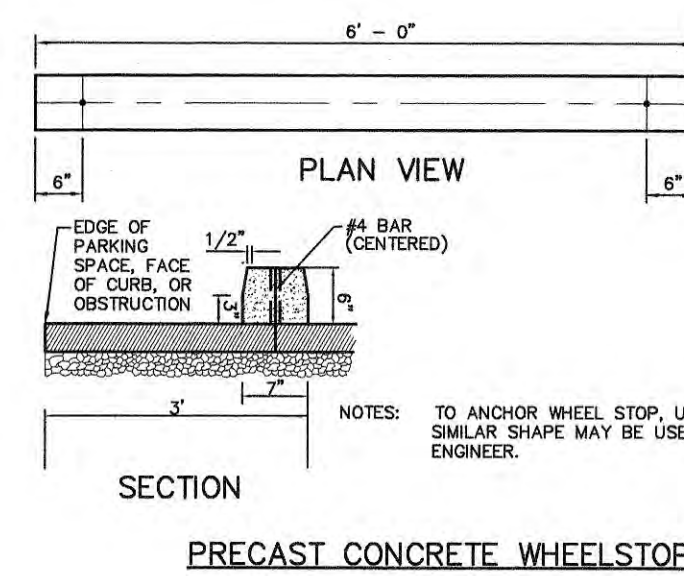

CONSTRUCTION SPECIFICATIONS

- Stone Size - Use 2" stone, or reclaimed or recycled concrete equivalent.
- Length - As required, but not less than 50 feet minimum length would apply).
- Thickness - Not less than six (6) inches.
- Width - Twenty (20) foot minimum, but not less than the full width at points where ingress or egress occurs.
- Filter Cloth - Will be placed over the entire area prior to placing of stone. Filter will not be required on a single family residence lot.
- Surface Water - All surface water flowing or diverted toward construction entrances shall be piped across the entrance. If piping is impractical, a mountable berm with 5:1 slopes will be permitted.
- Maintenance - The entrance shall be maintained in a condition which will prevent tracking or flowing of sediment onto public rights-of-way. This may require periodic top dressing with additional stone as conditions demand and repair and/or cleanout of any measures used to trap sediment. All sediment spilled, dropped, washed or tracked onto public rights-of-way must be removed immediately.
- Washing - Wheels shall be cleaned to remove sediment prior to entrance onto public rights-of-way. When washing is required, it shall be done on an area stabilized with stone and which drains into an approved sediment trapping device.
- Periodic inspection and needed maintenance shall be provided after each rain.
- If water is not available, a water truck is to be provided.

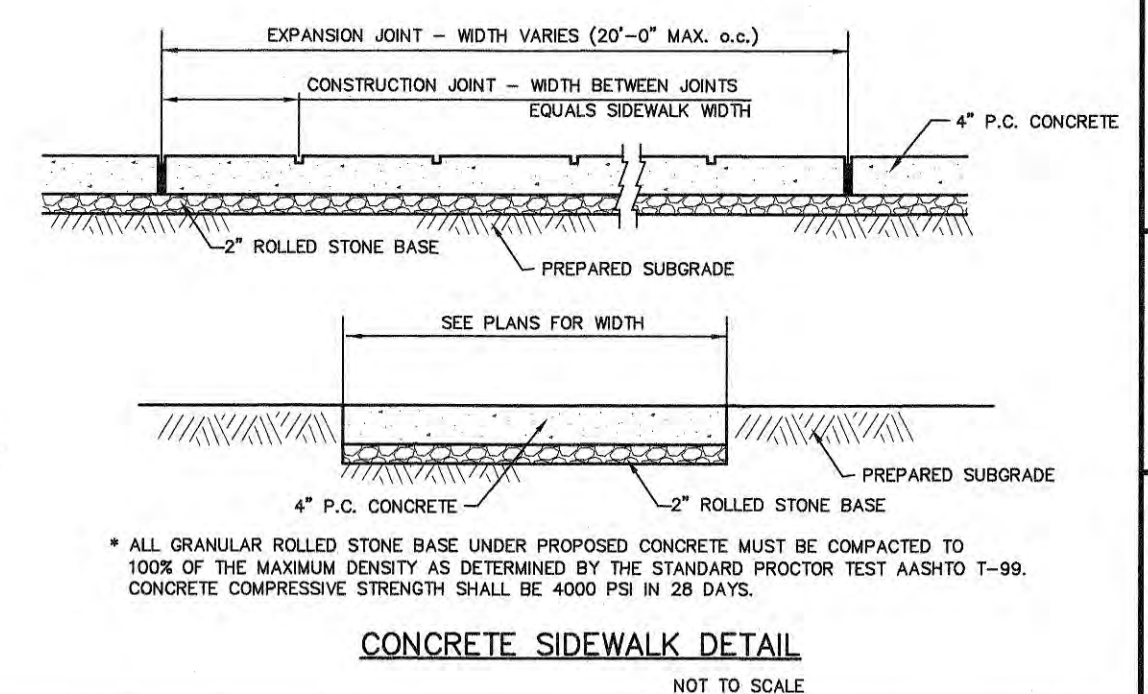
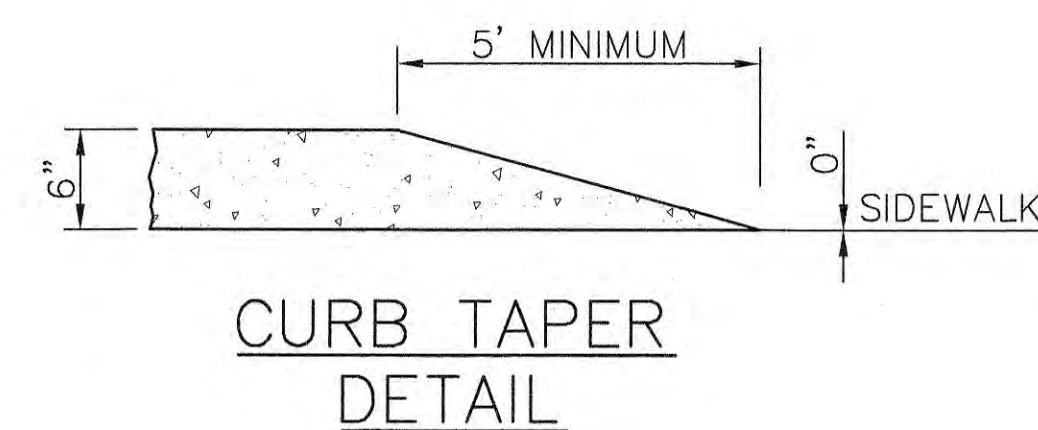
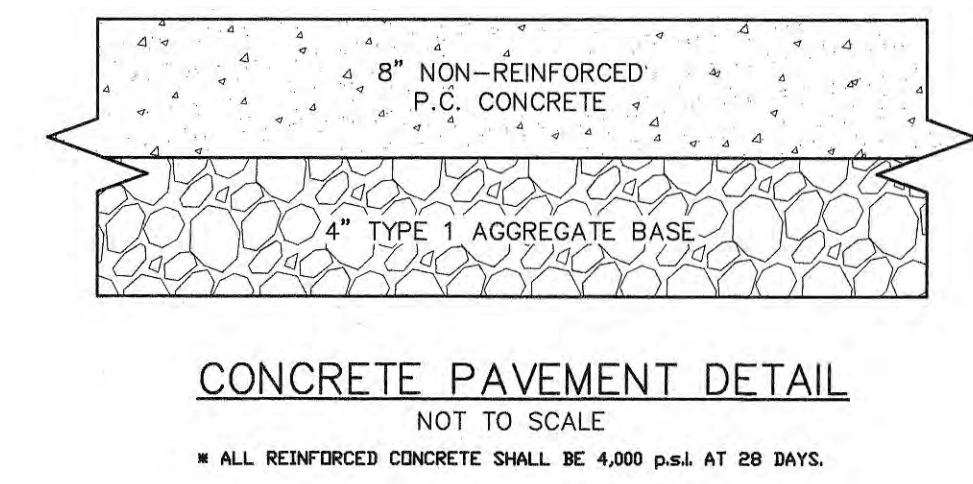
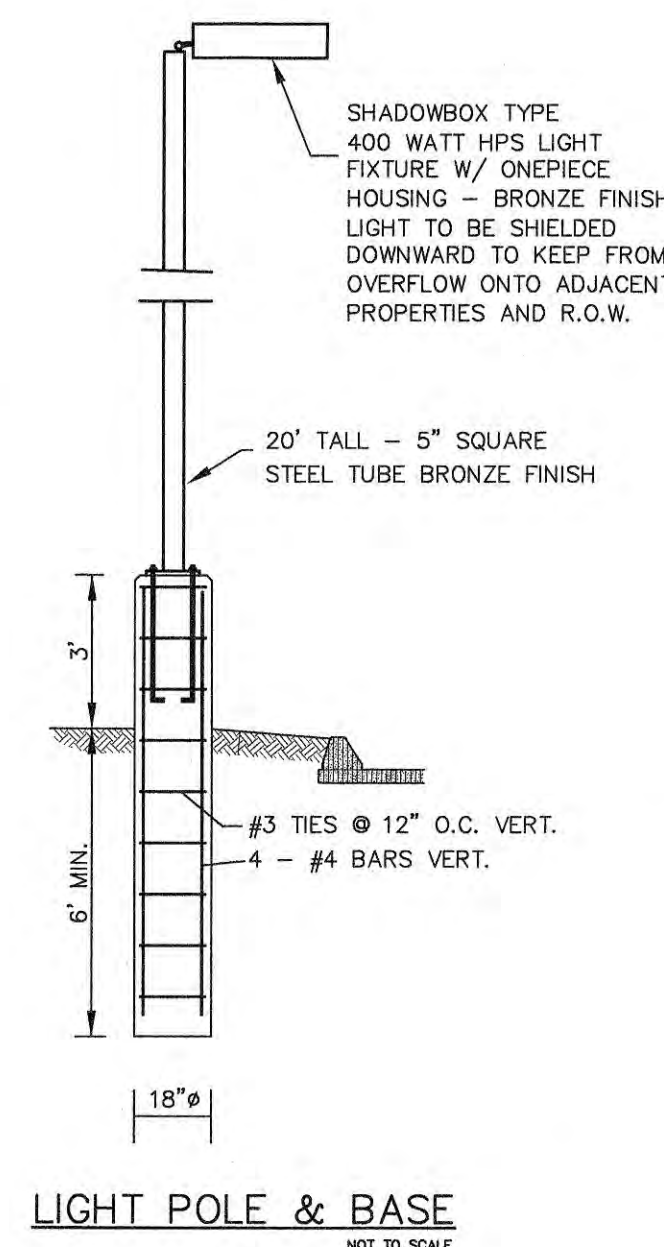

PROJECT TITLE:
FALLON CREST TOWNHOMES

ENGINEERING PLANNING SURVEYING
221 Point West Blvd.
St. Charles, MO 63301
636-928-5552
FAX 928-1718

DISCLAIMER OF RESPONSIBILITY
I hereby specify that the documents intended to be authorized by my seal are limited to this sheet, and I hereby disclaim any responsibility for all other drawings, specifications, estimates, reports or other documents or instruments relating to or intended to be used for any part or parts of the architectural or engineering project or work.

STATE OF MISSOURI
CLIFFORD L. HEITMANN
NUMBER E-29817
PROFESSIONAL ENGINEER
CLIFFORD L. HEITMANN
CIVIL ENGINEER
E29817
Copyright 2019
Box Engineering Company, Inc.
Engineering Authority No. 000655
Surveying Authority No. 000144
All Rights Reserved

REVISIONS

8-15-19	city comments
9-3-19	city comments

Developer / Owner:
CORPORATE GROUP INC.
2500 S. OLD HWY 94, SUITE 200
ST. CHARLES, MO. 63303
636-946-0761

CONSTRUCTION DETAILS

P-I-Z No. #19-005136
Approval Date: July 18, 2019
City No. #

Page No.
10 of 20

Box Project # 85-1820F Issue Date: 7/22/2019