

* The discharge point of all flared end sections shall be protected by rip rap or other approved means.
 ** Rip rap shown at flared end sections will be evaluated in the field by the Engineer, Contractor, and City Inspectors after installation for effectiveness and field modified, if necessary to reduce erosion on and off site.

Size	Style	Adhesive	Message (Part #)
3 7/8" TO 4"	Crystal Cap or Standard Style	Epoxy	No Dumping Drains to Waterway

Sieve	Maximum	Minimum
12 inch	90	70
6 inch	30	10
1/2 inch	5	0

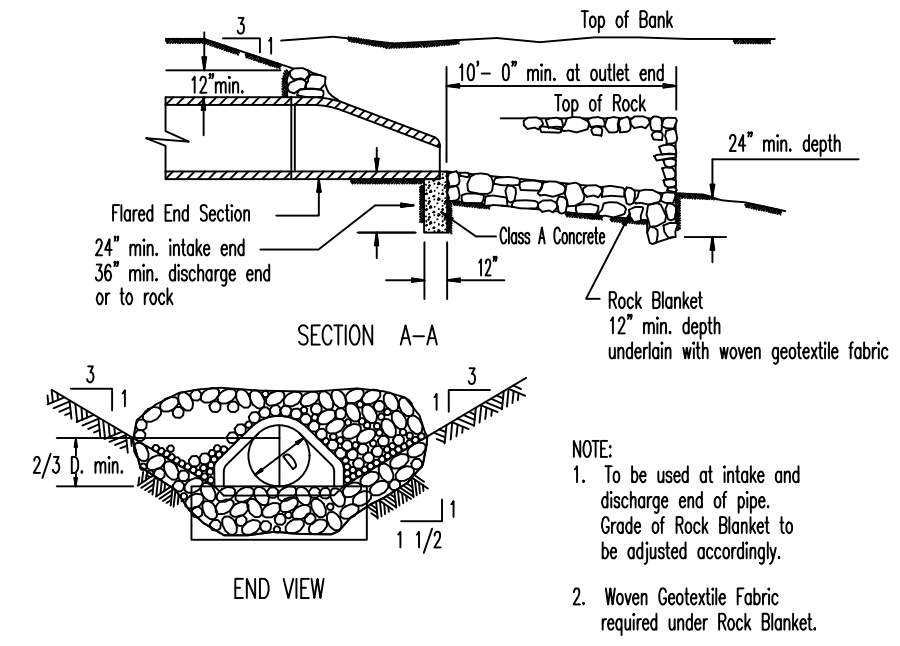
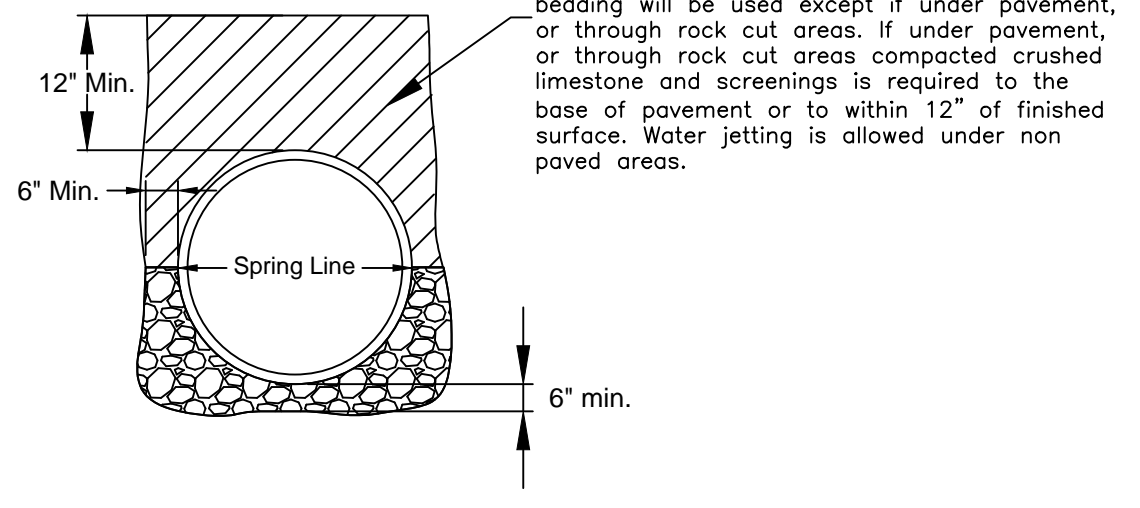
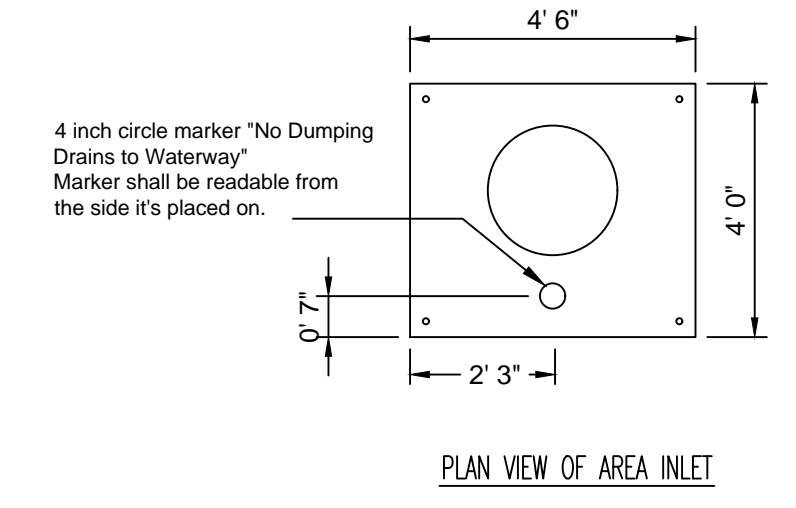
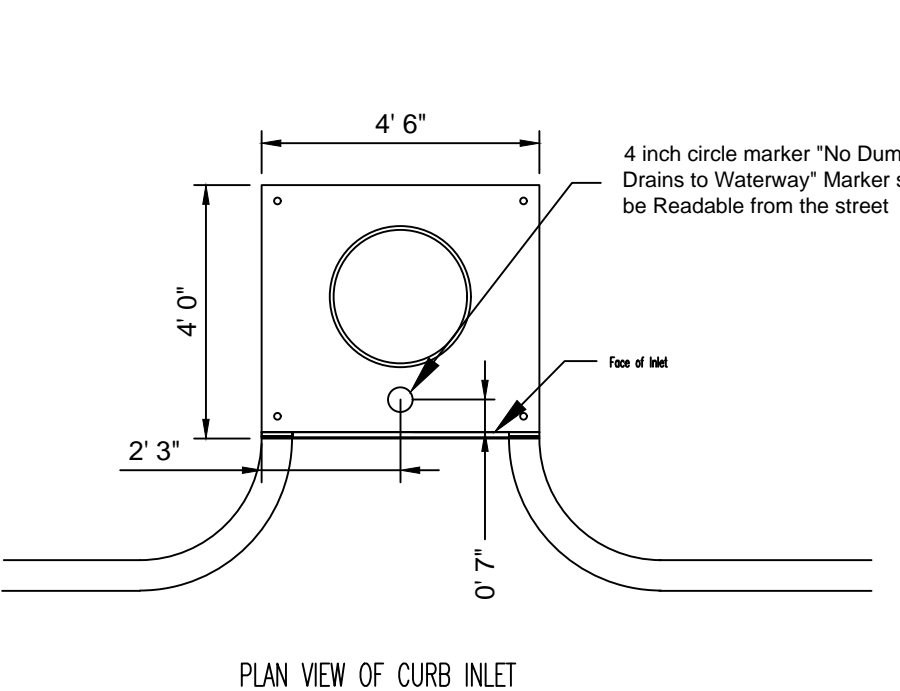

NOTE:
 1. To be used at intake and discharge end of pipe. Grade of Rock Blanket to be adjusted accordingly.
 2. Woven Geotextile Fabric required under Rock Blanket.

CITY OF O'FALLON
 ENGINEERING DEPARTMENT
 O'FALLON, MISSOURI

CITY OF O'FALLON
 ENGINEERING DEPARTMENT
 O'FALLON, MISSOURI

CITY OF O'FALLON
 ENGINEERING DEPARTMENT
 O'FALLON, MISSOURI

CITY OF O'FALLON
 ENGINEERING DEPARTMENT
 O'FALLON, MISSOURI

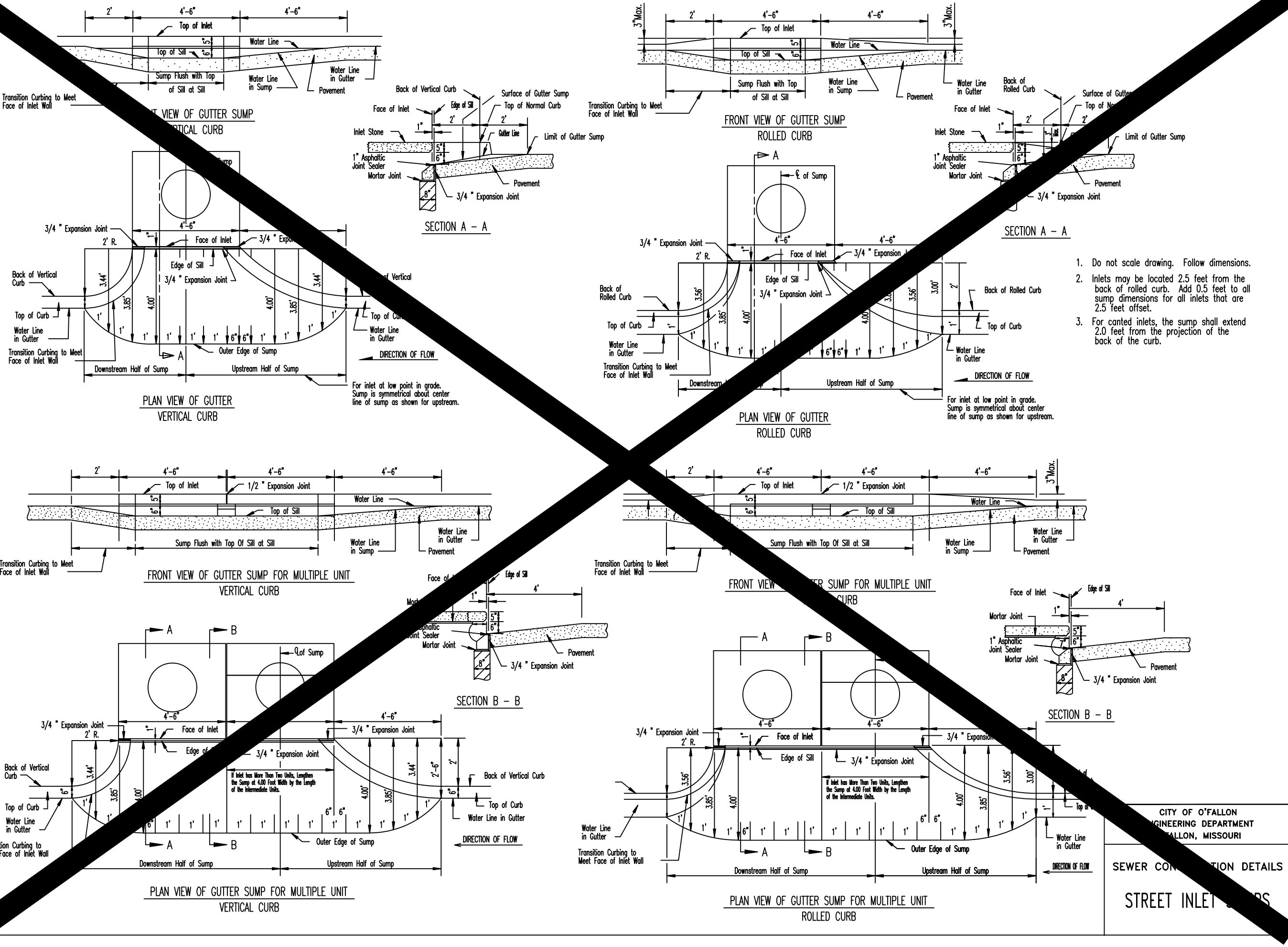

SEWER CONSTRUCTION DETAILS
 STREET INLET DETAILS

1. Do not scale drawing. Follow dimensions.
 2. Inlets may be located 2.5 feet from the back of rolled curb. Add 0.5 feet to all sump dimensions for all inlets that are 2.5 feet offset.
 3. For curbed inlets, the sump shall extend 2.0 feet from the projection of the back of the curb.

CITY OF O'FALLON
 ENGINEERING DEPARTMENT
 O'FALLON, MISSOURI

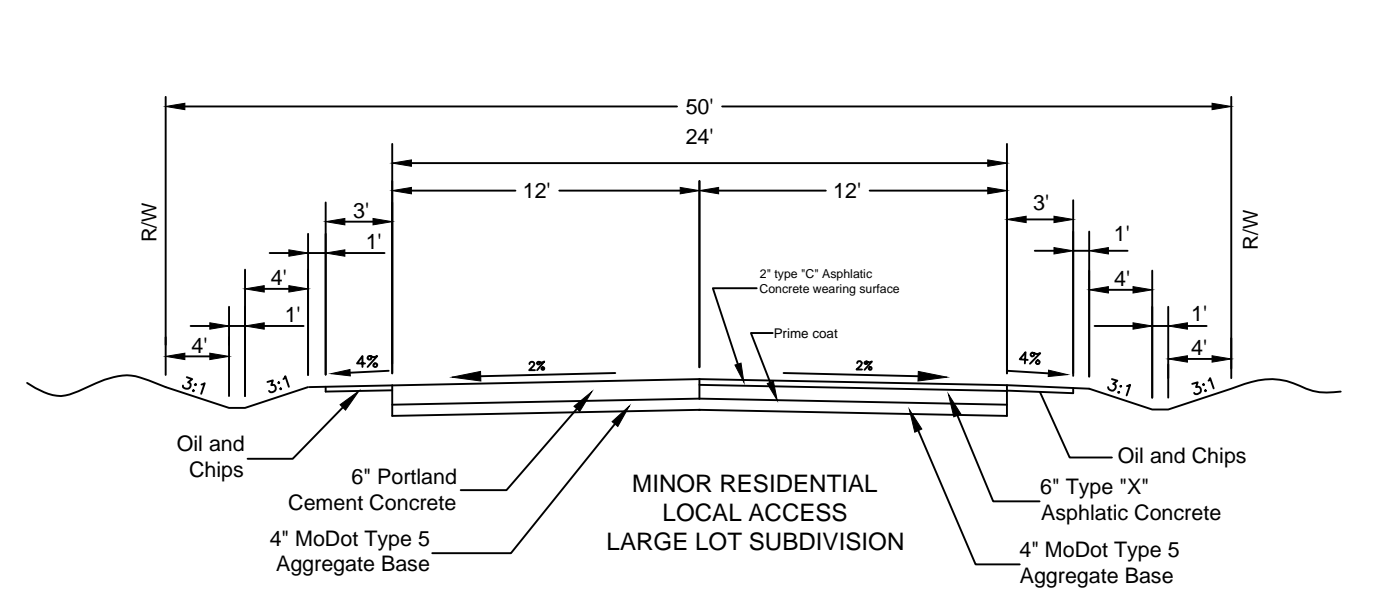

CITY OF O'FALLON
 ENGINEERING DEPARTMENT
 O'FALLON, MISSOURI

GENERAL NOTES

- IF A PERMIT IS ISSUED TO REPLACE THE EXISTING ASPHALTIC CONCRETE PAVEMENT WITH FULL DEPTH BITUMINOUS CONCRETE PAVEMENT AND CONCRETE PAVEMENT IS FOUND UNDER THE EXISTING ASPHALTIC CONCRETE PAVEMENT, THE APPLICANT WILL BE REQUIRED TO FOLLOW THE DETAIL FOR BITUMINOUS CONCRETE OVER CONCRETE PAVEMENT CUT. THE APPLICANT WILL USE DURACRETE OR EQUIVALENT TO REPLACE THE EXISTING CONCRETE AND USE 4" TYPE 5 AGGREGATE OVER GRANULAR BACKFILL OR PUGMILL AS A SUBBASE. DURACRETE SETS UP IN APPROXIMATELY 4 HOURS AT WHICH TIME THE BR-1 BITUMINOUS CONCRETE OVERLAY CAN BE APPLIED TO THE BASE COURSE.
- IF BITUMINOUS CONCRETE OVER CONCRETE PAVEMENT OR CONCRETE PAVEMENT IS BROKEN BEFORE SAW CUTTING THE PAVEMENT FULL CONCRETE SLAB REPLACEMENT WILL BE REQUIRED.
- MINIMUM THICKNESS FOR PAVEMENT REPLACEMENT IS:
 ALL RESIDENTIAL MINOR AND LOCAL STREETS 7 1/2"
 RESIDENTIAL COLLECTOR 9 1/2"
 ALL COUNTY AND NON-RESIDENTIAL STREETS 12"
 ALL ARTERIAL STREETS
- IF THE EXCAVATIONS ARE MADE IN THE IMPROVED PORTION OF THE ROW, TWELVE INCHES OF GRANULAR BACKFILL WILL BE PLACED OVER EXPOSED FACILITIES AND CONTROLLED LOW STRENGTH MATERIAL (CLSM) AKA FLOWABLE FILL WILL FILL THE HOLE WITHIN EIGHT INCHES OF THE FINISHED SURFACE FOR CONCRETE PAVEMENT. THERE WILL BE A PLASTIC MEMBRANE PLACED BETWEEN THE ROCK BASE AND THE CLSM TO PREVENT THE MATERIAL FROM BLEEDING INTO THE ROCK BASE. THE REMAINING EIGHT INCHES WILL BE RESTORED BY PLACING A TWENTY EIGHT DAY MINIMUM STRENGTH, FOUR THOUSAND PSI CONCRETE MIX.
- TRENCHED AREA MUST BE SAW CUT TO REMOVE EXIST. PAVT.
- BR-1 ASPH. CONC. MUST BE INSTALLED WITH PAVER.
- BITUMINOUS BASE ASPH. CONC. MUST BE INSTALLED IN TWO (2) COMPACTED LIFTS.
- ONE (1) LANE OF TRAFFIC MUST REMAIN OPEN AT ALL TIMES.
- THE CONTRACTOR WILL BE RESPONSIBLE FOR MAINTENANCE OF TRENCHED AREA AND SUBSEQUENT ASPH. WORK UNTIL WORK IS ACCEPTED.
- THE CONTRACTOR WILL INSTALL AND MAINTAIN ALL NECESSARY CONSTRUCTION SIGNS AS DETERMINED BY FIELD INSPECTOR.

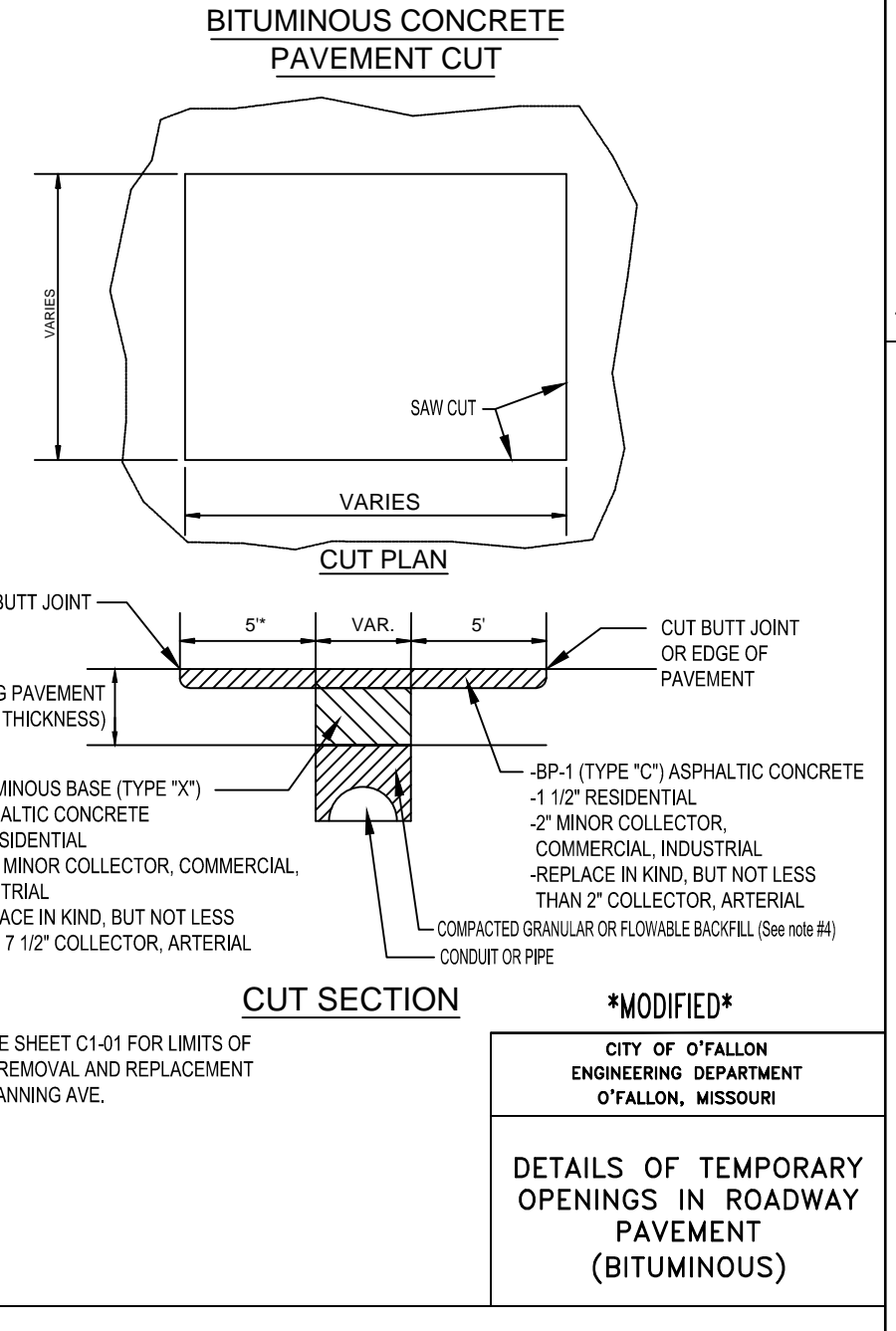

CITY OF O'FALLON
 ENGINEERING DEPARTMENT
 O'FALLON, MISSOURI

DETAILS OF TEMPORARY OPENINGS IN ROADWAY PAVEMENT (BITUMINOUS)

MODIFIED

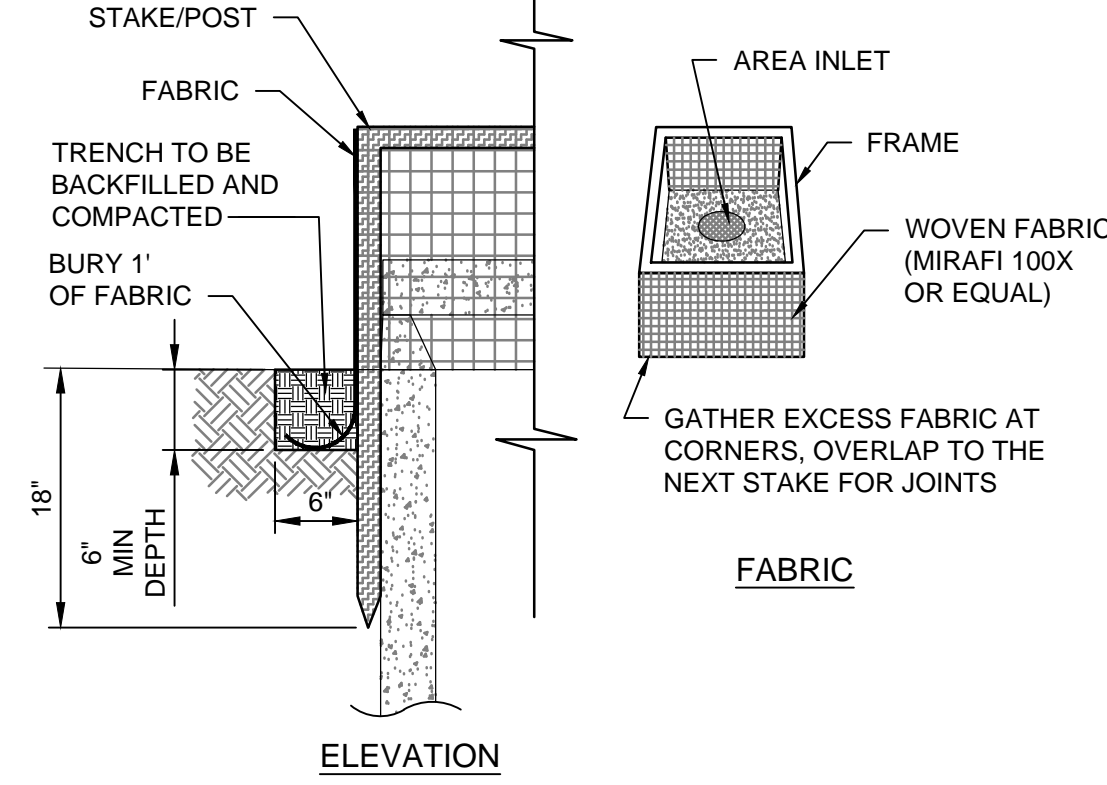
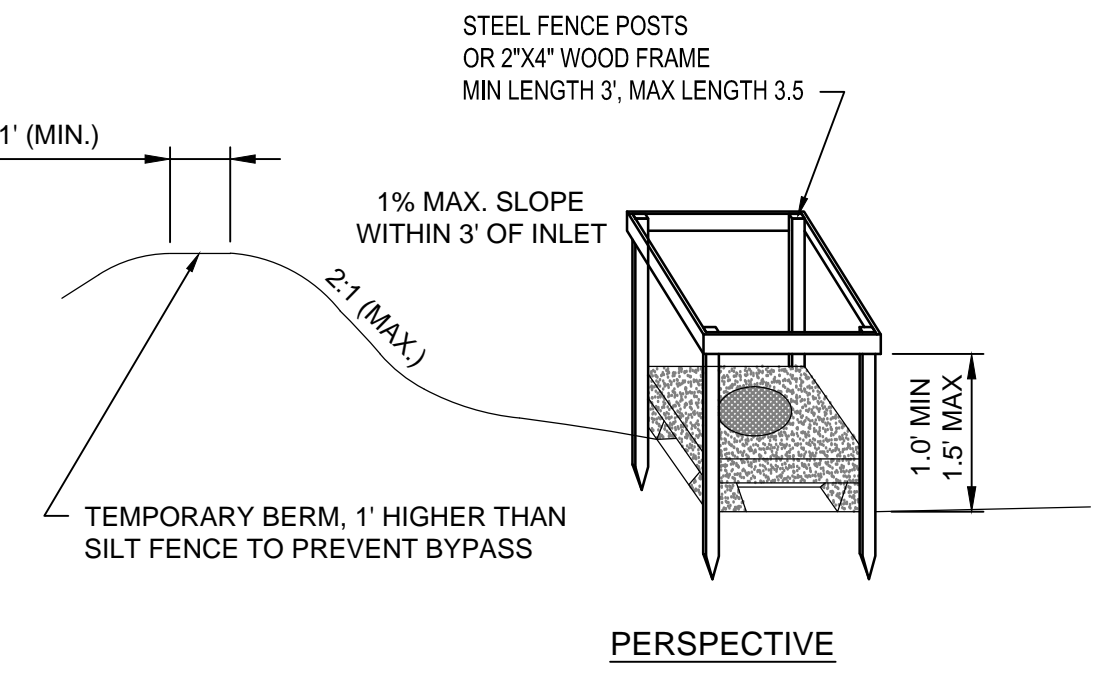

PROJECT SPECIFIC DETAIL
 INLET PROTECTION FABRIC DROP
 SCALE: N.T.S.

CITY OF O'FALLON
 ENGINEERING DEPARTMENT
 O'FALLON, MISSOURI

FANNING AVENUE
 STORM DRAINAGE
 IMPROVEMENTS

PRIMARY CONTACT
 CAROL J. ONEST, P.E.
 PHONE: 314.434.8898
 EMAIL: CAROLJONEST@KDCINC.COM

KDC
 Kuhlmann design Group, Inc.
 66 Progress Parkway
 St. Louis, Missouri 63043-3706
 Tel: 314.434.8898 Fax: 314.434.8280
 St. Louis, MO • Belleville, IL

KDC JOB #: 160031-0003



CITY OF O'FALLON
 100 NORTH MAIN STREET
 O'FALLON, MO 63366
 PH: (636) 379-5590
 E-MAIL: CCLERCY@O'FALLON.MO.US

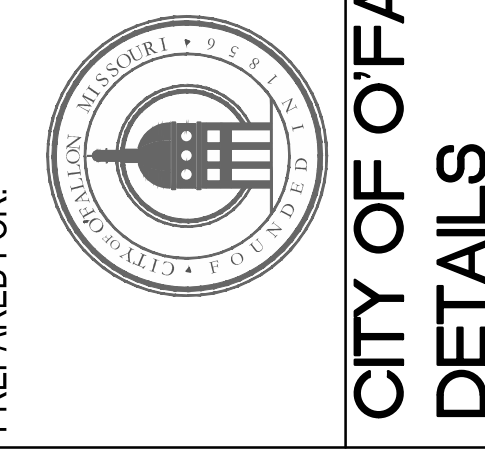

PREPARED FOR:
 City No.
 Page No.
 C4-01