

**FLUSHING HYDRANT DETAIL**  
NOT TO SCALE

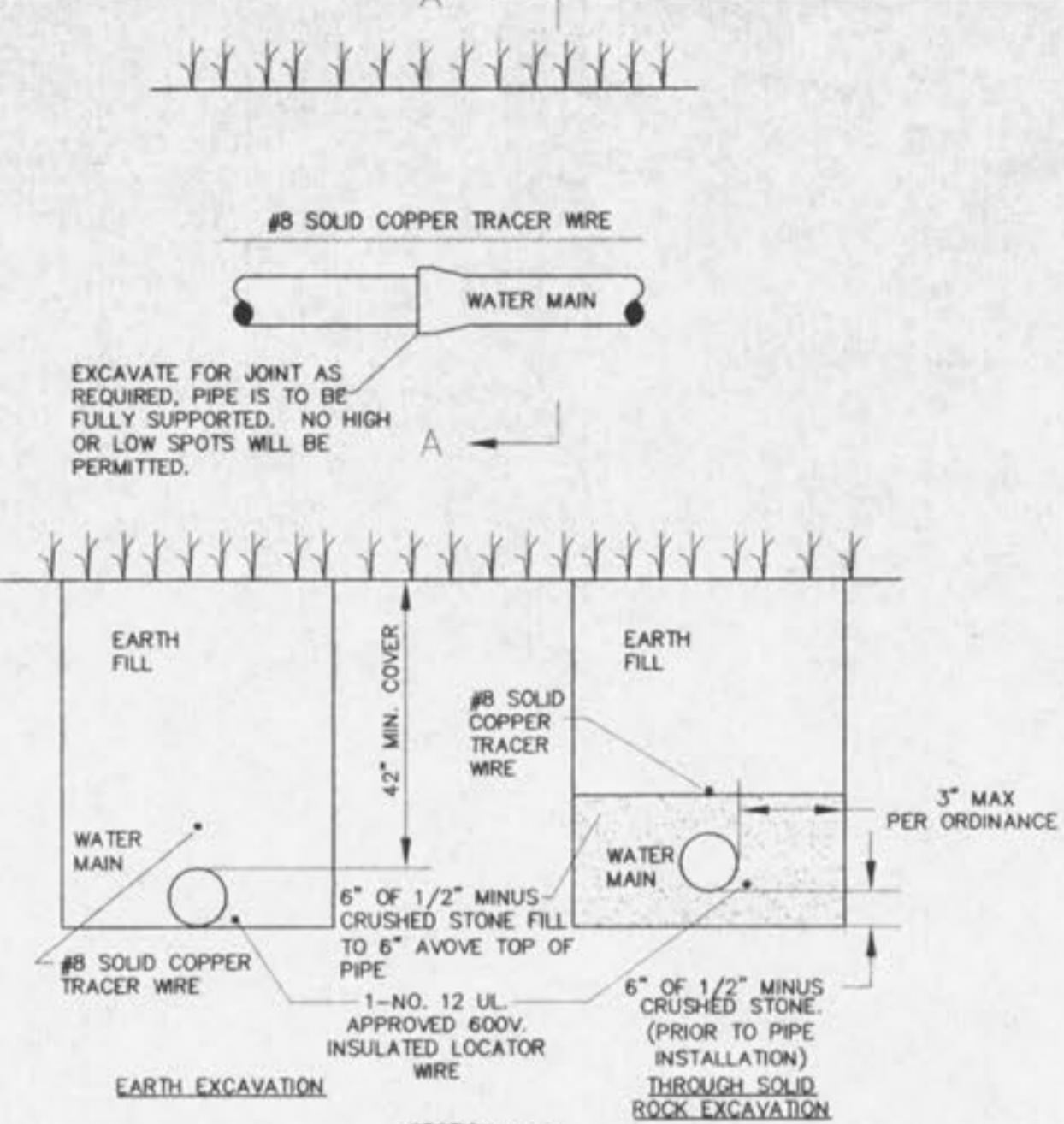

**TYPICAL WATER MAIN AND FIRE HYDRANT LOCATIONS**  
NOT TO SCALE

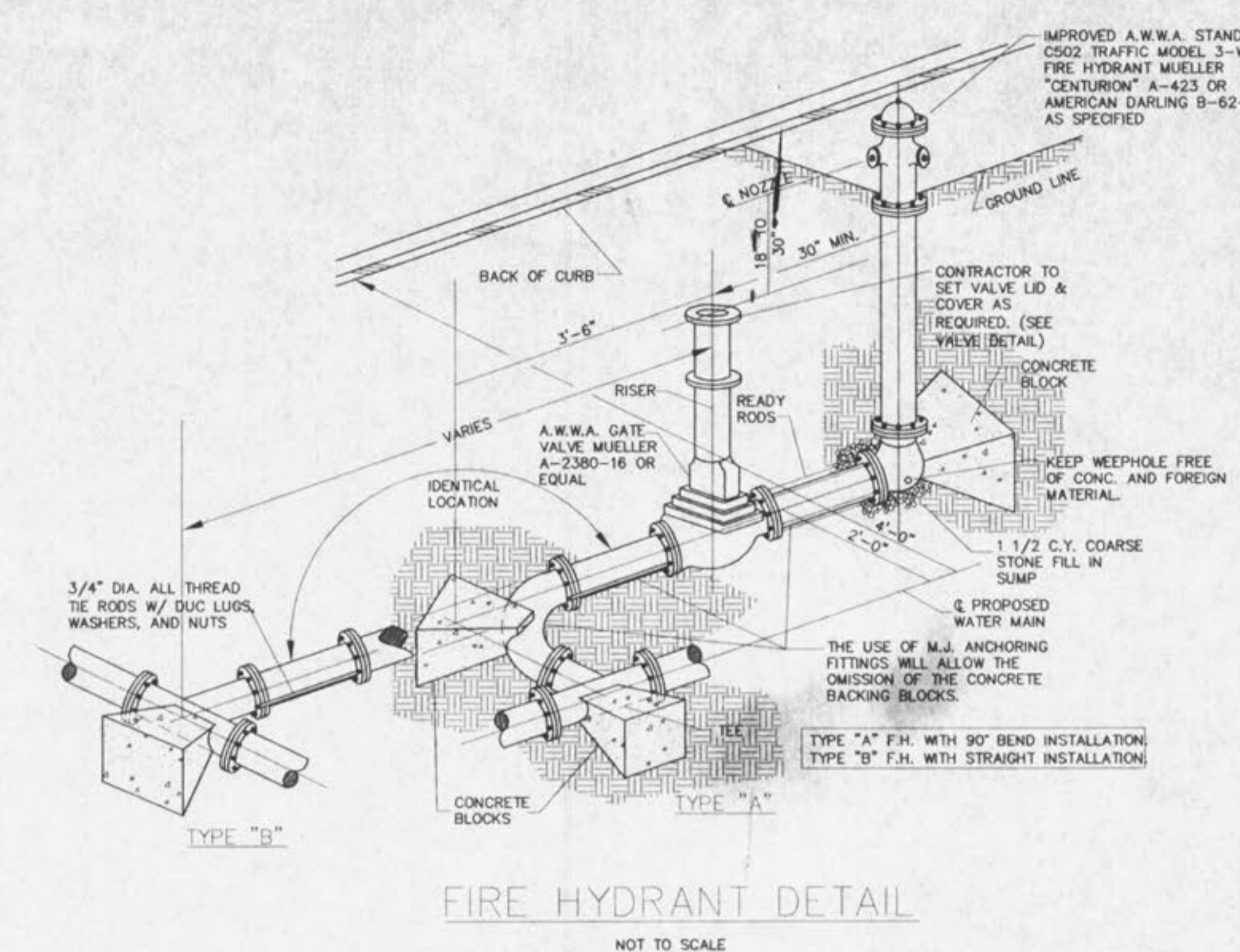

**FIRE HYDRANT DETAIL**  
NOT TO SCALE

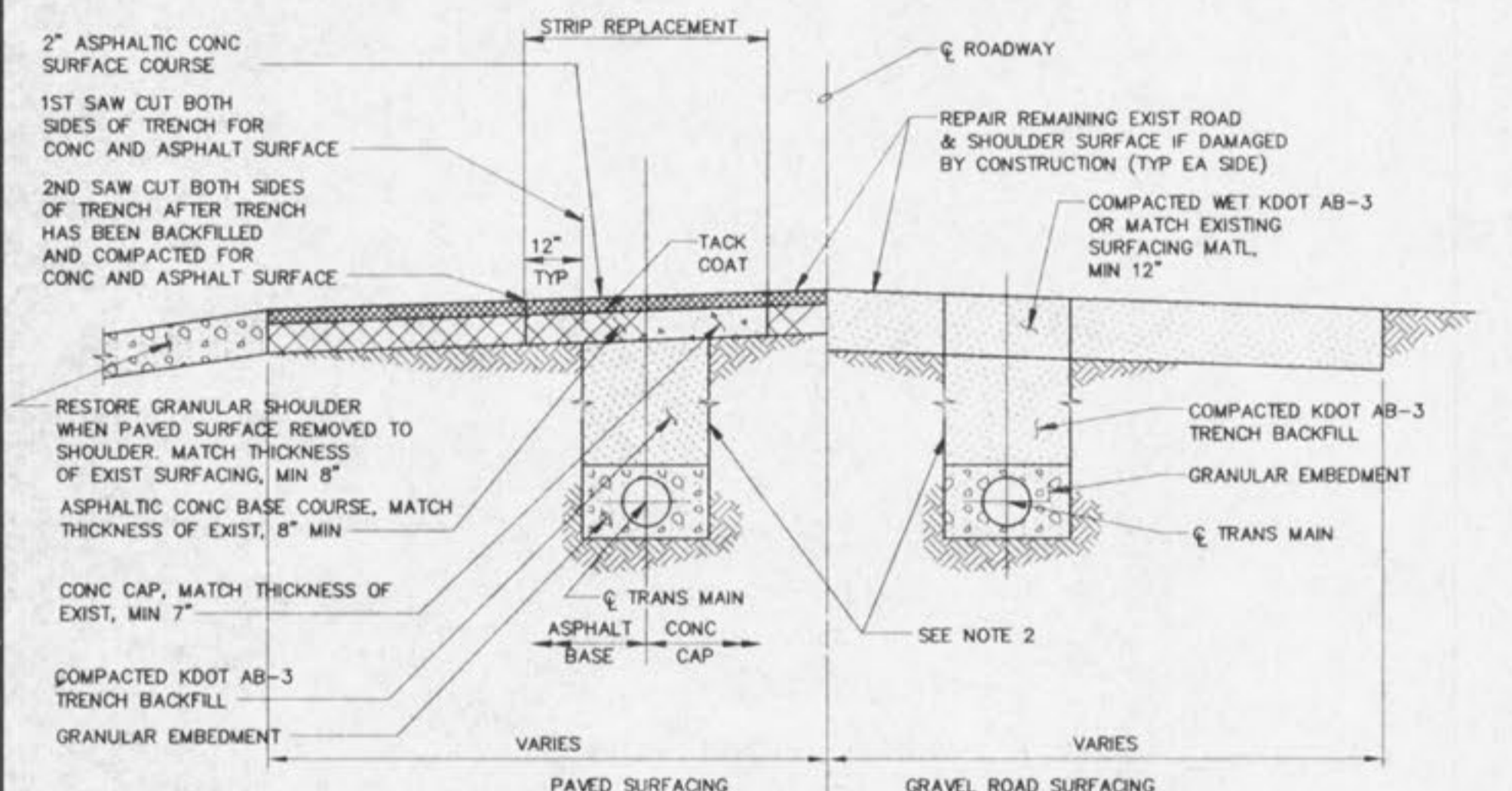

**STREET TRENCHING DETAIL AND CROSSING SECTION**  
NO SCALE

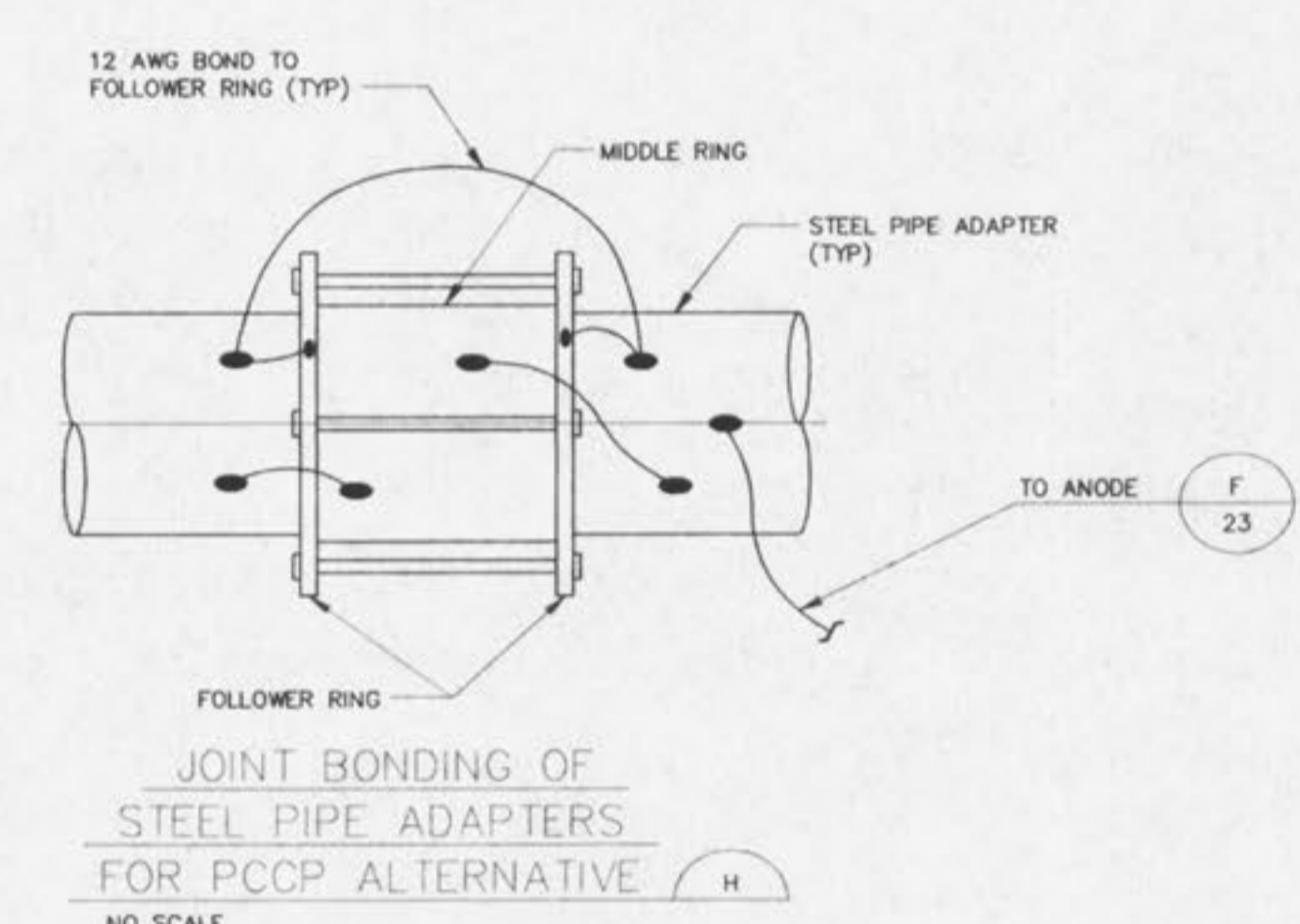

**JOINT BONDING OF STEEL PIPE ADAPTERS FOR PCCP ALTERNATIVE**  
NO SCALE

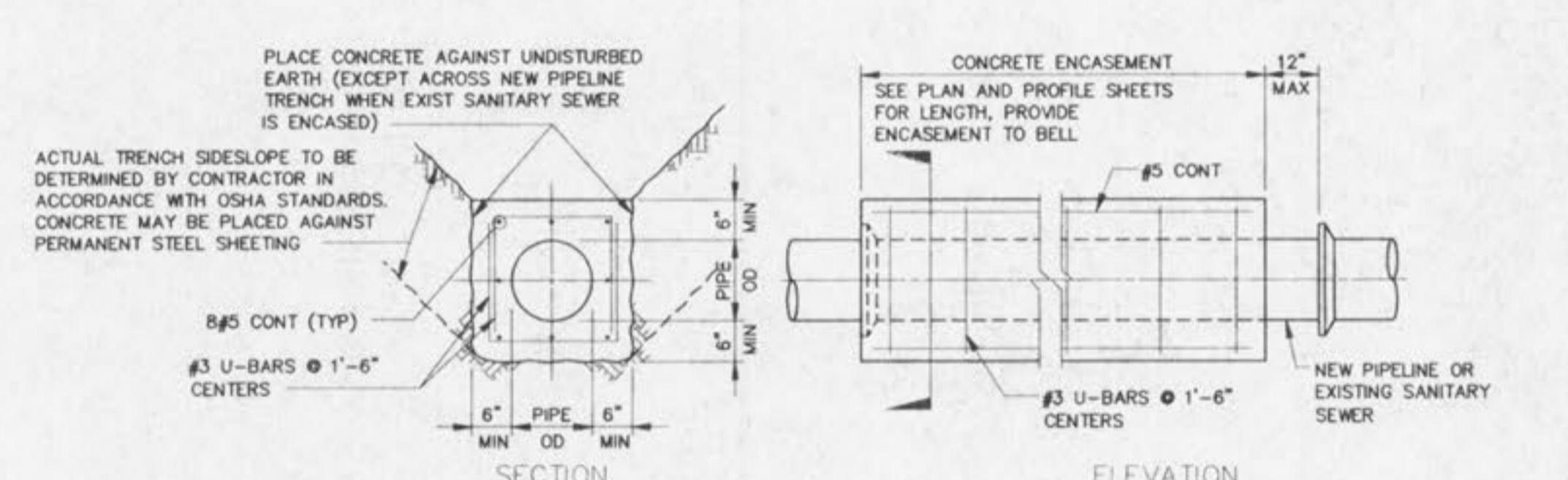

**CONCRETE ENCASUREMENT**  
NO SCALE

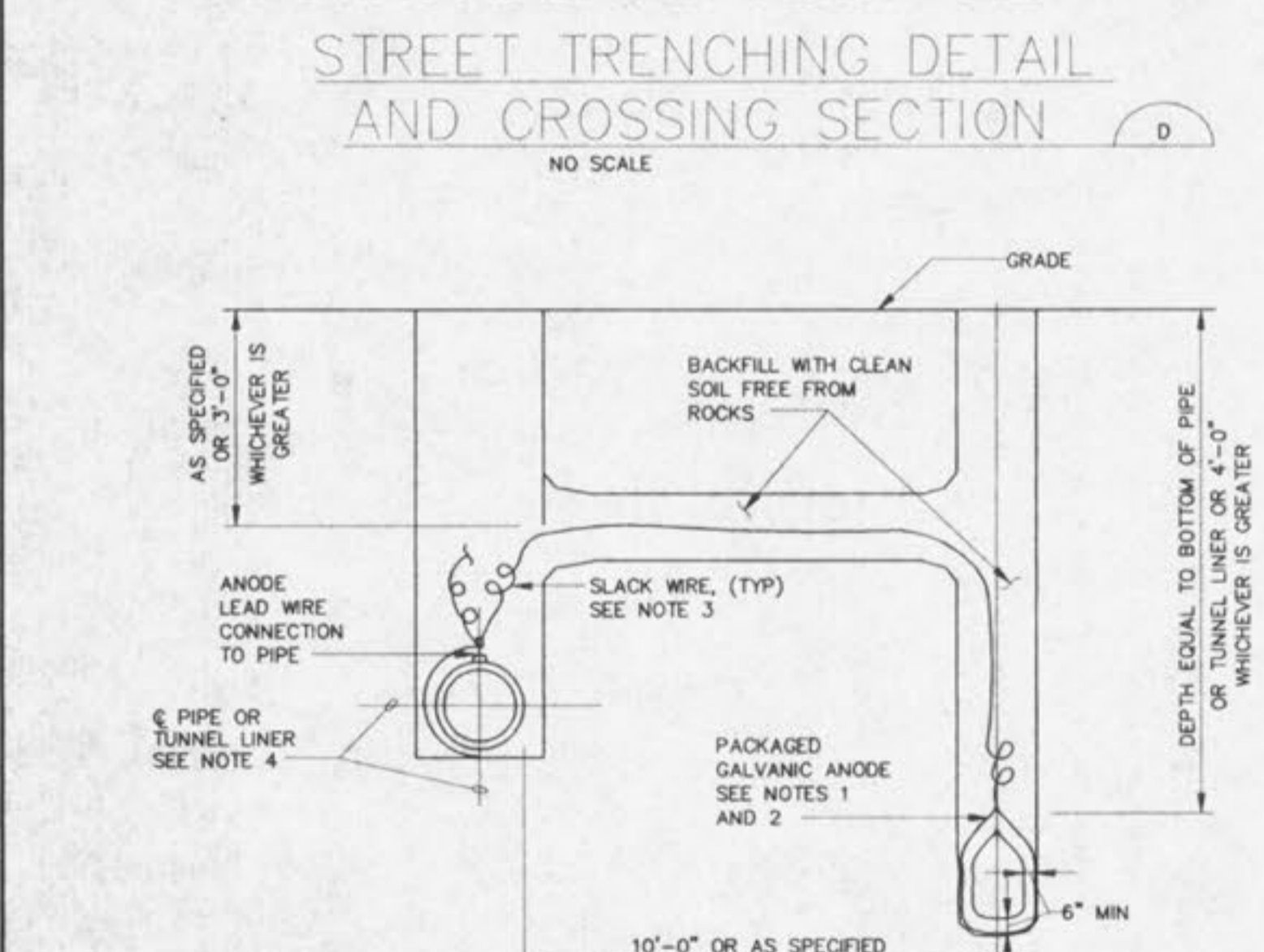

**ANODE INSTALLATION FOR STEEL PIPE ADAPTERS FOR PCCP ALTERNATIVE AND FOR TUNNEL LINERS**  
NO SCALE

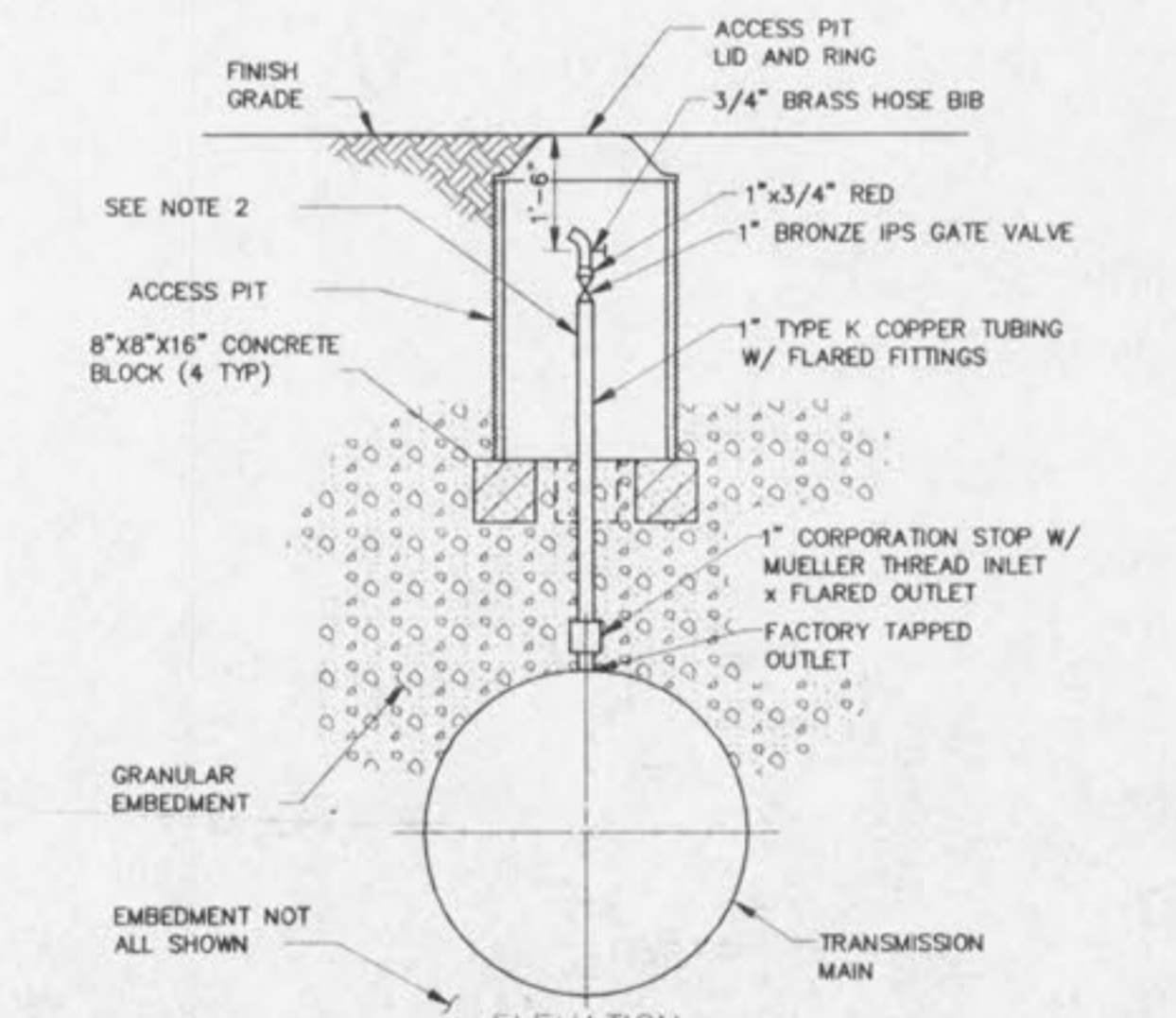

**MANUAL AIR RELEASE VALVE ASSEMBLY**  
NO SCALE

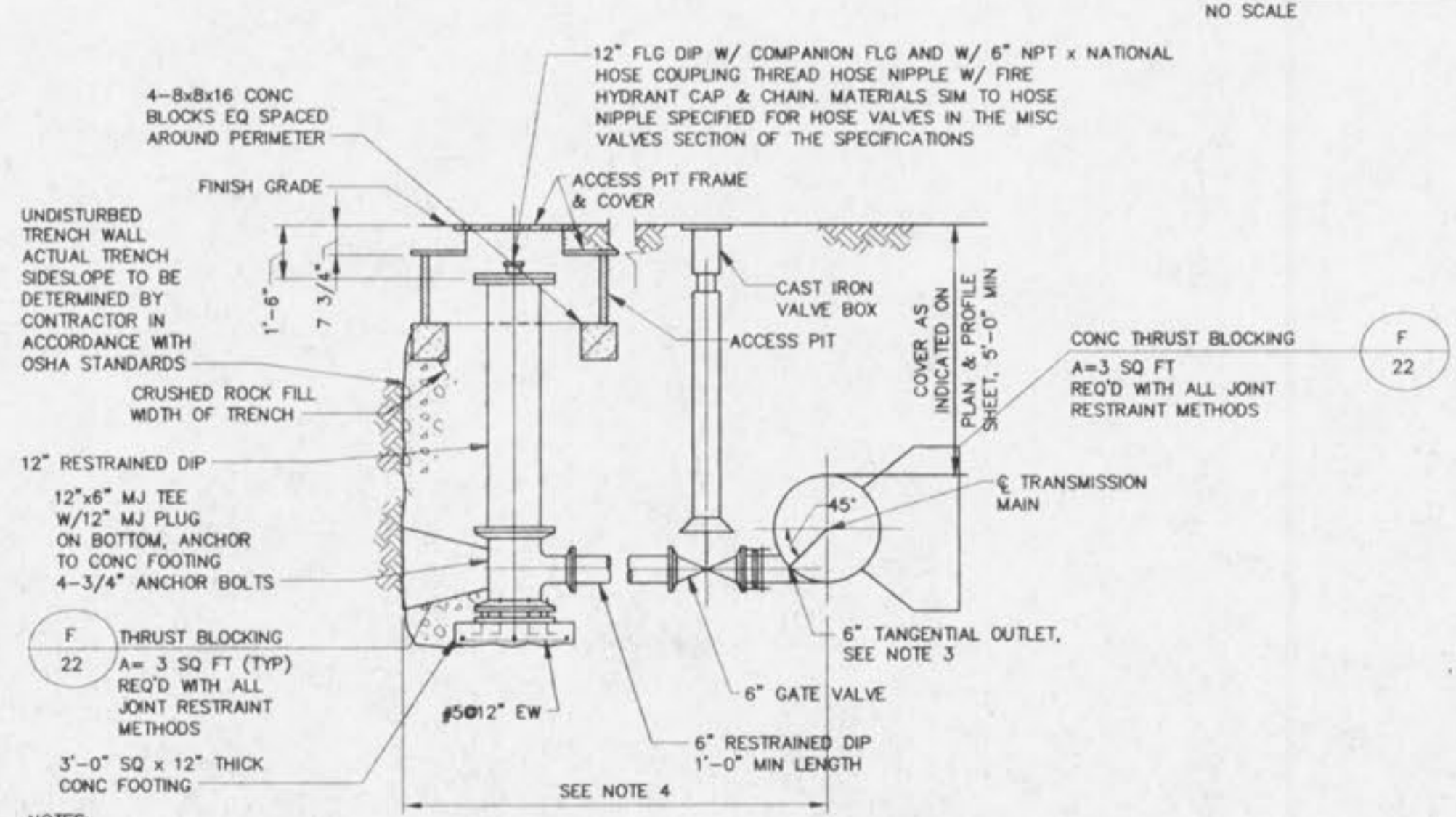

**BLOWOFF FACILITY**  
NO SCALE

**PICKETT RAY & SILVER**  
333 Mid Rivers Mall Drive  
St. Peters, MO 63376  
Phone (888) 397-1211  
Fax (888) 397-1104

**CIVIL ENGINEERS  
PLANNERS  
LAND SURVEYORS**

**HAMPTON WOODS**  
CONSTRUCTION DETAILS

Prepared For:  
**SUMMIT POINTE L.C.**

288 FOX HILL ROAD  
ST. CHARLES, MO 63301  
636-940-9350

REV. NO.	DATE	REV. BY	REV. BY	REV. BY	REV. BY
1	08-27-04	REV. PER CITY OF FALLON			
2	11-15-02	REV. PER CITY OF FALLON			

**ENGINEERS AUTHENTICATION**  
The responsibility for professional engineering liability on this project is hereby limited to the set of plans authorized by the seal, signature, and date hereunder attached. Responsibility is disclaimed for all other engineering plans involved in this project and specifically excludes revisions after this date unless reauthorized.

**PICKETT RAY & SILVER, INC.**

HAROLD J. BARRICK  
Professional Engineer  
No. 11111

DRAWN	DATE
ABK	10-23-02
CHECKED	DATE
D.W.D.	10-23-02
PROJECT #	95067.SUPO.00R
TASK #	4
FIELD BOOK	806