

**** NOTE **** - 3" depression in concrete is a concave surface. DO NOT construct with a linear sloping surface.
 - Maintain crown point and slope of adjacent road in the speed dip.

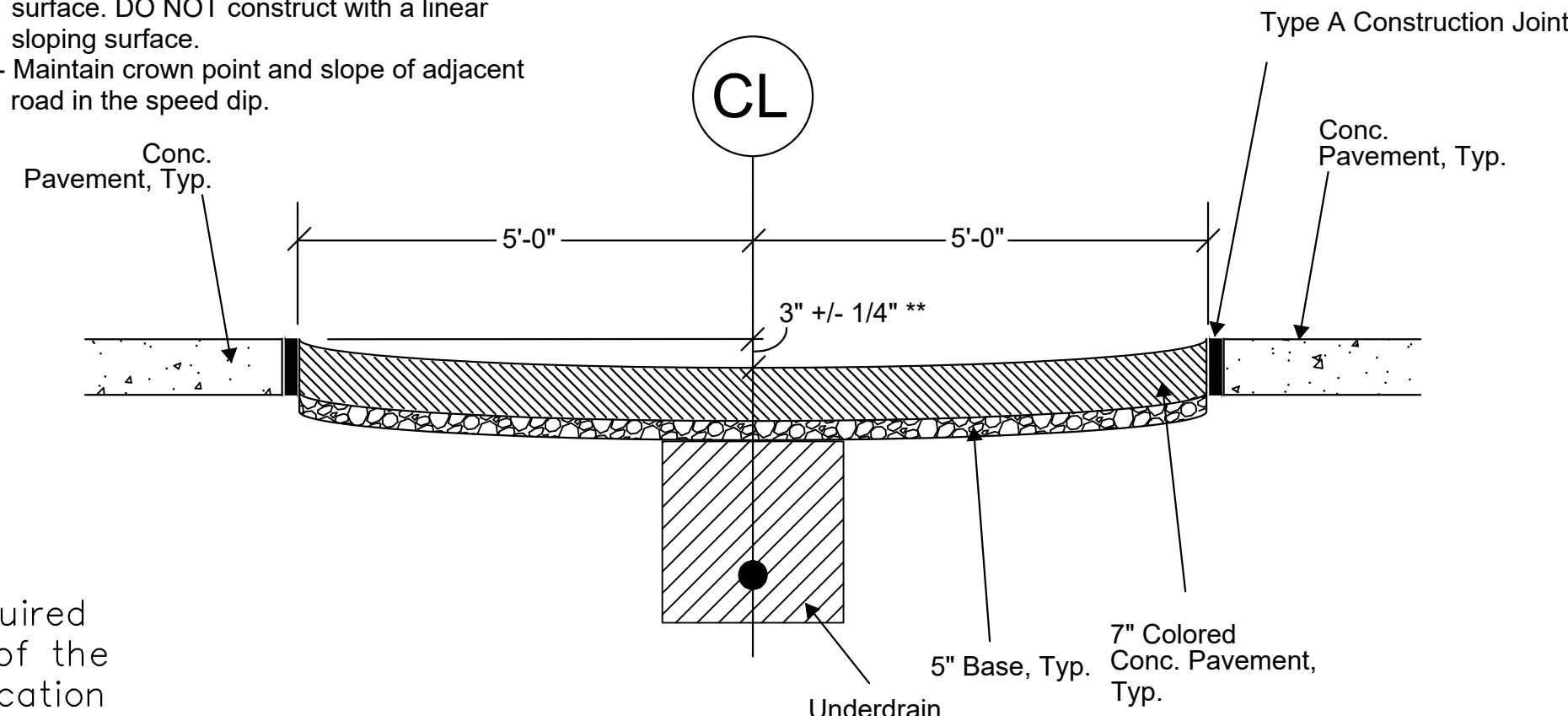

TRAFFIC CALMING 'DIP' - PROFILE VIEW

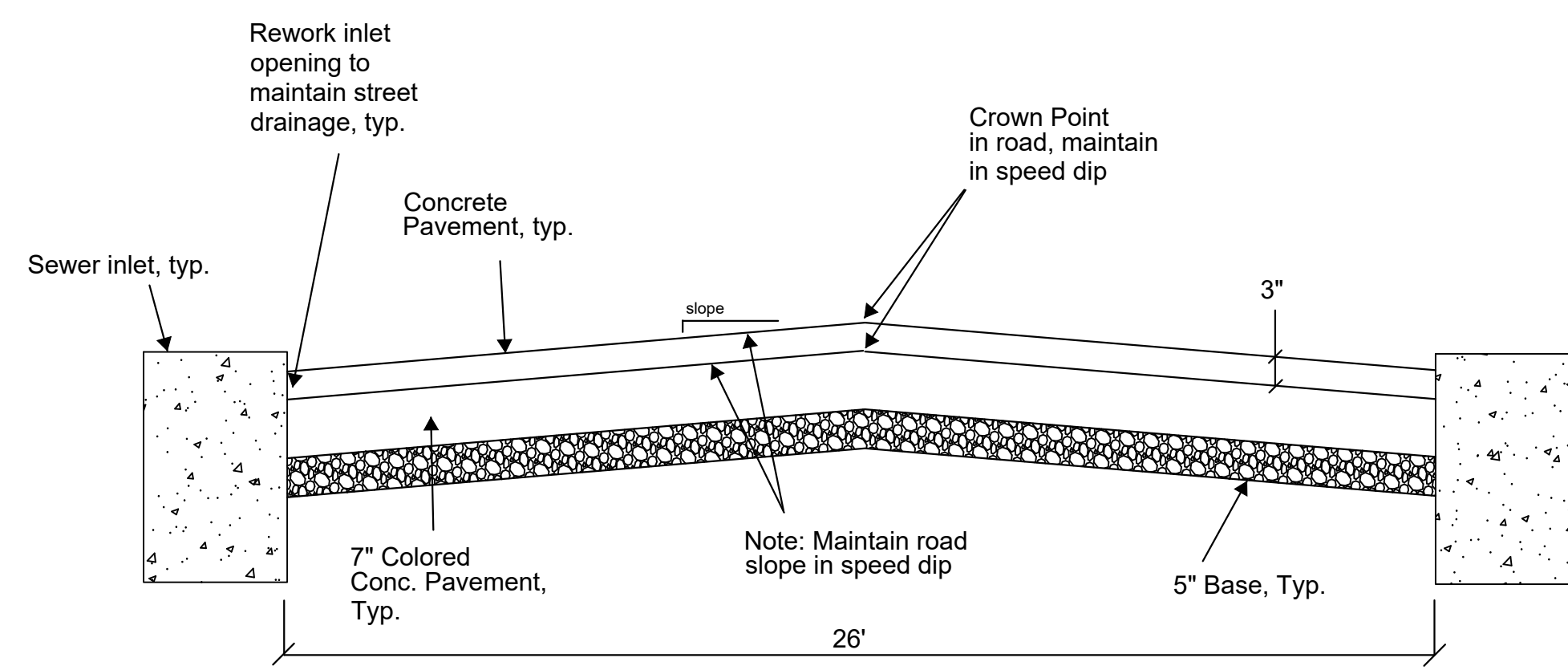

TRAFFIC CALMING 'DIP' - FRONT VIEW

ISSUE	REMARKS/DATE
1	2023-09-28, INITIAL SUBMITTAL
2	2024-02-01, CITY COMMENTS
3	2024-04-17, CITY COMMENTS
4	2024-05-20, FOR APPROVAL

'DIP' signs required on each side of the road at dip location

PROJECT TITLE

HARVEST AT HOPEWELL

O'Fallon, Missouri
O'FALLON PHASE IB

THE STERLING CO.
 ENGINEERS & SURVEYORS

6055 New Baumgartner Road
 St. Louis, Missouri 63129
 Ph 314-487-0440 Fax 314-487-8944
 www.sterling-eng-sur.com
 Corporate Certificate of Authority #001348

The Professional Engineer's seal and signature affixed to this plan shall constitute the seal and signature of the Engineer. The Engineer shall be responsible for the accuracy of the information provided on this plan and shall be liable for any errors or omissions. The Engineer shall not be responsible for any errors or omissions on the part of the client or any other party. The Engineer shall not be responsible for any errors or omissions on the part of any other party.



Date: 05-20-2024
 Michael G. Boerding
 License No. MO E-28643
 Professional Engineer

TYPICAL LOT DETAILS

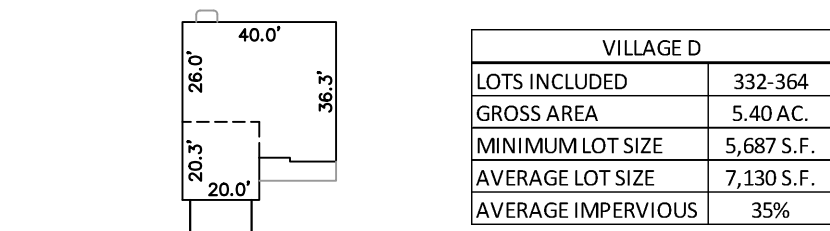

VILLAGE D	
LOTS INCLUDED	332-364
GROSS AREA	5.40 AC.
MINIMUM LOT SIZE	5,687 S.F.
AVERAGE LOT SIZE	7,130 S.F.
AVERAGE IMPERVIOUS	35%

TYPICAL HOUSE "D" LOT

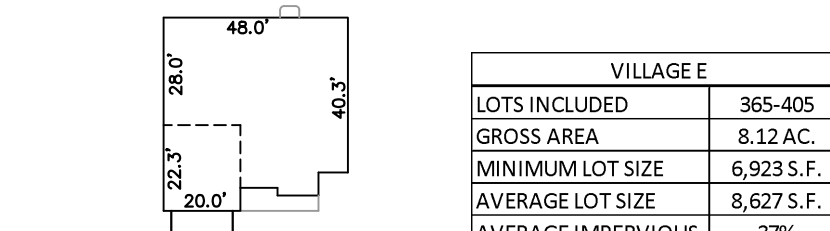

VILLAGE E	
LOTS INCLUDED	365-405
GROSS AREA	8.12 AC.
MINIMUM LOT SIZE	6,923 S.F.
AVERAGE LOT SIZE	8,627 S.F.
AVERAGE IMPERVIOUS	37%

TYPICAL HOUSE "E" LOT

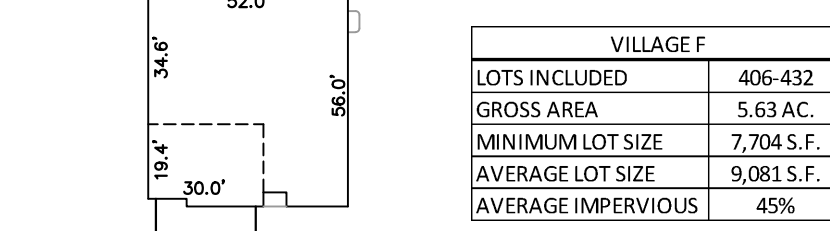

VILLAGE F	
LOTS INCLUDED	406-432
GROSS AREA	5.63 AC.
MINIMUM LOT SIZE	7,704 S.F.
AVERAGE LOT SIZE	9,081 S.F.
AVERAGE IMPERVIOUS	45%

TYPICAL HOUSE "F" LOT

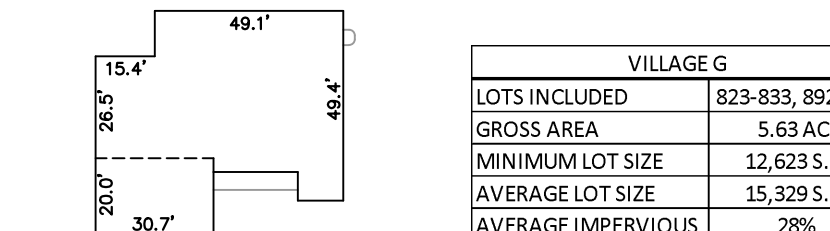

VILLAGE G	
LOTS INCLUDED	823-833, 892-896
GROSS AREA	5.63 AC.
MINIMUM LOT SIZE	12,623 S.F.
AVERAGE LOT SIZE	15,329 S.F.
AVERAGE IMPERVIOUS	28%

TYPICAL HOUSE "G" LOT

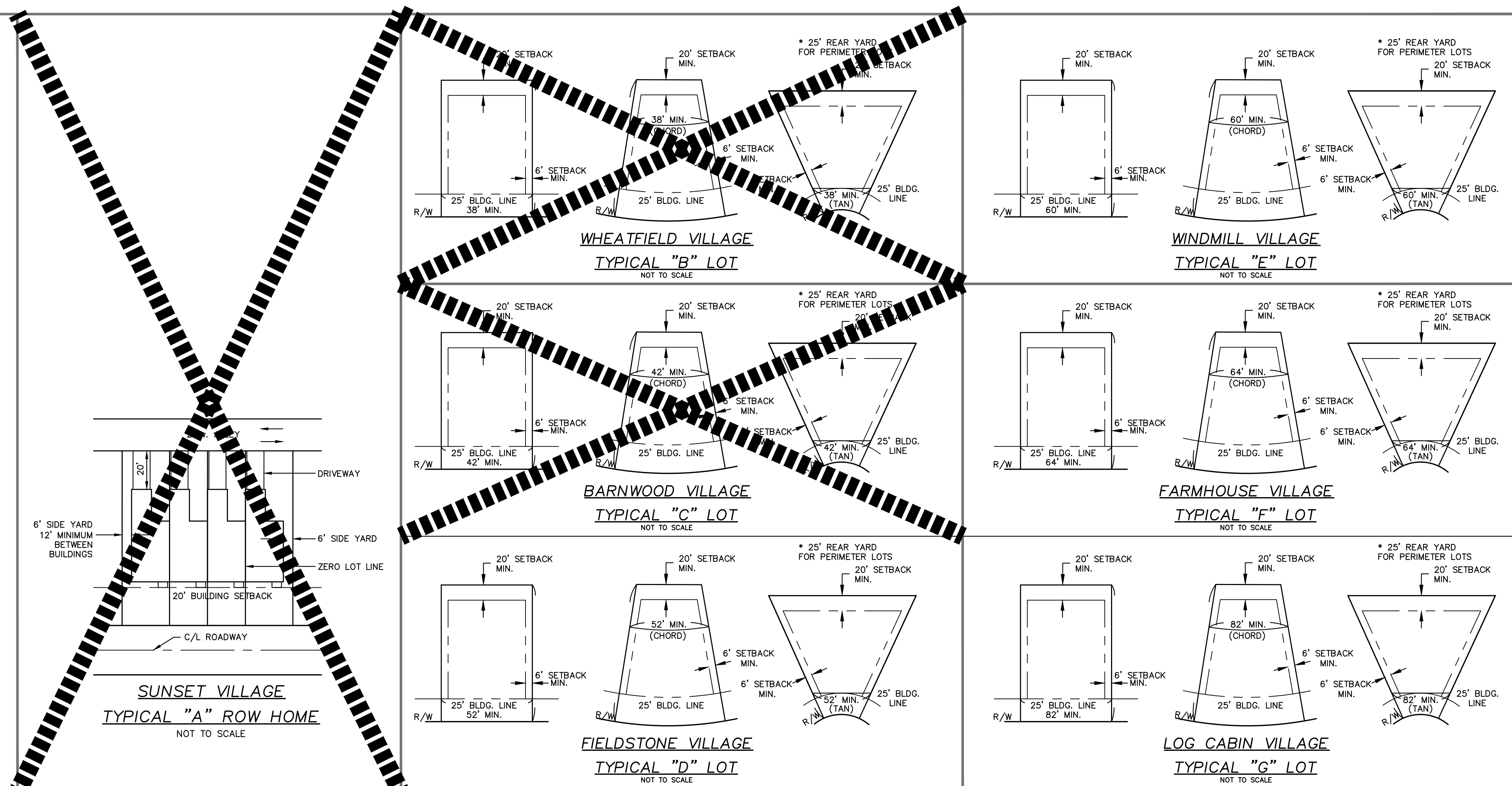

HARVEST HOPEWELL, LLC
 5091 New Baumgartner Road
 St. Louis, Missouri 63129

PAVEMENT DETAILS

P+Z No. 21-004994
 City No. 21-011444
 Date: 05-20-2024
 Job No. 20-09-327

Page No.

DTL-11.1
 IMP

Drawing name: V:\20090227 Highway N Acropolis\Drawings\Engineering\Improvements\9227 IMP DETAILS.dwg, Plotted on: May 20, 2024 - 10:26am, Plotted by: jandreaus