

PRE-CAST CONCRETE UNIT FOR SINGLE STREET INLET  
METROPOLITAN ST. LOUIS SEWER DISTRICT  
Standard Details of Sewer Construction  
Dr. W.S.H. Ch. J.C.K. 1992 SHEET 37

PRE-CAST CONCRETE UNIT FOR 4 WAY AREA INLET  
METROPOLITAN ST. LOUIS SEWER DISTRICT  
Standard Details of Sewer Construction  
Dr. D.A.B. Ch. J.C.K. 1992 SHEET 38

CONCRETE DOUBLE STREET INLET W/PRE CAST CONCRETE UNIT A  
METROPOLITAN ST. LOUIS SEWER DISTRICT  
Standard Details of Sewer Construction  
Dr. R.C.W. Ch. J.C.K. 1992 SHEET 39

PRE-CAST CONCRETE UNIT A FOR STREET DOUBLE INLET  
METROPOLITAN ST. LOUIS SEWER DISTRICT  
Standard Details of Sewer Construction  
Dr. R.C.W. Ch. J.C.K. 1992 SHEET 40

PRE-CAST CONCRETE UNIT B FOR STREET DOUBLE INLET  
METROPOLITAN ST. LOUIS SEWER DISTRICT  
Standard Details of Sewer Construction  
Dr. R.C.W. Ch. J.C.K. 1992 SHEET 41

STANDARD - INLET STONES, BLOCKS & DESIGN DETAILS  
METROPOLITAN ST. LOUIS SEWER DISTRICT  
Standard Details of Sewer Construction  
Dr. W.S.H. Ch. J.C.K. 1992 SHEET 42

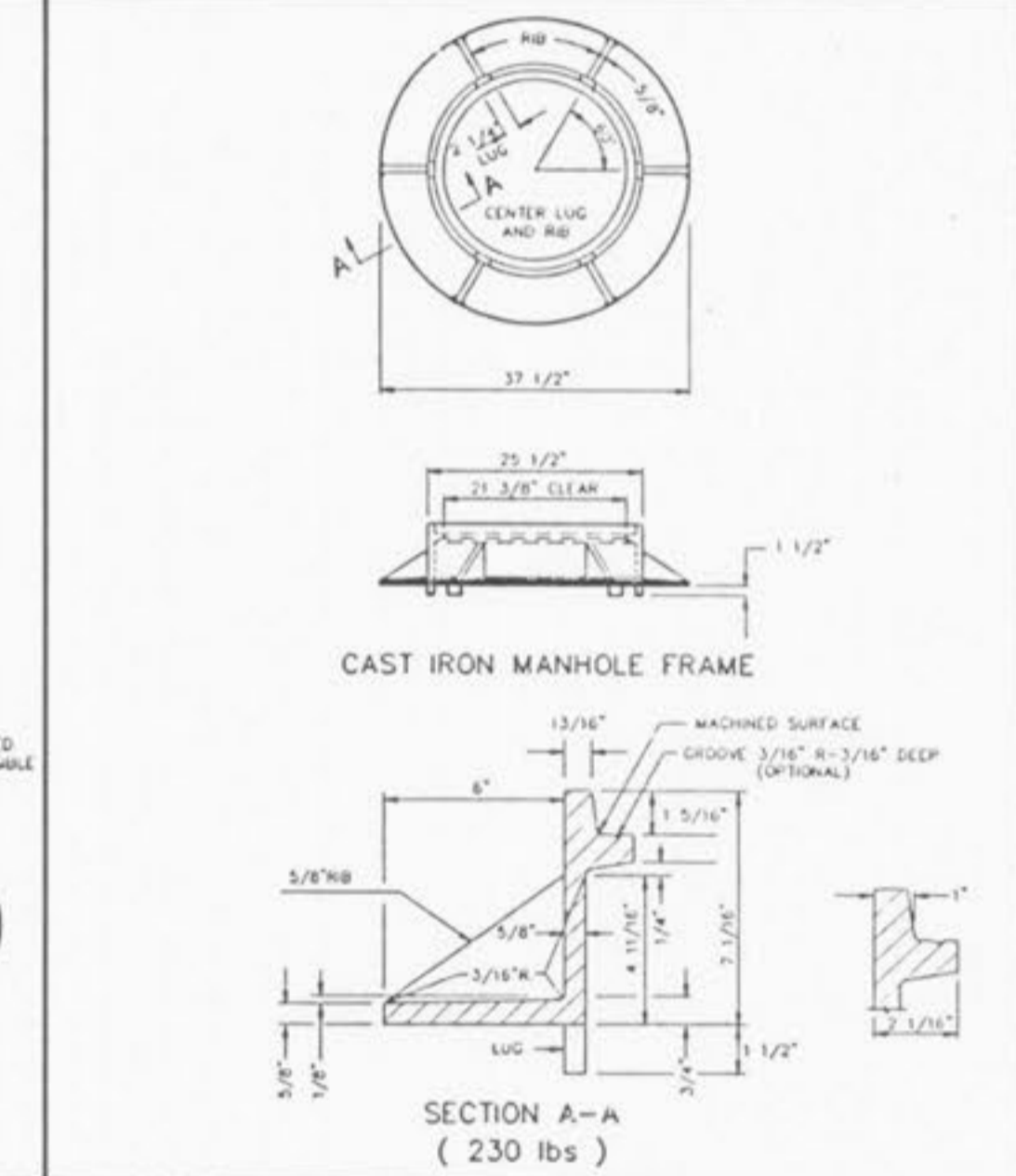
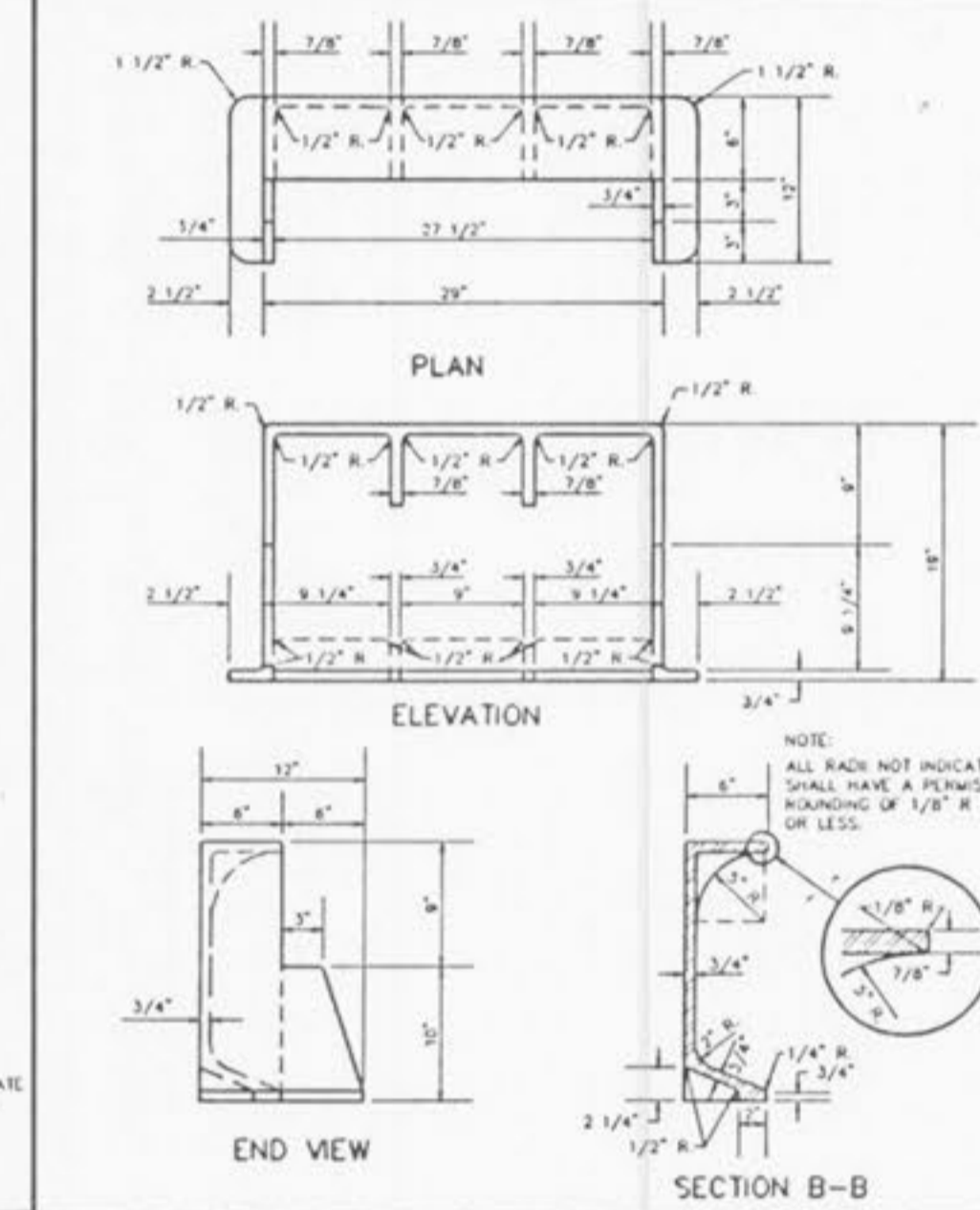
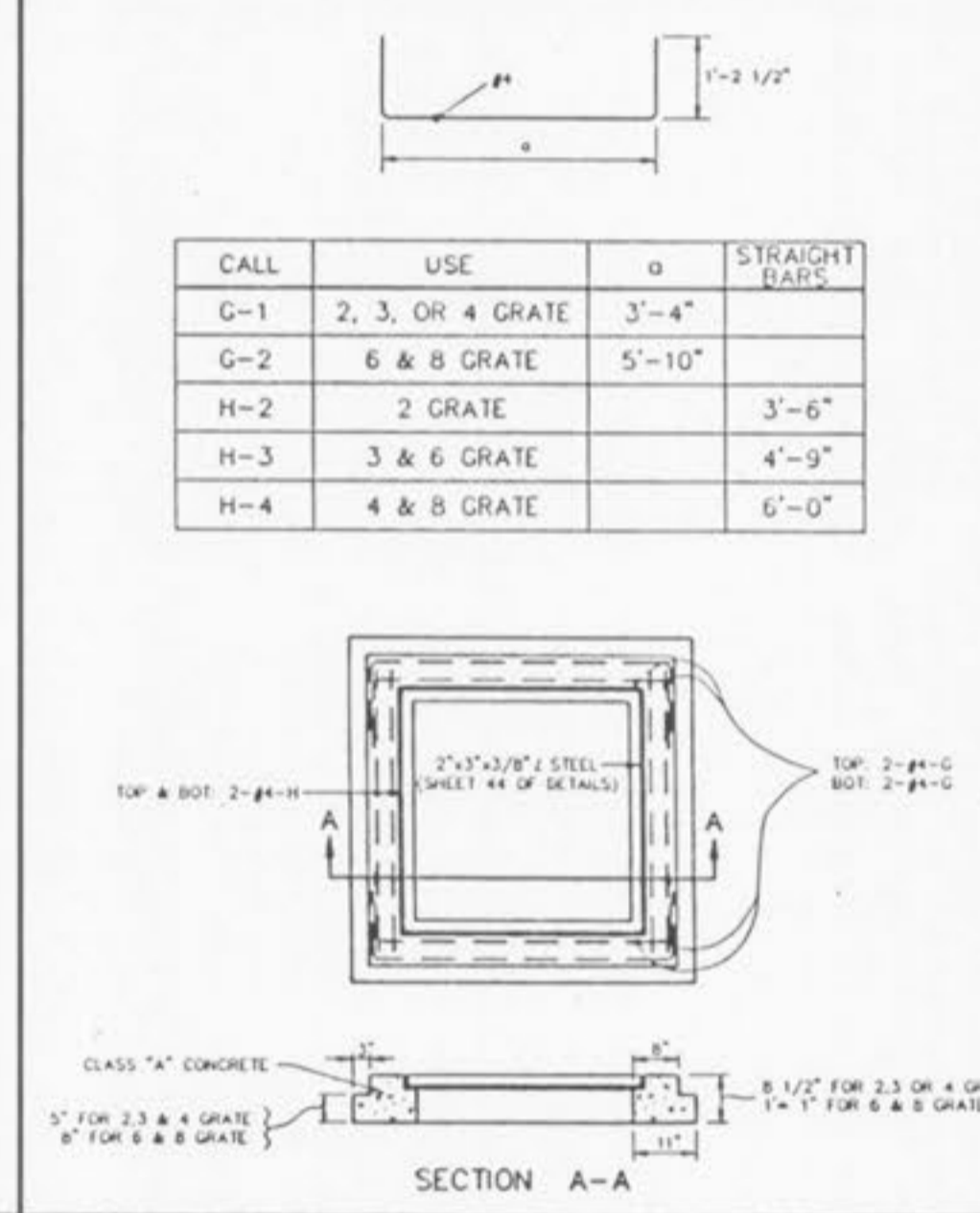
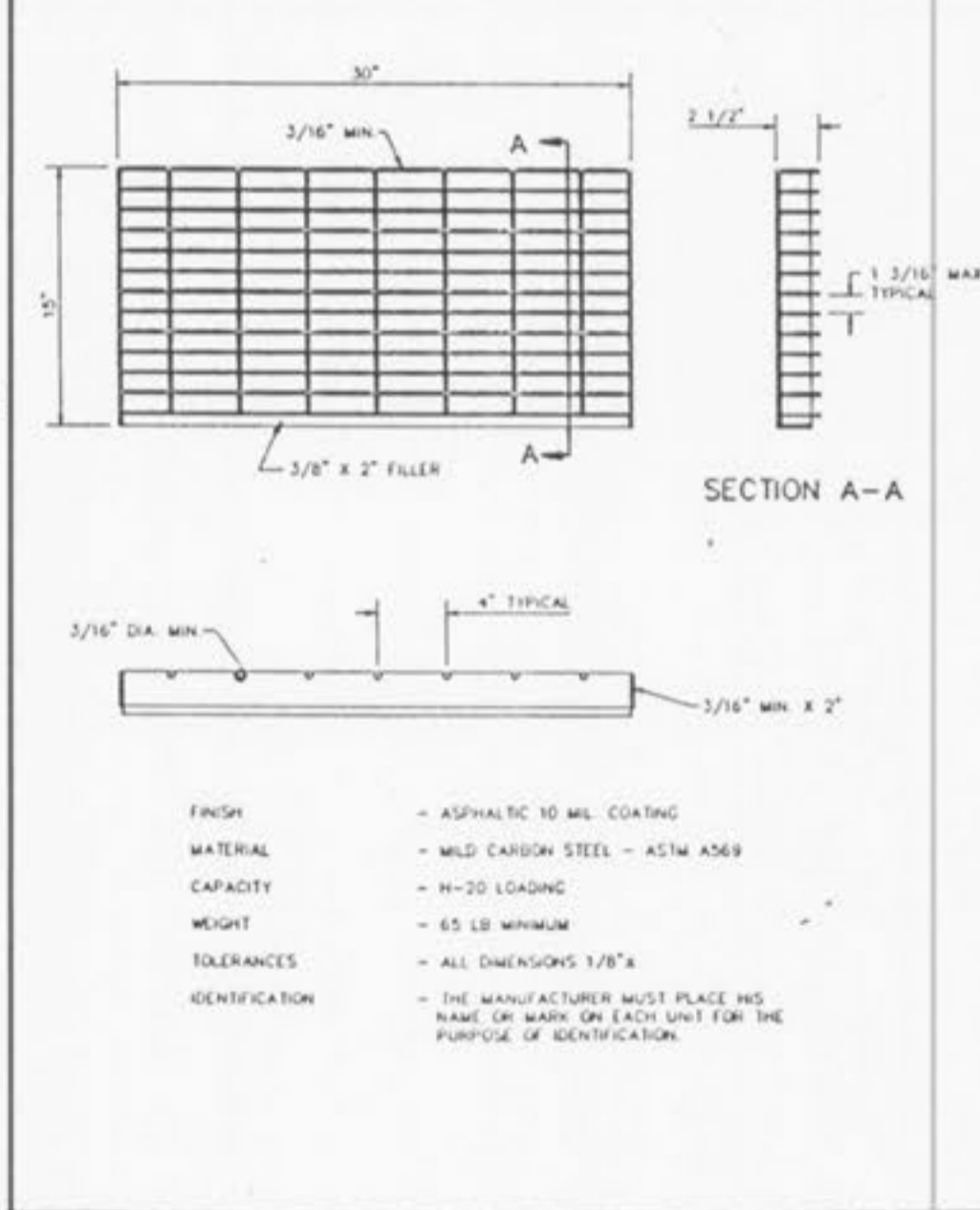
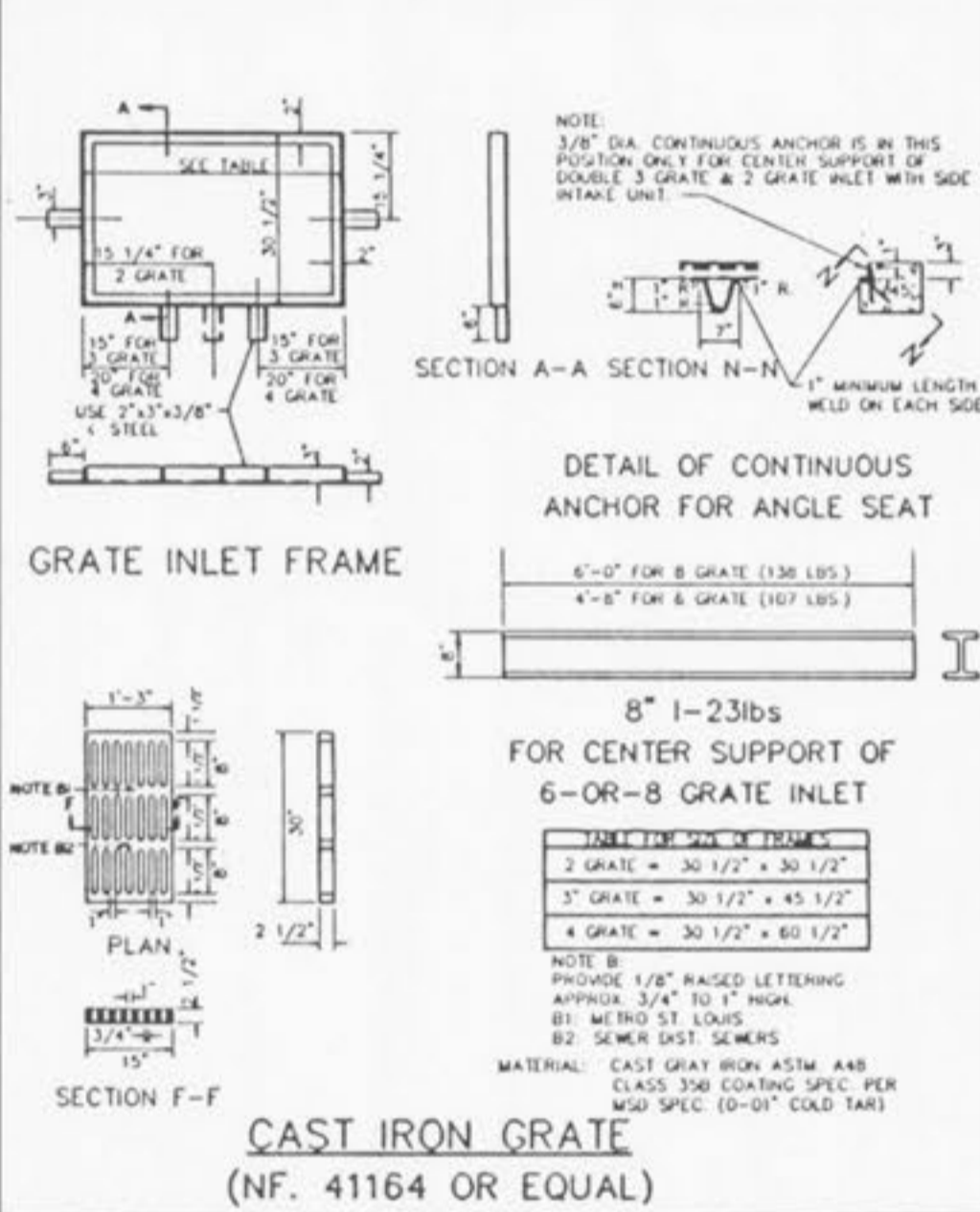
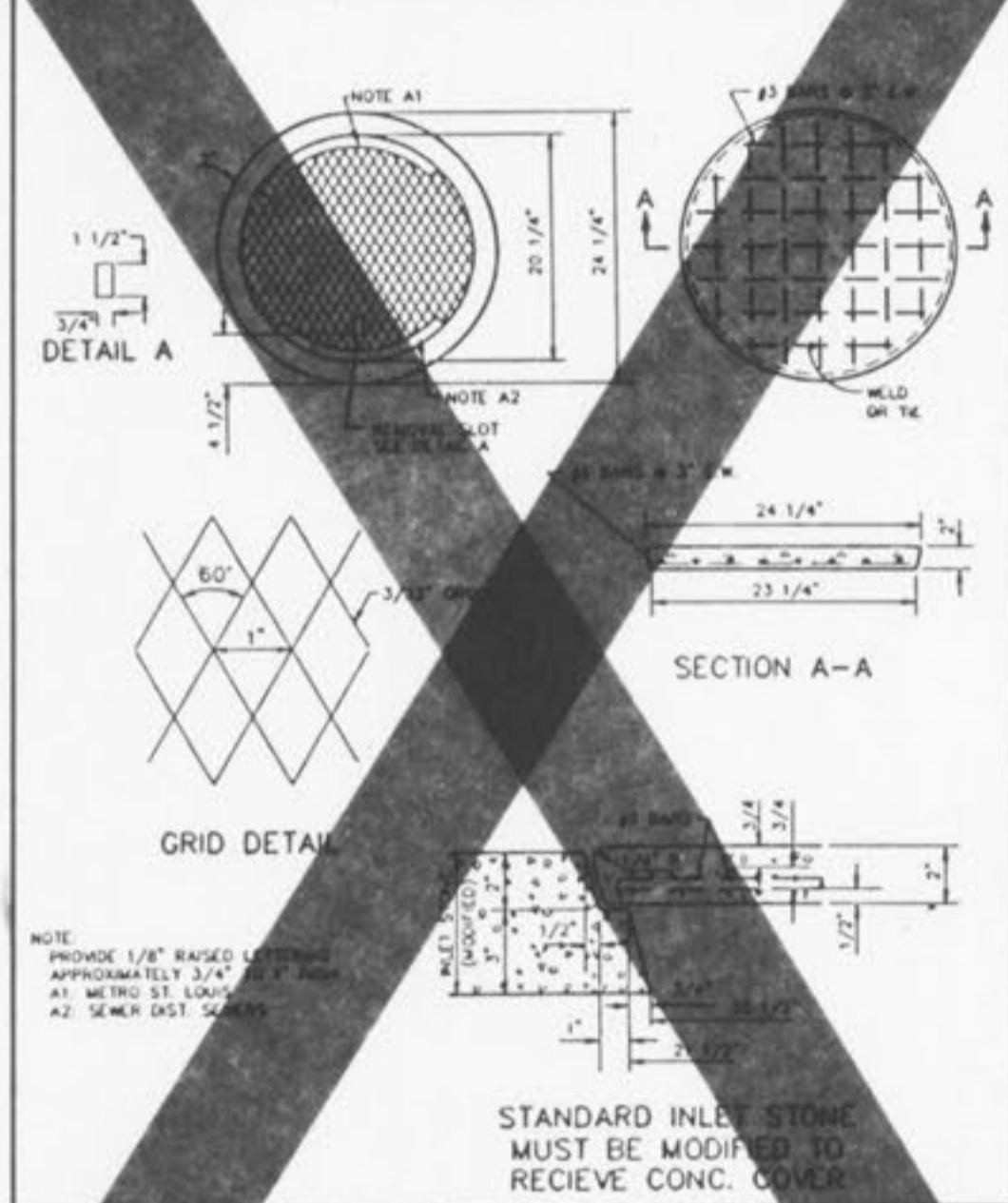

PRE-CAST CONCRETE INLET COVER  
METROPOLITAN ST. LOUIS SEWER DISTRICT  
Standard Details of Sewer Construction  
Dr. R.C.W. Ch. J.C.K. 1992 SHEET 43

DETAILS OF INLET FRAME AND GRATES  
METROPOLITAN ST. LOUIS SEWER DISTRICT  
Standard Details of Sewer Construction  
Dr. R.C.W. Ch. J.C.K. 1992 SHEET 44

DETAIL OF STEEL GRATE  
METROPOLITAN ST. LOUIS SEWER DISTRICT  
Standard Details of Sewer Construction  
Dr. R.C.W. Ch. J.C.K. 1992 SHEET 45

STEEL REQUIREMENTS FOR GRATE INLET SEAT  
METROPOLITAN ST. LOUIS SEWER DISTRICT  
Standard Details of Sewer Construction  
Dr. W.S.H. Ch. J.C.K. 1992 SHEET 46

CAST IRON SIDE INTAKE UNIT FOR GRATED INLETS 249 LBS.  
METROPOLITAN ST. LOUIS SEWER DISTRICT  
Standard Details of Sewer Construction  
Dr. R.C.W. Ch. J.C.K. 1992 SHEET 47

CAST IRON MANHOLE FRAME  
METROPOLITAN ST. LOUIS SEWER DISTRICT  
Standard Details of Sewer Construction  
Dr. D.A.B. Ch. J.C.K. 1992 SHEET 48

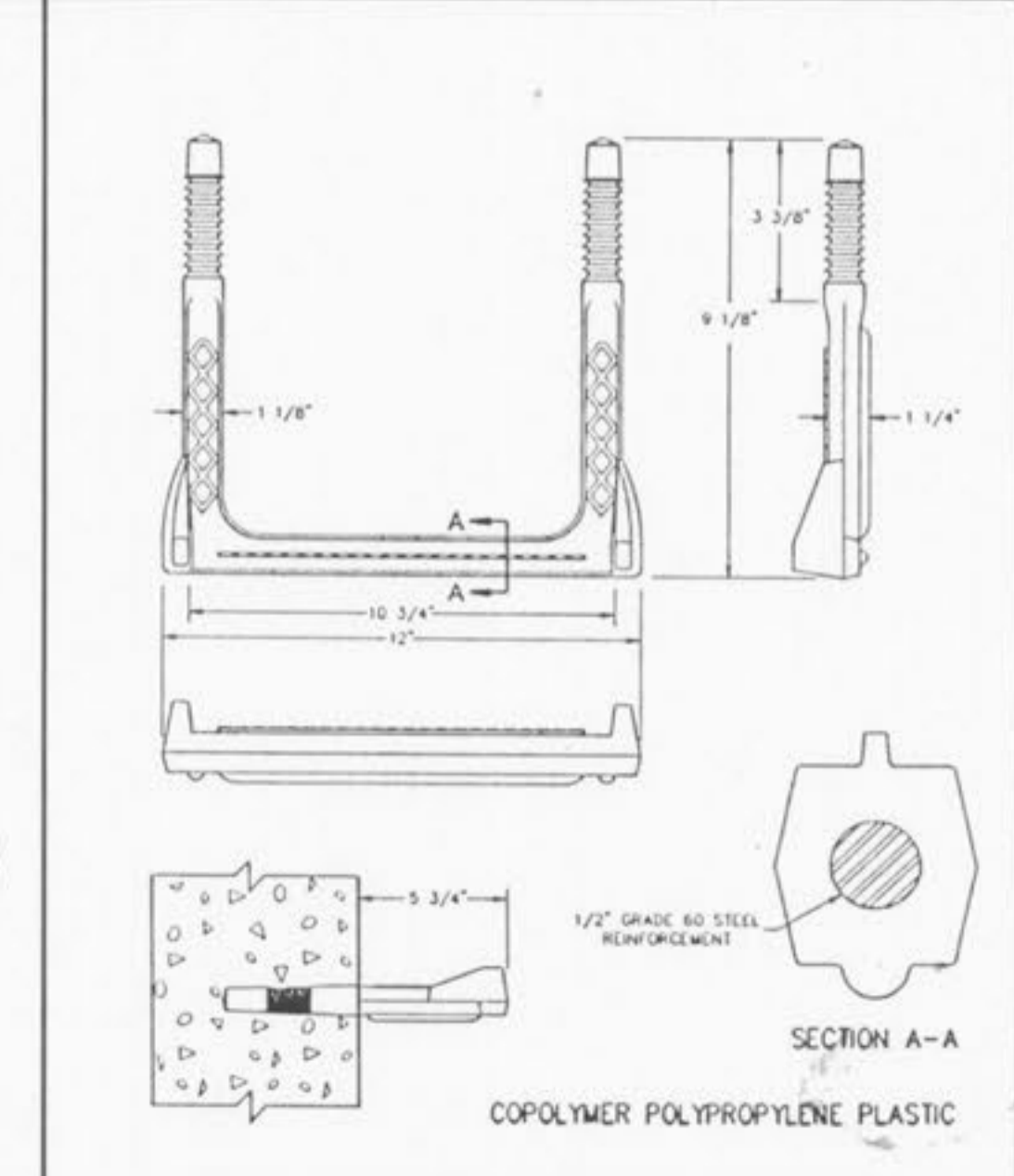
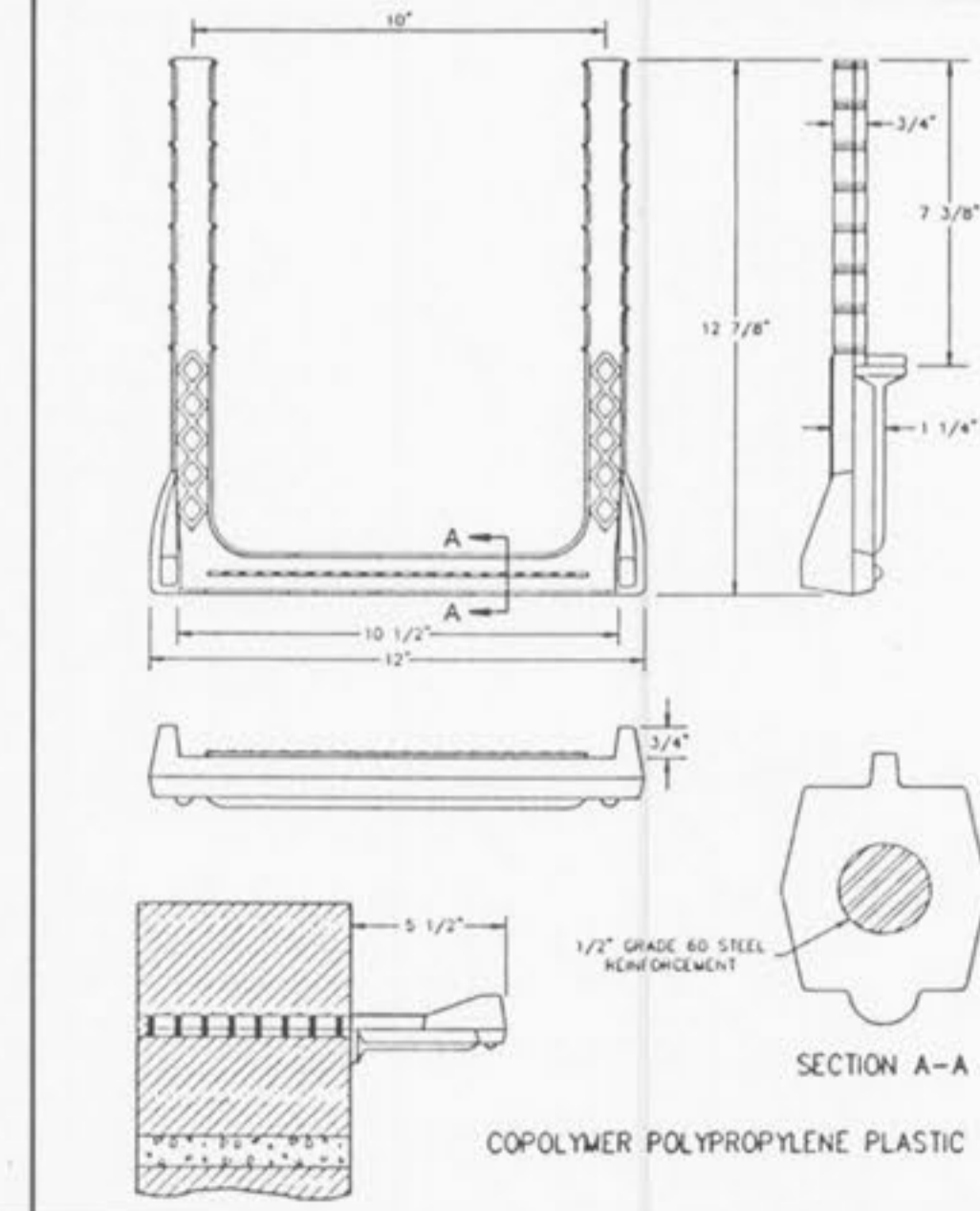
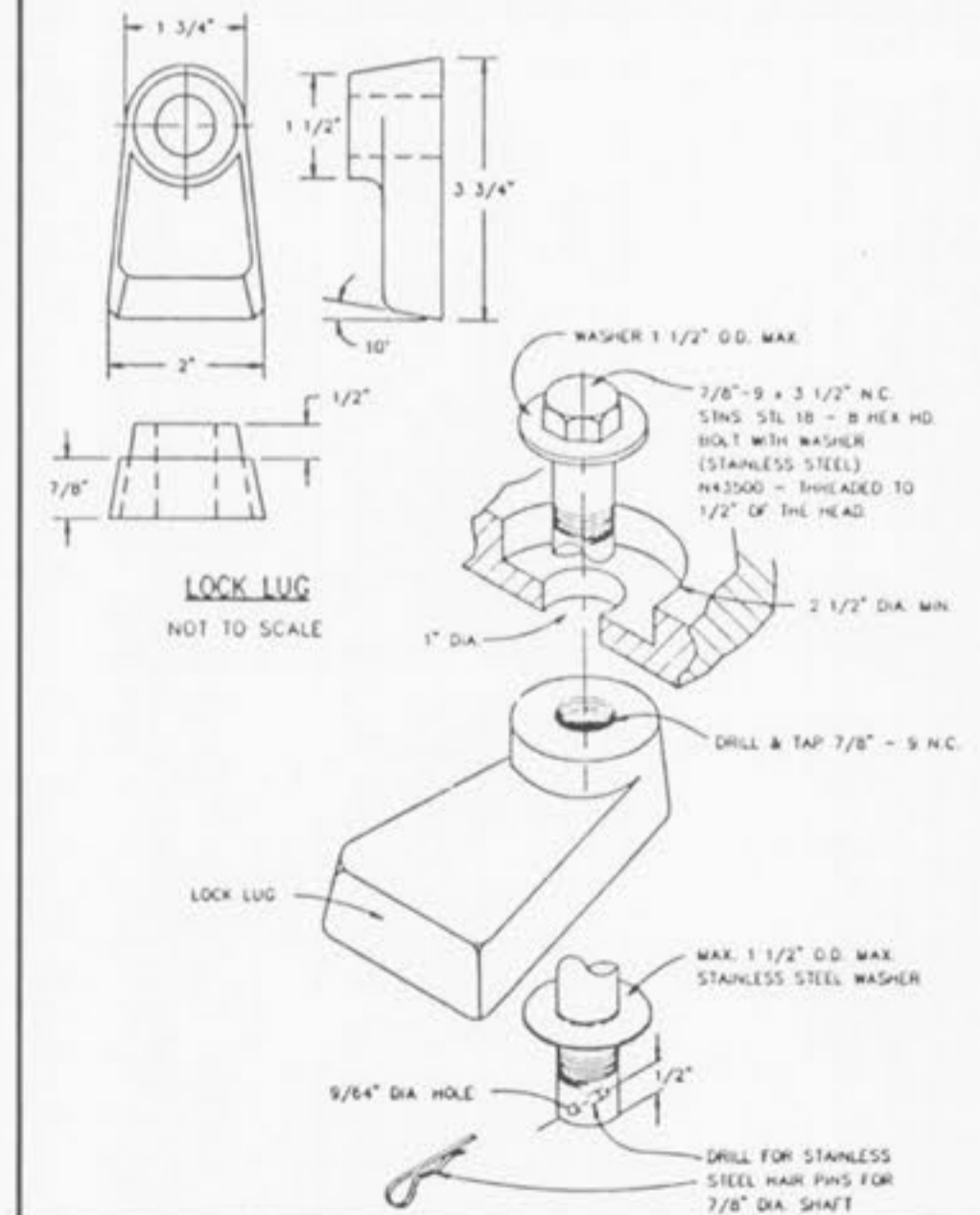
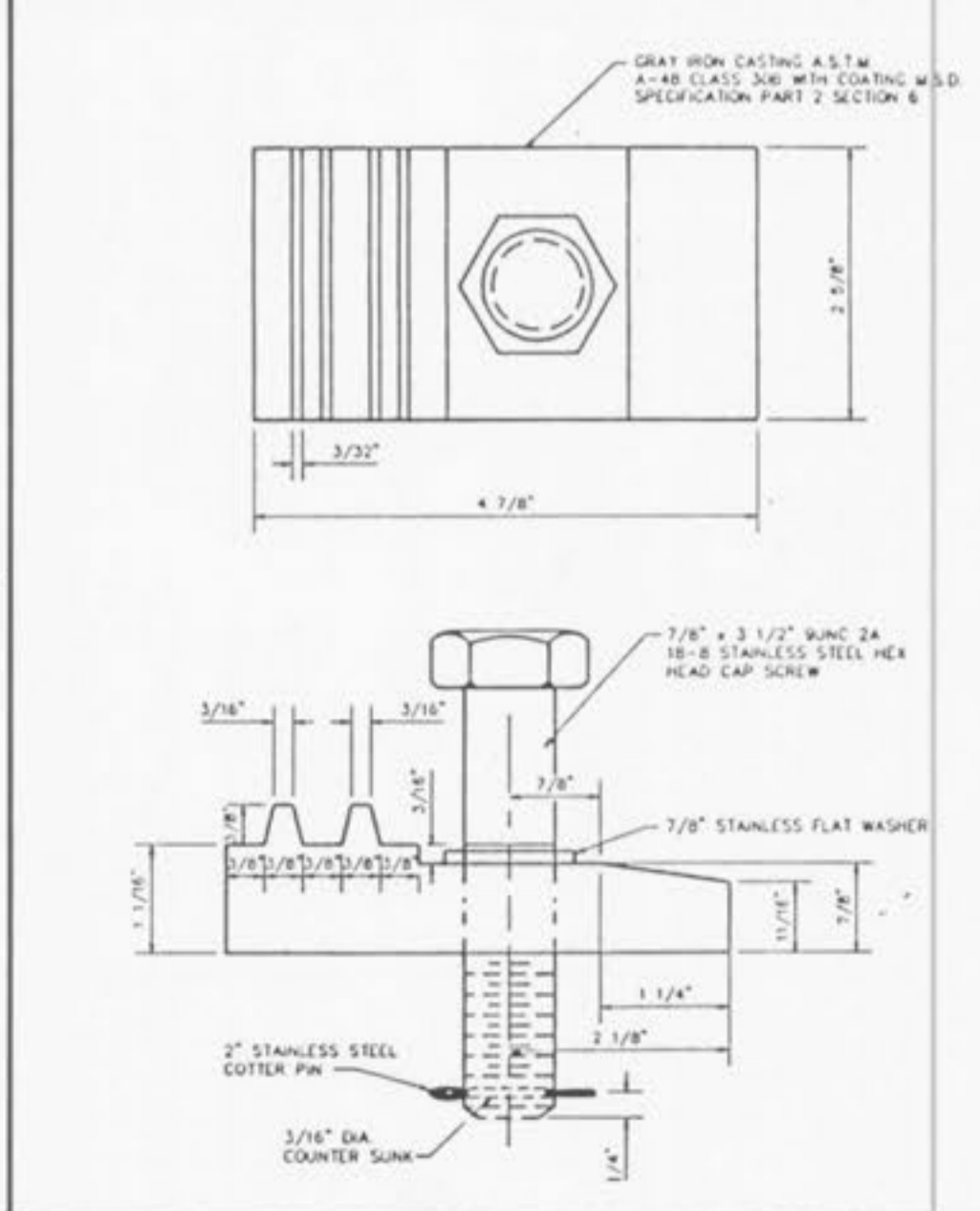
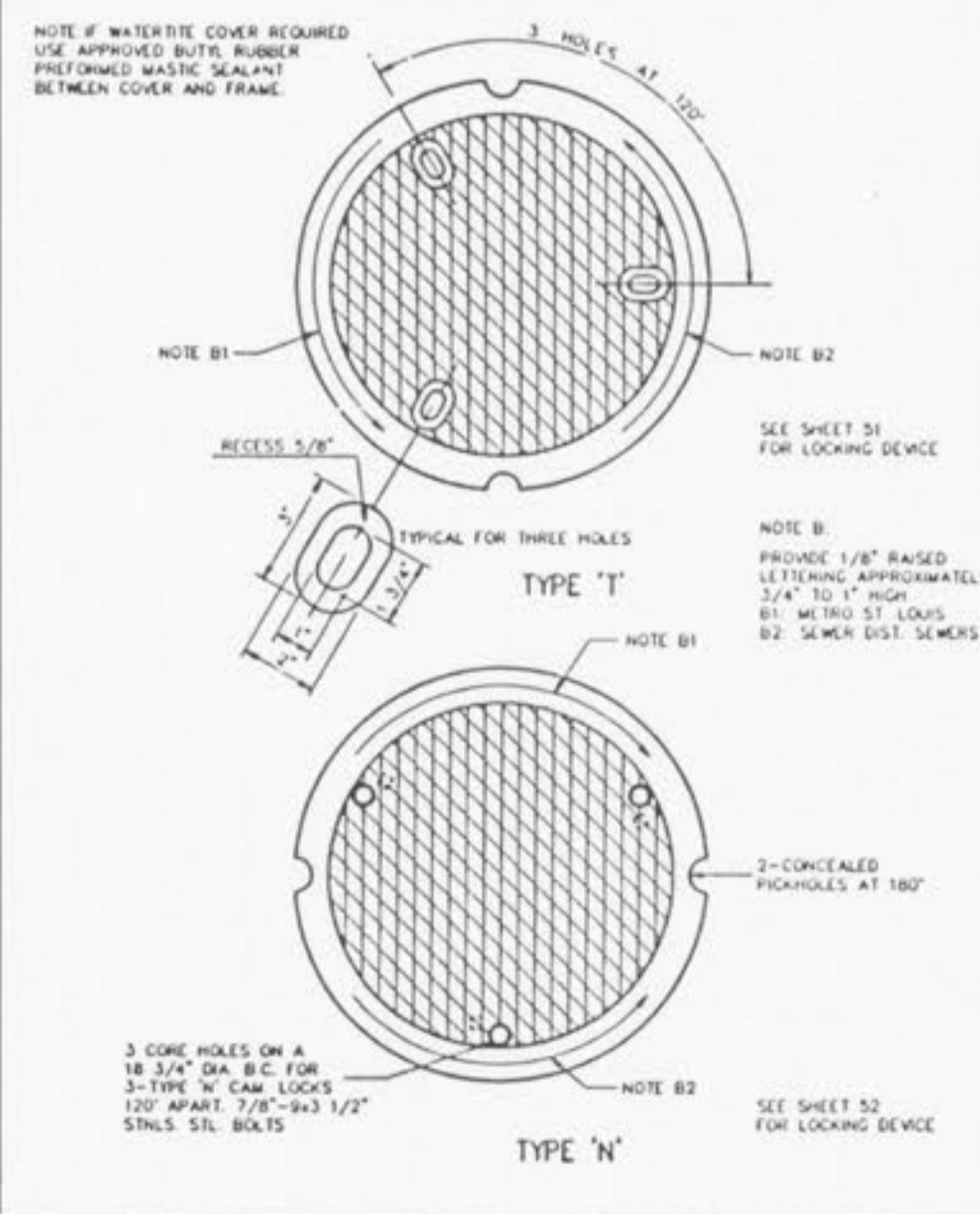
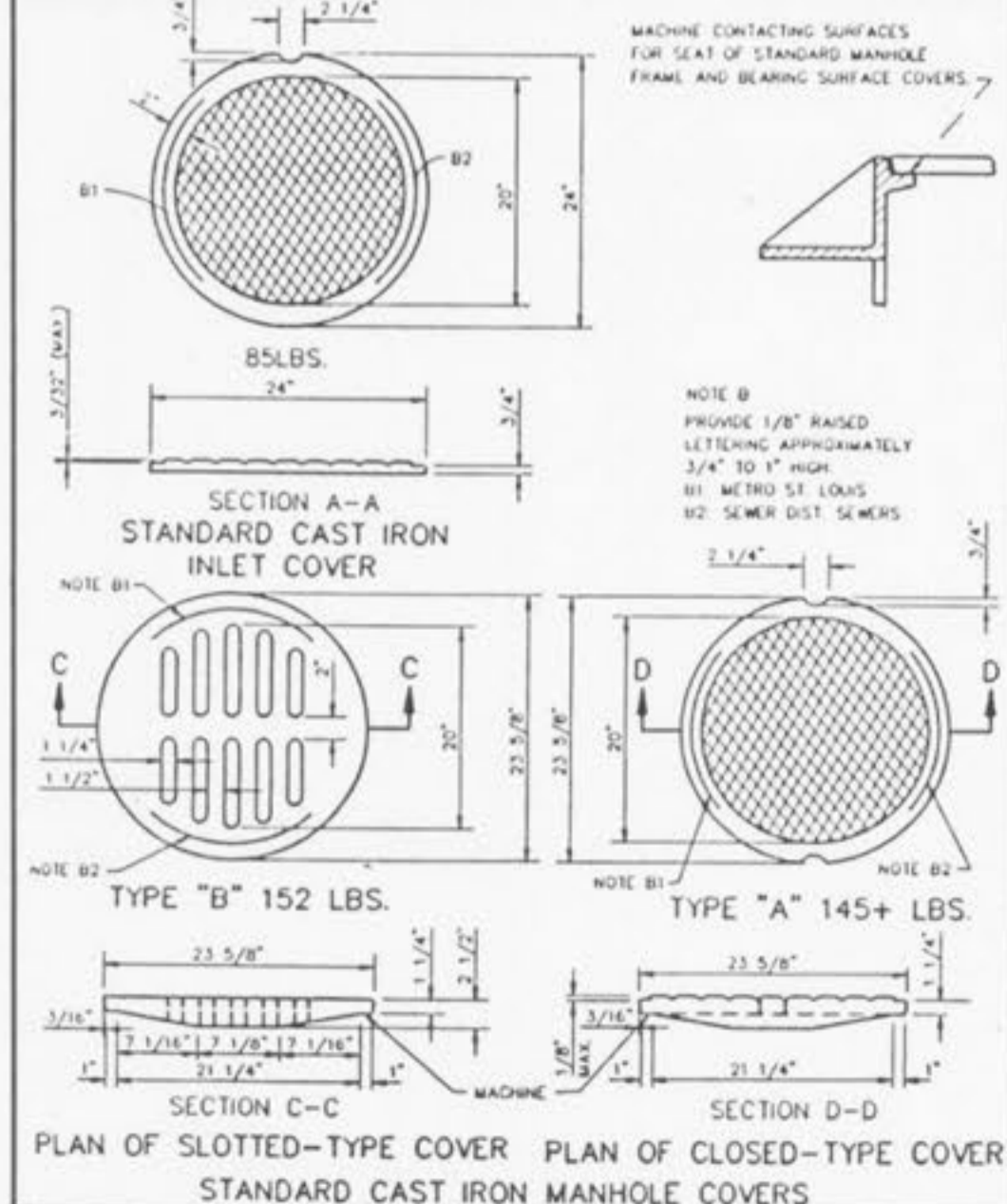

CAST IRON COVERS MANHOLES AND INLETS  
METROPOLITAN ST. LOUIS SEWER DISTRICT  
Standard Details of Sewer Construction  
Dr. R.C.W. Ch. J.C.K. 1992 SHEET 49

CAST IRON MANHOLE COVERS (LOCK TYPE)  
METROPOLITAN ST. LOUIS SEWER DISTRICT  
Standard Details of Sewer Construction  
Dr. W.S.H. Ch. J.C.K. 1992 SHEET 50

LOCKING DEVICE FOR TYPE 'T' LOCK TYPE MANHOLE COVER  
METROPOLITAN ST. LOUIS SEWER DISTRICT  
Standard Details of Sewer Construction  
Dr. R.C.W. Ch. J.C.K. 1992 SHEET 51

LOCKING DEVICE FOR TYPE 'N' LOCK TYPE MANHOLE COVER  
METROPOLITAN ST. LOUIS SEWER DISTRICT  
Standard Details of Sewer Construction  
Dr. J.L.G. Ch. J.C.K. 1992 SHEET 52

PS1-B MANHOLE STEP INTO JOINT  
METROPOLITAN ST. LOUIS SEWER DISTRICT  
Standard Details of Sewer Construction  
Dr. W.S.H. Ch. J.C.K. 1992 SHEET 53

MANHOLE STEP FOR PRECAST MANHOLE  
METROPOLITAN ST. LOUIS SEWER DISTRICT  
Standard Details of Sewer Construction  
Dr. D.A.B. Ch. J.C.K. 1992 SHEET 54