







NOTE: ALL STRIPING WITHIN MODOT RIGHT-OF-WAY MUST BE APPROVED BY THE MODOT TRAFFIC STUDIES ENGINEER BEFORE APPLICATION.

NOTES

- ALL PAVEMENT MARKINGS AND SIGNS SHALL CONFORM TO THE COLORS STANDARDS AND SPECIFICATIONS REFERENCED IN THE "MANUAL ON UNIFORM TRAFFIC CONTROL DEVICES" LATEST EDITION.
-  = EXISTING 4" SOLID YELLOW LINE WITH 4" DASHED YELLOW LINE (INSIDE) (6' OPEN SPACE BETWEEN SOLID AND DASHED LINES, DASHED LINES ARE 10' LONG WITH 30' SPACES)
 = 4" SOLID WHITE LINE
 = DOUBLE 4" SOLID YELLOW LINE
 = 6" SOLID WHITE LINE
 = 12" SOLID WHITE LINE
 = EXISTING 4" DASHED WHITE LINE
 = EXISTING 4" SOLID WHITE LINE

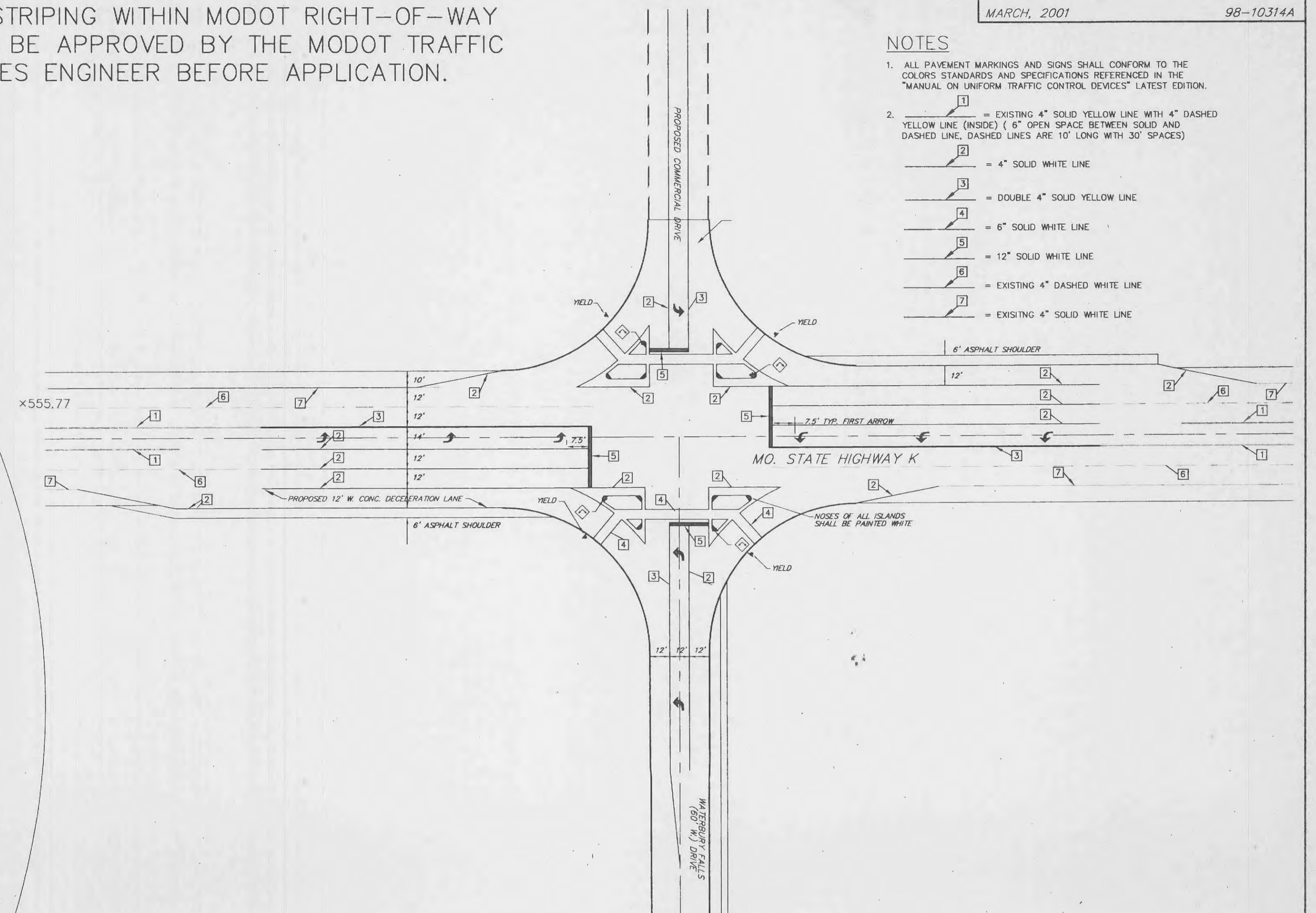
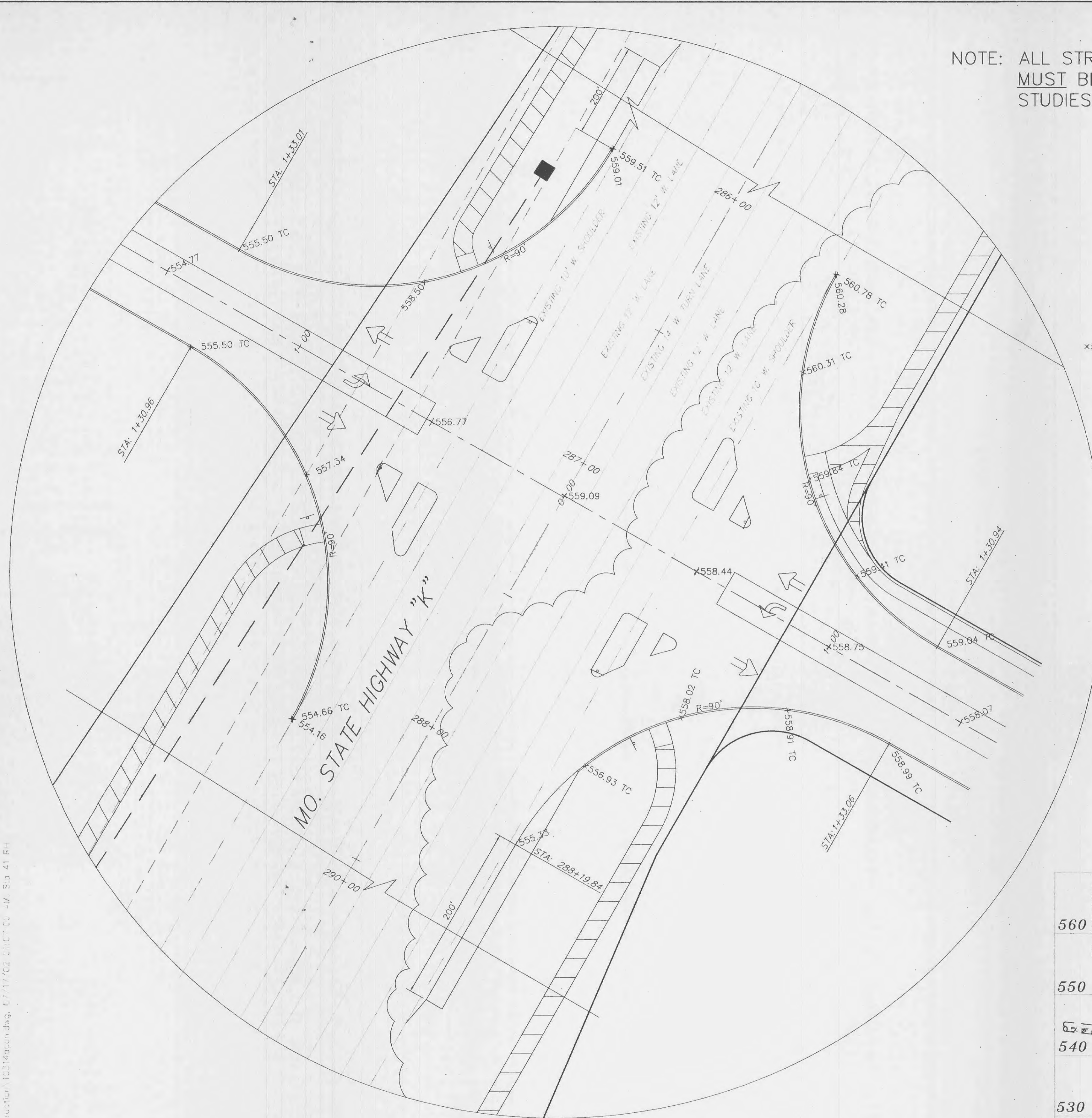

WATERBURY FALLS DRIVE/MO. STATE HIGHWAY "K"
 INTERSECTION STRIPING DETAIL
 NTS

WATERBURY FALLS DRIVE & MO. STATE HIGHWAY "K"
 SCALE: 1" = 20'

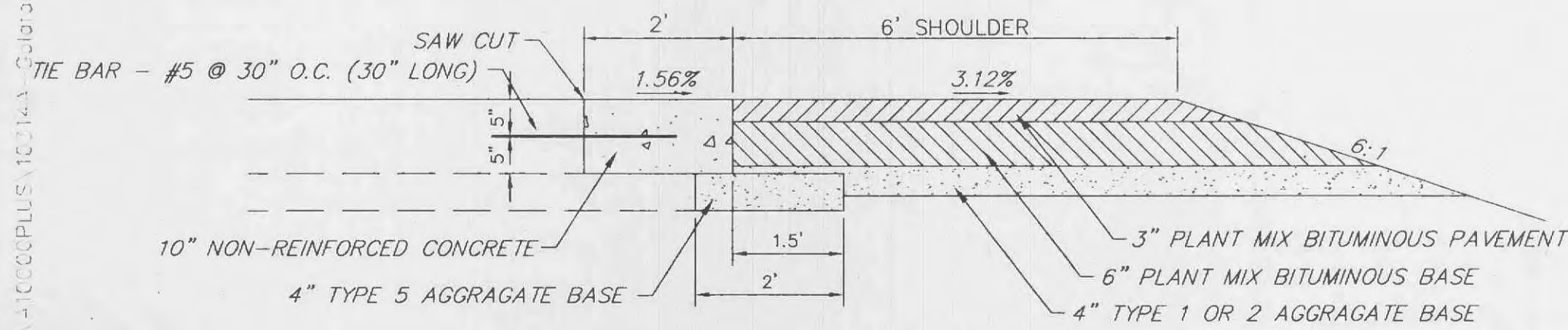

SHOULDER DETAIL
 NTS

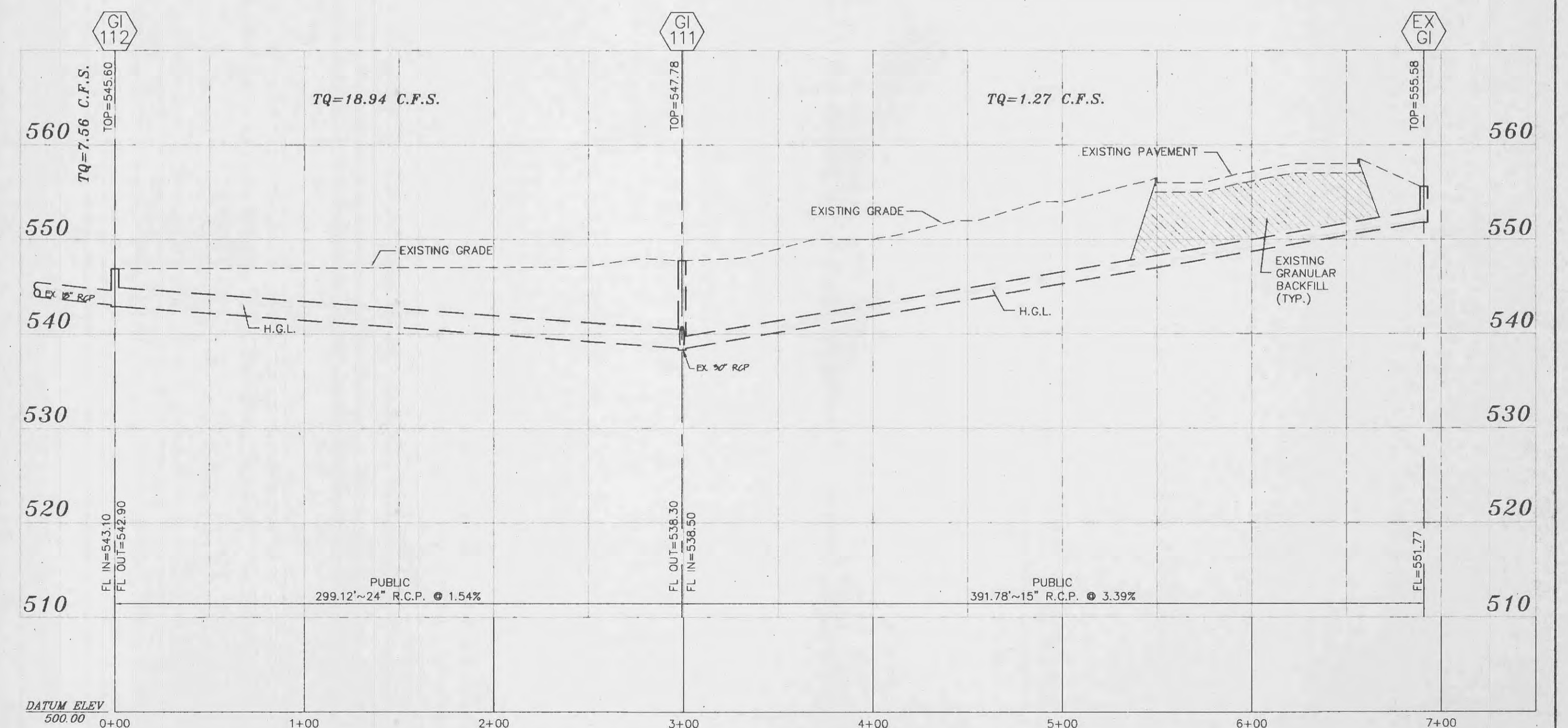

STORM SEWER PROFILE

SCALE: 1"=10' VERTICAL
 1"=50' HORIZONTAL

E:\DWG\PROJECTS\10314A\10314A.dwg, 07/17/02, 01:02:00 -M, S3, 41 RH