

GENERAL NOTES

- GN # 1 Driveway locations shall not interfere with the sidewalk handicap ramps, or curb inlet sumps
- GN # 2 Sidewalks, curb ramps, ramps and accessible parking spaces shall be constructed in accordance with the current approved "American with Disabilities Act Accessibility Guidelines" (ADAAG) along with the required grades, construction materials, specifications and signage. If any conflict occurs between the above information and the plans, the ADAAG guidelines shall take precedence and the contractor prior to any construction shall notify the Project Engineer.
- GN # 3 Truncated domes for curb ramps located in public right of way shall meet ADA requirements and shall be constructed using red pre cast truncated domes per pavement details.
- GN # 4 Any proposed pavilions or playground areas will need a separate permit from the Building Division.
- GN # 5 The Contractor is responsible to call Missouri One Call and The City of O'Fallon for the location of utilities. Contact the City of O'Fallon (636) 379-3814 for the location of City maintained cable for street lights and traffic signals, all other utilities call Missouri One Call 1-800-DIG-RITE. 1-800-344-7483
- GN # 6 All proposed utilities and/or utility relocations shall be located underground.
- GN # 7 All proposed fencing requires a separate permit through the Planning and Development Division.
- GN # 8 All construction operations and work zone traffic control within the right of way will follow MoDOT or M.U.T.C.D. standards whichever is more stringent.
- GN # 9 All free standing signs shall be located a minimum of ten (10) feet away from any right of way line and/or property line and a minimum of three (3) feet from the back of curbing or sidewalk. All signs shall abide by the regulations for visibility at corners, including corners from driveways and the street it intersects per Section 400.260 of the O'Fallon Zoning Code.
- GN #10 All subdivision identification or directional sign(s) must have the locations and sizes approved and permitted separately through the Planning and Development Division.
- GN #11 Materials such as trees, organic debris, rubble, foundations, and other deleterious material shall be removed from the site and disposed of in compliance with all applicable laws and regulations. If the material listed previously are reused, a letter from a soil Engineer must clearly amount, location, depth, etc. and be approved with the construction plans. Landfill tickets for such disposal shall be maintained on file by the developer. Burning on site shall be allowed only by permit from the local fire district. If a burn pit is proposed the location and mitigation shall be shown on the grading plan and documented by the soils engineer.
- GN #12 Twenty-four (24) hours prior to starting any of the work covered by the above plans and after approval thereof, the developer shall make arrangements with the Construction Inspection Office to provide for inspection of the work, sufficient in the opinion of the City Engineer, to assure compliance with the plans and specifications as approved.
- GN #13 The City Engineer or their duly authorized representative shall make all necessary inspections of City infrastructure, escrow items or infrastructure located on the approved plans.

Erosion Control Notes

- EN # 1 The Permittee shall assume complete responsibility for controlling all siltation and erosion of the project area. The Permittee shall use whatever means necessary to control erosion and siltation including, but not limited to, staked straw bales and/or siltation fabric fences (possible methods of control are detailed in the plan). Control shall commence with the clearing operations and be maintained throughout the project until acceptance of the work by City of O'Fallon and as needed by MoDOT. The Permittee's responsibilities include all design and implementation as required to prevent erosion and the depositing of silt. The City of O'Fallon and as required by MoDOT may at their option direct the Permittee in his methods as deemed fit to protect property and improvements. Any depositing of silt or mud on new or existing pavement shall be removed immediately. Any depositing of silt or mud in new or existing storm sewers and/or swales shall be removed after each rain and affected areas cleaned to the satisfaction of the City of O'Fallon and as required by MoDOT.
- EN # 2 All erosion control systems are to be inspected and corrected weekly, especially within 48 hours of any rain storm resulting in one-half inch of rain or more. Any silt or debris leaving the site and affecting public right of way or storm water drainage facilities shall be cleaned up within 24 hours after the end of the storm.
- EN # 3 Erosion control devices (silt fence, sediment basin, etc.) shall be in accordance with St. Charles County Soil and Water Conservation District Erosion and Sediment Control guidelines.
- EN # 4 This development is required to provide long term post construction BMP's such as; low impact design, source control and treatment controls that protects water quality and controls run off to maximum extent practical in compliance with Phase II Illicit Storm Water Discharge Guidelines. (Ord. 5082, section 405.0245)
- EN #5 Graded areas shall be seeded and mulched (strawed) within 14 days of stopping land disturbance activities. Unless it can be shown to the City Engineer that weather conditions are not favorable, vegetative growth is to be established within 6 weeks of stopping grading work on the project. The vegetative growth established shall be sufficient to prevent erosion and the standard shall be as required by EPA and DNR. (70% coverage per square foot) Ord. 5242, Section 405.070

Grading Notes

- GRN #1 Developer must supply City construction inspectors with soil reports prior to and during site grading. The soil report will be required to contain the following information on soil test curves (Proctor reports) for projects within the City:
  1. Maximum dry density
  2. Optimum moisture content
  3. Maximum and minimum allowable moisture content
  4. Curve must be plotted to show density from a minimum of 90% Compaction and above as determined by the "Modified AASHTO T-180 Compaction Test" (A.S.T.M.-D-1157) or from a minimum of 95% as determined by the "Standard Proctor Test ASHTO T-99, Method C" (A.S.T.M.-D-698). Proctor type must be designated on document.
  5. Curve must have at least 5 density points with moisture content and sample locations listed on document
  6. Specific gravity
  7. Natural moisture content
  8. Liquid limit
  9. Plastic limit
 Be advised that if this information is not provided to the City's Construction Inspector the City will not allow grading or construction activities to proceed on any applicable site.
- GRN #2 All fill placed in areas other than proposed storm sewers, sanitary sewers, proposed roads, and paved areas shall be compacted from the bottom of the fill up in 8" lifts and compacted to 90% maximum density as determined by Modified AASHTO T-180 compaction test or 95% of maximum density as determined by the Standard Proctor Test AASHTO T-99. Ensure the moisture content of the soil in fill areas corresponds to the compactive effort as defined by the Standard or Modified Proctor Test. Optimum moisture content shall be determined using the same test that was used for compaction. Soil compaction curves shall be submitted to the City of O'Fallon prior to the placement of fill.
- GRN # 3 The surface of the fill shall be finished so it will not impound water. If at the end of a days work it would appear that there may be rain prior to the next working day, the surface shall be finished smooth. If the surface has been finished smooth for any reason, it shall be scarified before proceeding with the placement of succeeding lifts. Fill shall not be placed on frozen ground, nor shall filling operations continue when the temperature is such as to permit the layer under placement to freeze.
- GRN # 4 All sediment and detention basins are to be constructed during the initial phase of the grading operation or in accordance with the approved SWPPP.
- GRN # 5 When grading operations are complete or suspended for more than 14 days, permanent grass must be established at sufficient density to provide erosion control on site. Between permanent grass seeding periods, temporary cover shall be provided according to St. Charles Soil and Water Conservation District - Model Sediment and Erosion Control Regulations. All finished grades (areas not to be disturbed by improvements) in excess of 20% slopes (5:1) shall be mulched and tacked at a rate of 100 pounds per 1000 square feet when seeded.
- GRN # 6 No slopes shall exceed 3 (horizontal): 1 (vertical) unless otherwise approved by the soils report and specifically located on the plans and approved by the City Engineer.
- GRN # 7 All low places whether on site or off shall be graded to provide drainage with temporary ditches.
- GRN # 8 All existing wells on site shall be capped per DNR standards.

Grading Notes Continued

- GRN #10 All trench back fills under paved areas shall be granular back fill, and compacted mechanically. All other trench back fills may be earth material (free of large clods, or stones) and compacted using either mechanical or water jetting. Granular material and earth material associated with new construction outside of pavements may be jetted, taking care to avoid damage to newly laid sewers. The jetting shall be performed with a probe route on not greater than 7.5 foot centers with the jetting probe centered over and parallel with the direction of the pipe. Trench widths greater than 10 feet will require multiple probes every 7.5 foot centers.
  - a) Depth, Trench back fills less than 8 feet deep shall be probed to a depth extending half the depth of the trench back fill, but not less than 3 feet. Trench back fill greater than 8 feet in depth shall be probed to half the depth of the trench back fill but not greater than 8 feet.
  - b) Equipment, The jetting probe shall be a metal pipe with an interior diameter of 1.5 to 2 inches.
  - c) Method, Jetting shall be performed from the lowest surface topographic point and proceed toward the highest point, and from the bottom of the trench back fill toward the surface. The flooding of each jetting probe shall be started slowly allowing slow saturation of the soil. Water is not allowed to flow away from the trench without first saturating the trench.
  - d) Surface Bridging, The contractor shall identify the locations of the surface bridging (the tendency for the upper surface to crust and arch over the trench rather than collapse and consolidate during the jetting process). The contractor shall break down the bridged areas using an appropriate method such as wheels or bucket of a backhoe. When surface crust is collapsed, the void shall be back filled with the same material used as trench back fill and jetted. Compaction of the materials within the sunken/jetted area shall be compacted such that no further surface subsidence occurs.
- GRN #11 Site grading.
  - a. Within City right-of-way. Material is to be placed in eight (8) inch to twelve (12) inch loose lifts and compacted per the approved compaction requirements. One (1) compaction test will be performed every two hundred fifty (250) feet along the centerline for each lift.
  - b. Outside of City right-of-way. Material is to be placed in eight (8) inch to twelve (12) inch loose lifts and compacted per the approved compaction requirements. One (1) compaction test will be performed at two (2) foot vertical intervals and approximately every one thousand (1,000) cubic yards.

Flood plain Information

FP #1 A flood plan development application from the City is required for any work within the flood plain limits.

Retaining Walls: Terraced and Vertical

- RW #1 A permit is required for all retaining walls that are 48 inches or taller in height, measured from the top of the footing to the top of the wall or for walls that support a surcharge load or that alters the channelized drainage of any lot or drainage area.
- RW #2 Retaining walls will not be allowed in public right-of-way without written approval from the City Engineer.
- RW #3 Any retaining wall more than thirty (30) inches tall which supports a walking surface that is within two (2) feet of the wall will require a guard on the retaining wall.
- RW #4 Retaining walls that alter the channeled drainage of any lot or drainage area shall not be constructed without prior approval and permitting from the City of O'Fallon Engineering Department regardless of the height of the wall.
- RW #5 See section 405.275 of the City code for additional design requirements.

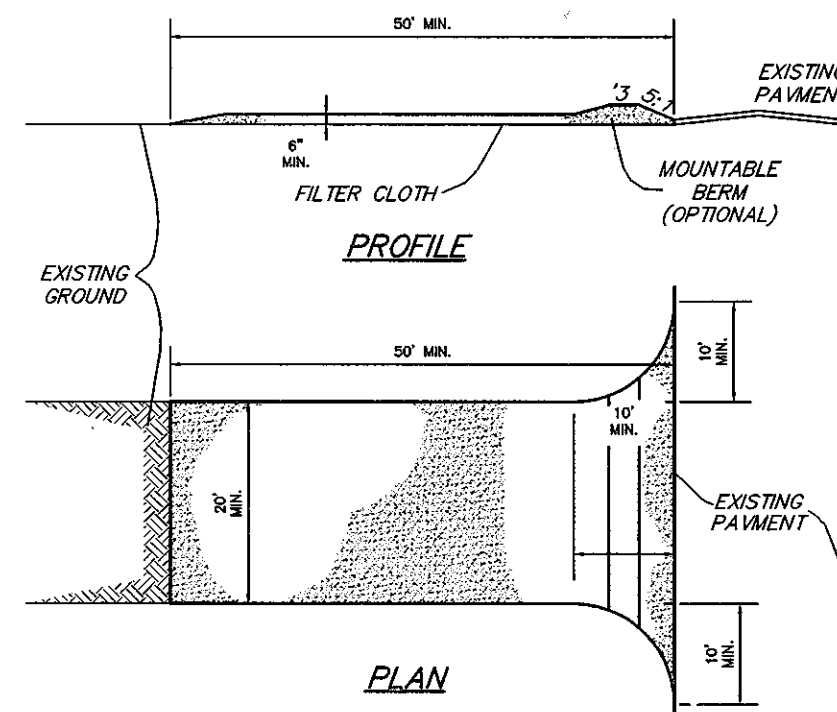

CONSTRUCTION SPECIFICATIONS

1. Stone Size - Use 2" stone, or reclaimed or recycled concrete equivalent.
2. Length - As required, but not less than 50 feet (except on a single residence lot where a 30 foot minimum length would apply).
3. Thickness - Not less than six (6) inches.
4. Width - Twenty (20) foot minimum, but not less than the full width at points where ingress or egress occurs.
5. Filter Cloth - Will be placed over the entire area prior to placing of stone. Filter will not be required on a single family residence lot.
6. Surface Water - All surface water flowing or diverted toward construction entrances shall be piped across the entrance. If piping is impractical, a mountable berm with 5:1 slopes will be permitted.
7. Maintenance - The entrance shall be maintained in a condition which will prevent tracking or flowing of sediment onto public rights-of-way. This may require periodic top dressing with additional stone as conditions demand and repair and/or cleanup of any measures used to trap sediment. All sediment spilled, dropped, washed or tracked onto public rights-of-way must be removed immediately.
8. Washing - Wheels shall be cleaned to remove sediment prior to entrance onto public rights-of-way. When washing is required, it shall be done on an area stabilized with stone and which drains into an approved sediment trapping device.
9. Periodic inspection and needed maintenance shall be provided after each rain.

STABILIZED CONSTRUCTION ENTRANCE/WASHDOWN AREA  
NOT TO SCALE



CUSTOM SIGN

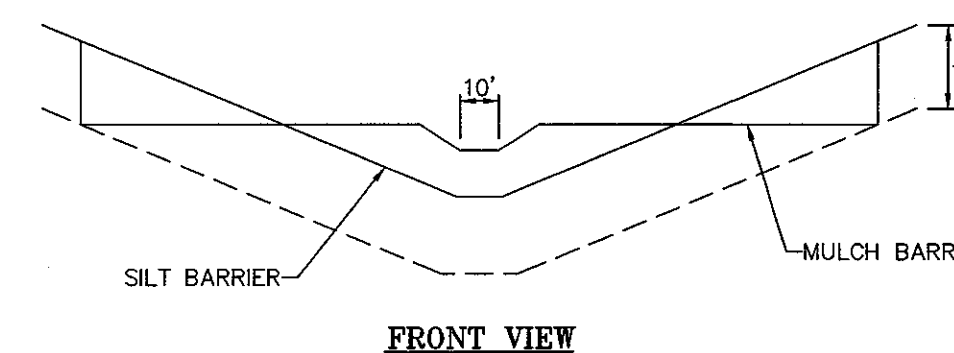

FRONT VIEW

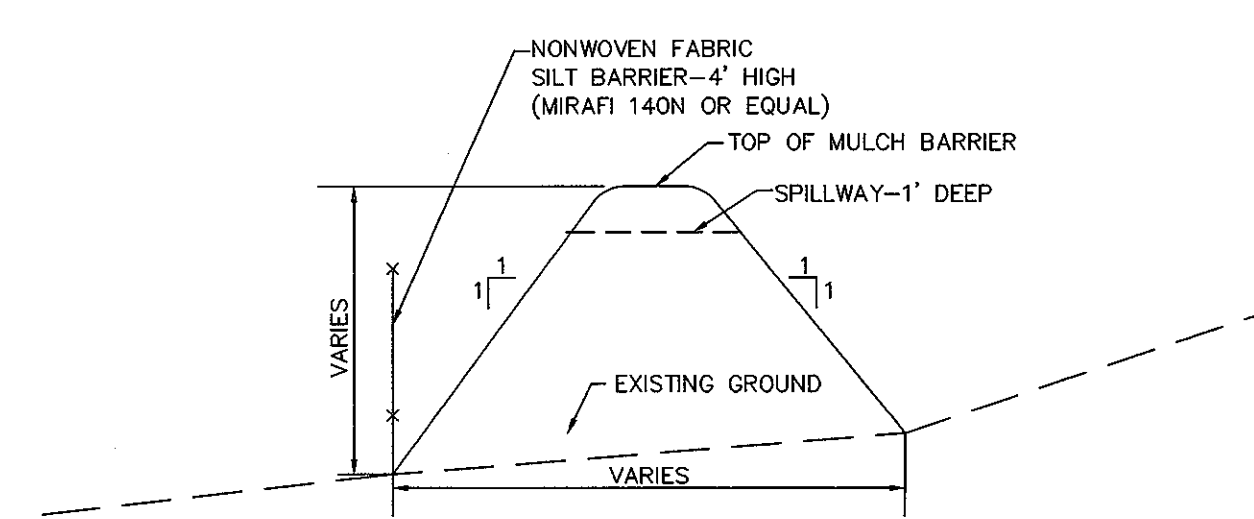

SEDIMENT TRAP MULCH BERM  
NOT TO SCALE

NOTE: CONTRACTOR TO USE MULCH FROM ONSITE CLEARING OPERATIONS FOR BERM.

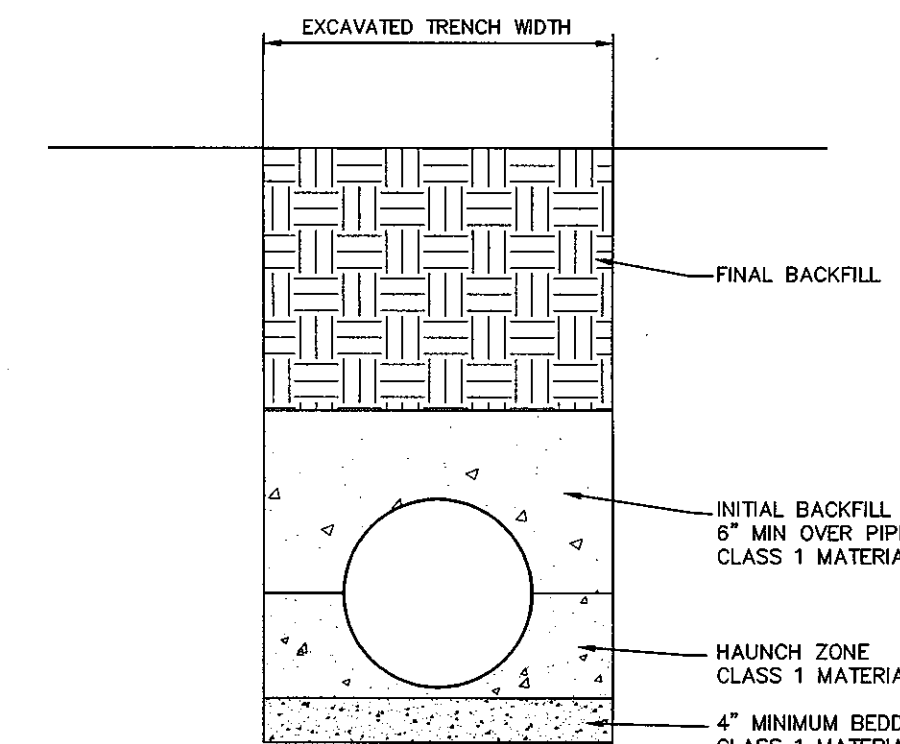

1. The use of High Density Polyethylene Corrugated pipe A.D.S. N12 or Equal will be permitted as an acceptable alternative to reinforced concrete pipe. Pipe shall meet A.S.T.M. D-2321 and AASHTO M-294-921. Concrete lined end sections and inlet structures shall be required. Pipe must have smooth interior wall and is not to be used inside the Public Right-of-Way. All concrete pipe or HDPE pipe shall be installed with o-ring rubber type gaskets per M.S.D. Standard Construction Specifications or Manufacturer.
2. In typical conditions the minimum trench width is determined by the size of the pipe and the ability to get compaction equipment between the pipe and the trench walls. The minimum trench width should not be less than the outside diameter plus 16 inches or the pipe outside diameter times 1.25 plus 12 inches; whichever is greater. High speed trenchers may enable satisfactory installation of pipe in narrower trenches. Poor in situ soil conditions such as peat, muck, running sands, or expansive clays will require substantially wider backfill as well as deeper foundation and bedding. Trench width and foundation depth should be based on a thorough site investigation.
3. Backfill in the area up to the springline should be carefully placed and compacted to achieve a minimum E value of 1,000 psi as detailed in ASTM D2321. A minimum of 12" of backfill should be placed and compacted above the crown of the pipe. It is typical for trenches to be backfilled entirely with Type I or Type II materials when under pavement.
4. Flexible pipe should never be installed in a concrete cradle, as done for rigid pipe in a Class A installation. This type of installation could create concentrated forces at the ends of the cradle when the pipe has deformed.

H.D.P.E. PIPE DETAIL

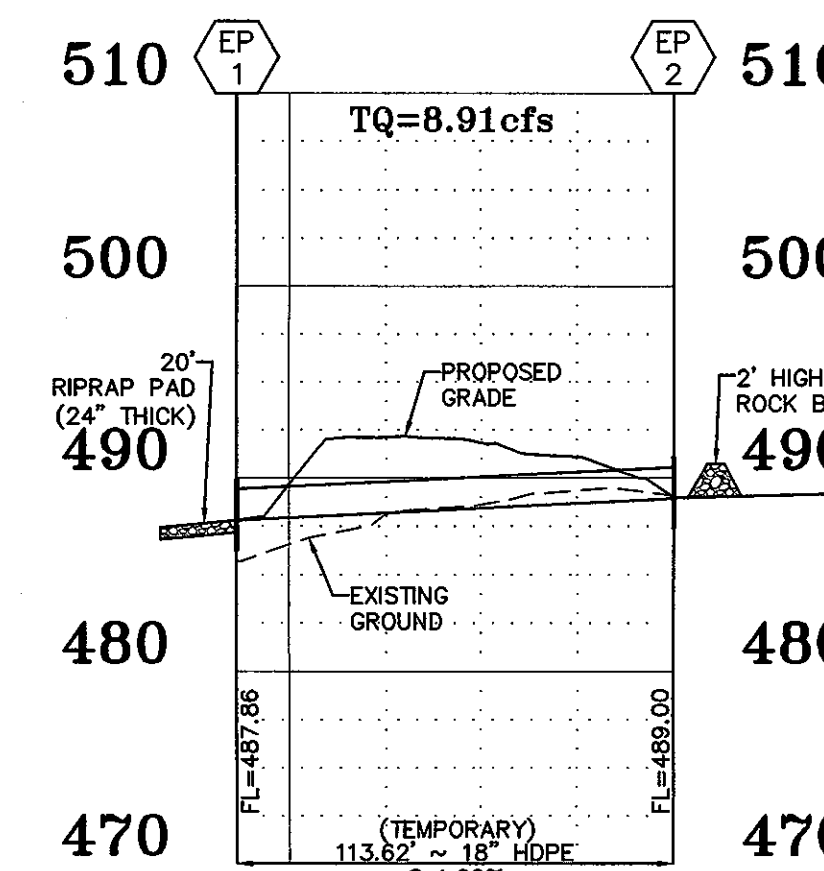

STORM SEWER PROFILE

SCALES:  
HORIZ. 1"=50'  
VERT. 1"=10'

**PROJECT TITLE:**  
**KEYSTONE RIDGE**

**ENGINEERING PLANNING SURVEYING**  
221 Point View Blvd.  
St. Charles, MO 63801  
636-928-5562  
FAX 636-928-1718

**STATE OF MISSOURI REGISTERED PROFESSIONAL ENGINEER**  
CLIFFORD L. HEITMANN  
NUMBER E-29817

CLIFFORD L. HEITMANN  
CIVIL ENGINEER  
E29817

Copyright 2017  
Sax Engineering Company, Inc.  
Authority No. 000653  
All Rights Reserved

REVISIONS	
04/05/17	CITY COMMENTS
05/16/17	CITY COMMENTS
05/31/17	CITY COMMENTS

Developer / Owner:  
**KEYSTONE RIDGE LAND, LLC**  
10328 LAKE BLUFF DRIVE  
ST. LOUIS, MO 63123  
314-892-3030 EXT. 121

**GRADING NOTES AND DETAILS**

P+Z No. #32-16  
City No. #  
Page No. 2 of 5