

AREA INLET MANHOLE (12" THRU 24")	METROPOLITAN ST. LOUIS SEWER DISTRICT Standard Details of Sewer Construction
Dr. RGW/SAM Ch. J.C.K.	2000 SHEET 30

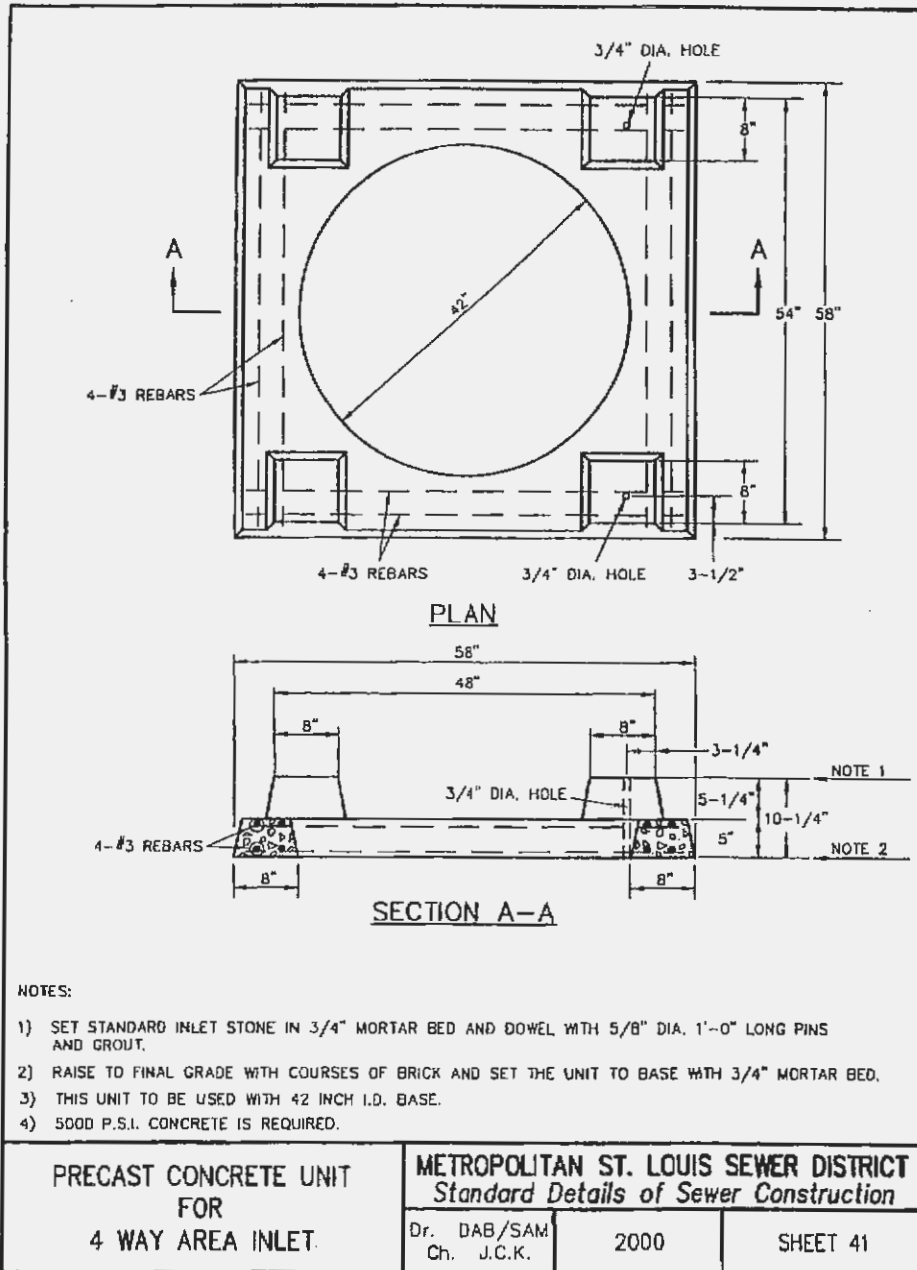

PRECAST CONCRETE UNIT FOR 4 WAY AREA INLET	METROPOLITAN ST. LOUIS SEWER DISTRICT Standard Details of Sewer Construction
Dr. DAB/SAM Ch. J.C.K.	2000 SHEET 41

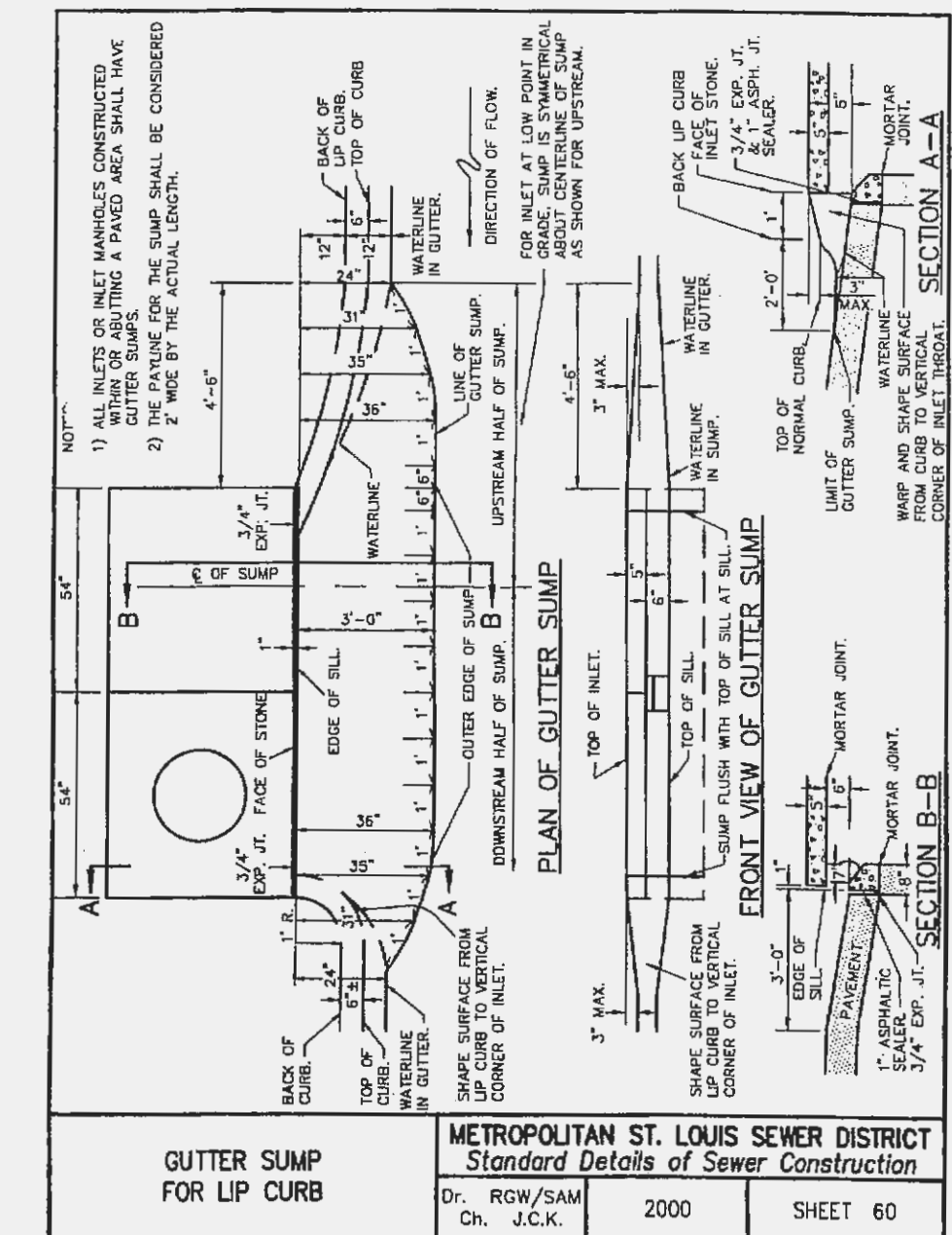

GUTTER SUMP FOR LIP CURB	METROPOLITAN ST. LOUIS SEWER DISTRICT Standard Details of Sewer Construction
Dr. RGW/SAM Ch. J.C.K.	2000 SHEET 60

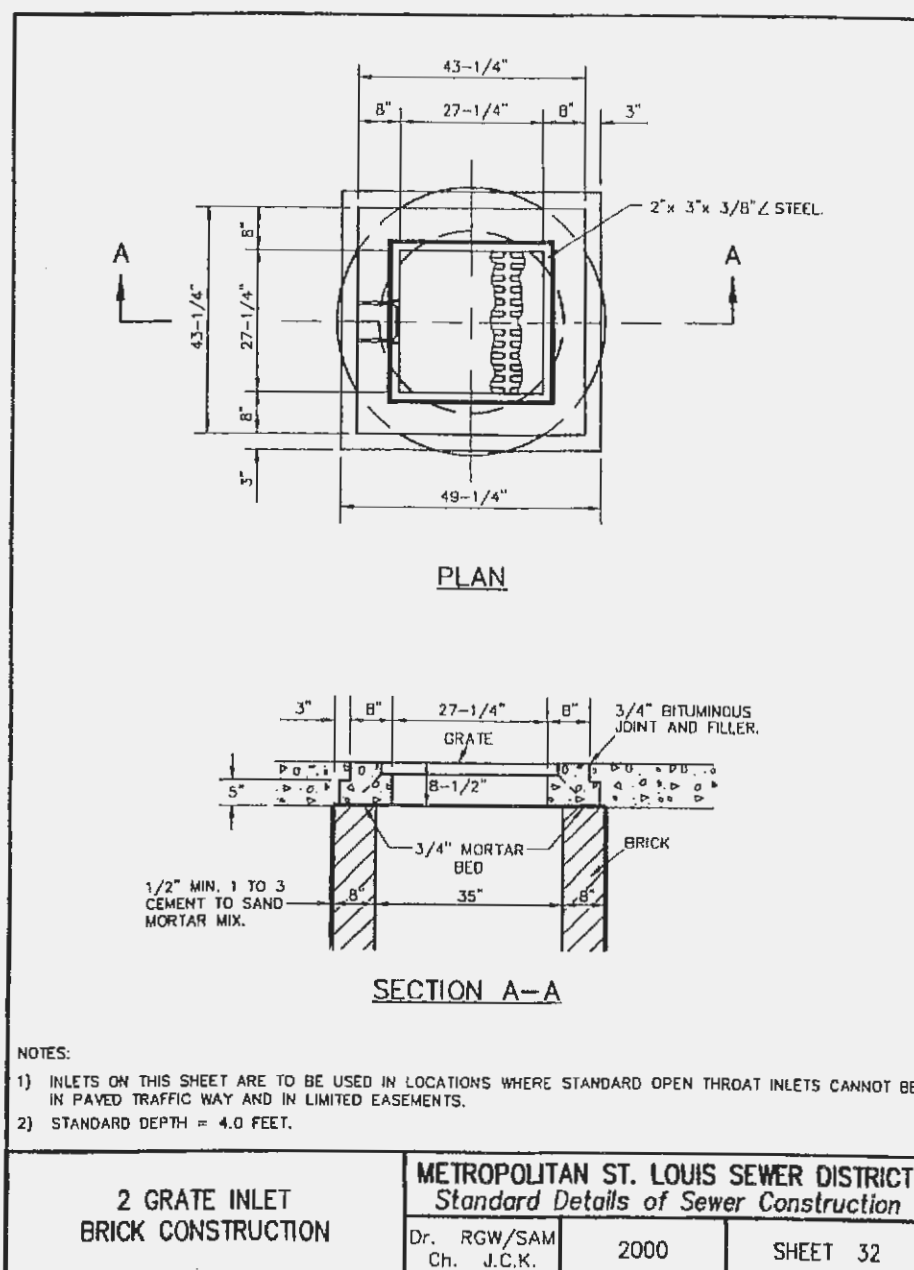

2 GRATE INLET BRICK CONSTRUCTION	METROPOLITAN ST. LOUIS SEWER DISTRICT Standard Details of Sewer Construction
Dr. RGW/SAM Ch. J.C.K.	2000 SHEET 32

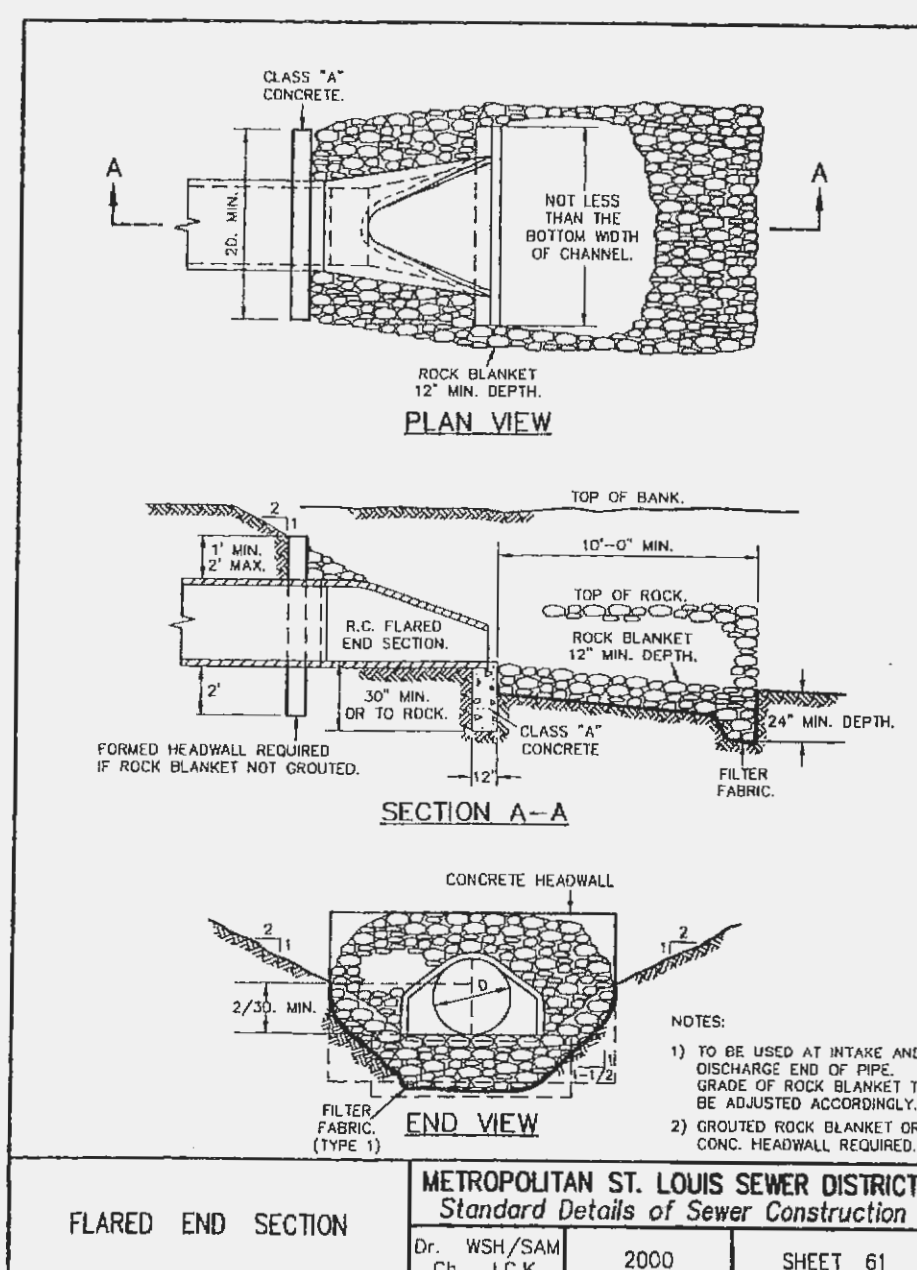

FLARED END SECTION	METROPOLITAN ST. LOUIS SEWER DISTRICT Standard Details of Sewer Construction
Dr. WSH/SAM Ch. J.C.K.	2000 SHEET 61

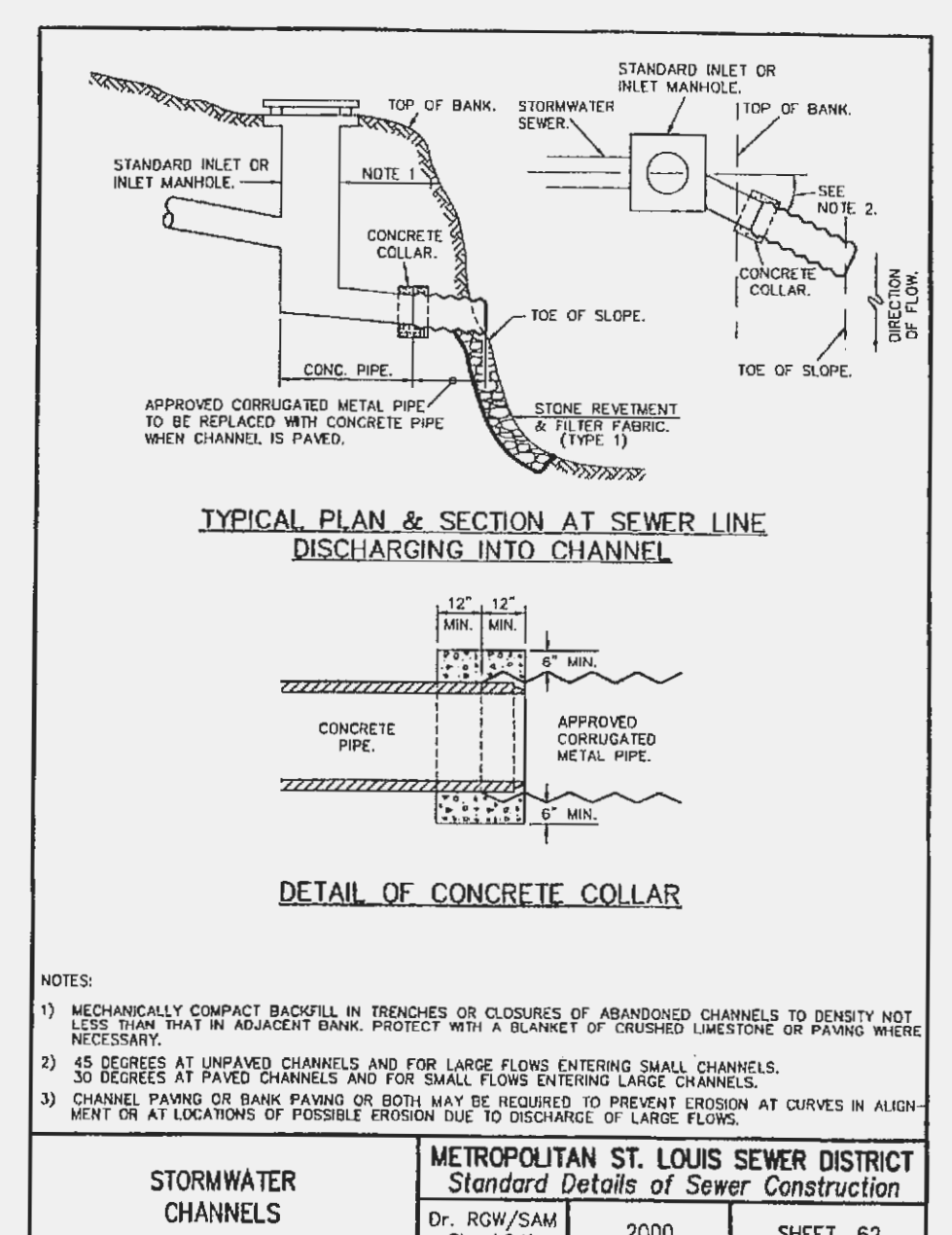

STORMWATER CHANNELS	METROPOLITAN ST. LOUIS SEWER DISTRICT Standard Details of Sewer Construction
Dr. RGW/SAM Ch. J.C.K.	2000 SHEET 62

PRECAST CONCRETE STORMWATER STRUCTURES
MINIMUM DISTANCE FLOWLINE TO TOP OF STONE OR GRATE

PIPE I.D. NOMINAL INCHES	AREA INLET CIRCULAR BASE DIA.		(2) GRATE INLET CIRCULAR BASE DIA. SQUARE CIRCULAR BASE DIA. RECTANGLE (MAX.)		SINGLE STREET INLET CIRCULAR BASE DIA. RECTANGLE (MAX.)	
	42"	48" 60"	42"	48" 60"	42"	48" 60"
12"	48"	60"	36"	48"	36"	48"
15"	48"	60"	41"	51"	41"	51"
18"	52"	64"	44"	55"	44"	55"
21"	55"	67"	47"	58"	47"	58"
24"	58"	70"	51"	61"	51"	61"
27"	78"	84"	71"	NA	71"	NA
30"	82"	88"	74"	NA	74"	NA
33"	85"	91"	77"	NA	77"	NA

(SEE SHEET 35 FOR DETAIL) (SEE SHEET 36 FOR DETAIL) (SEE SHEET 37 FOR DETAIL)

PRECAST CONCRETE STORMWATER STRUCTURES	METROPOLITAN ST. LOUIS SEWER DISTRICT Standard Details of Sewer Construction
Dr. J.L.G. Ch. J.C.K.	2000 SHEET 34

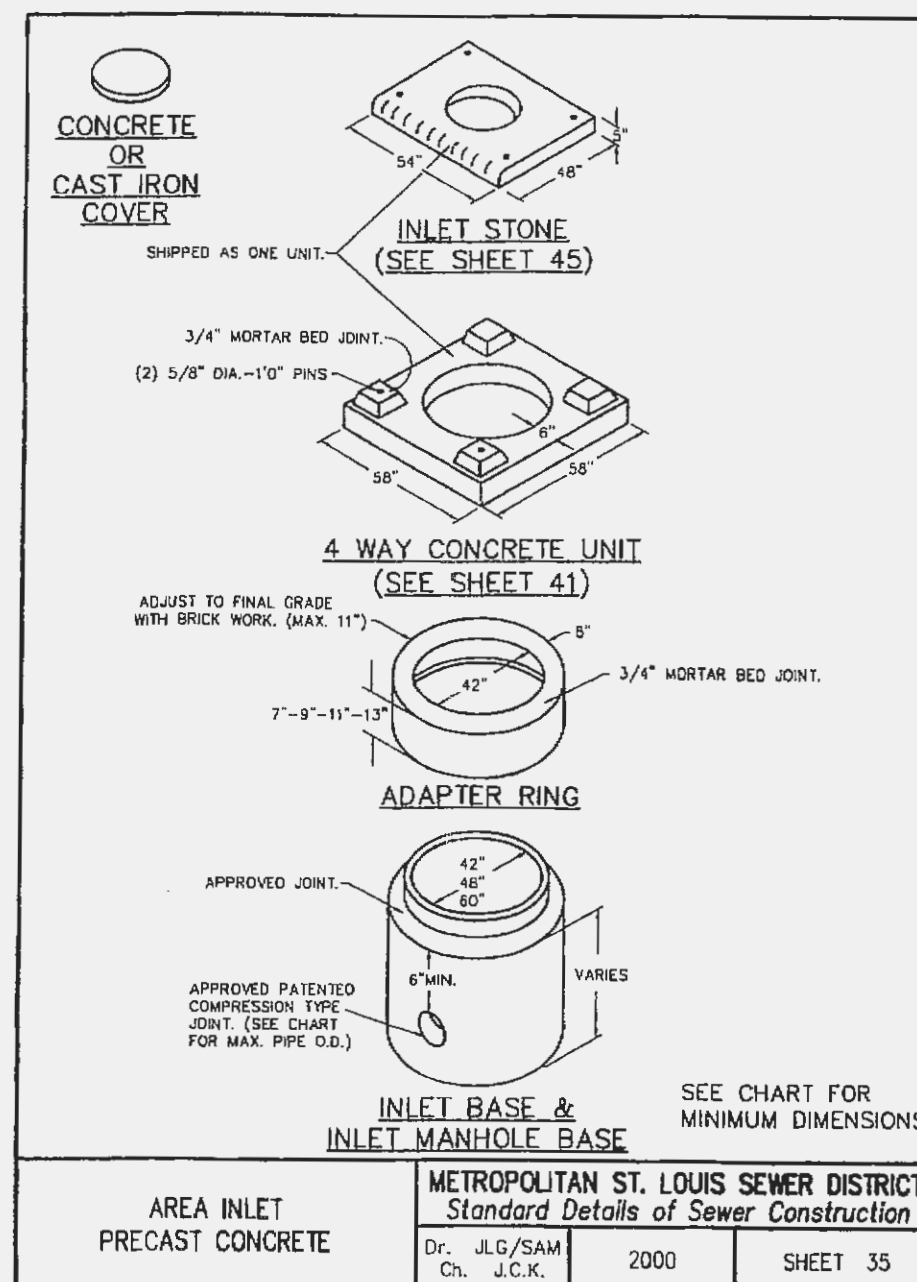

AREA INLET PRECAST CONCRETE	METROPOLITAN ST. LOUIS SEWER DISTRICT Standard Details of Sewer Construction
Dr. J.L.G./SAM Ch. J.C.K.	2000 SHEET 35

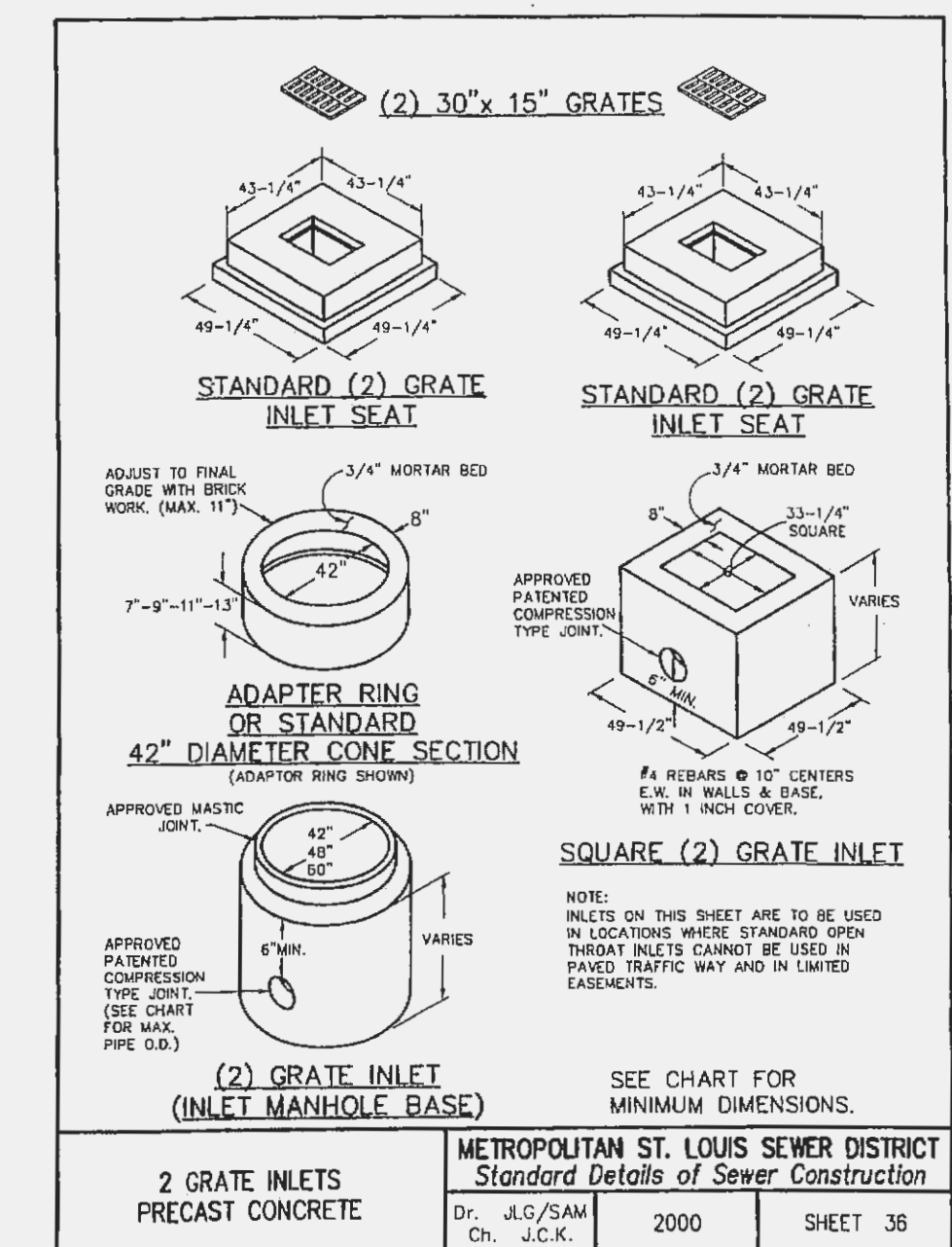

2 GRATE INLETS PRECAST CONCRETE	METROPOLITAN ST. LOUIS SEWER DISTRICT Standard Details of Sewer Construction
Dr. J.L.G./SAM Ch. J.C.K.	2000 SHEET 36

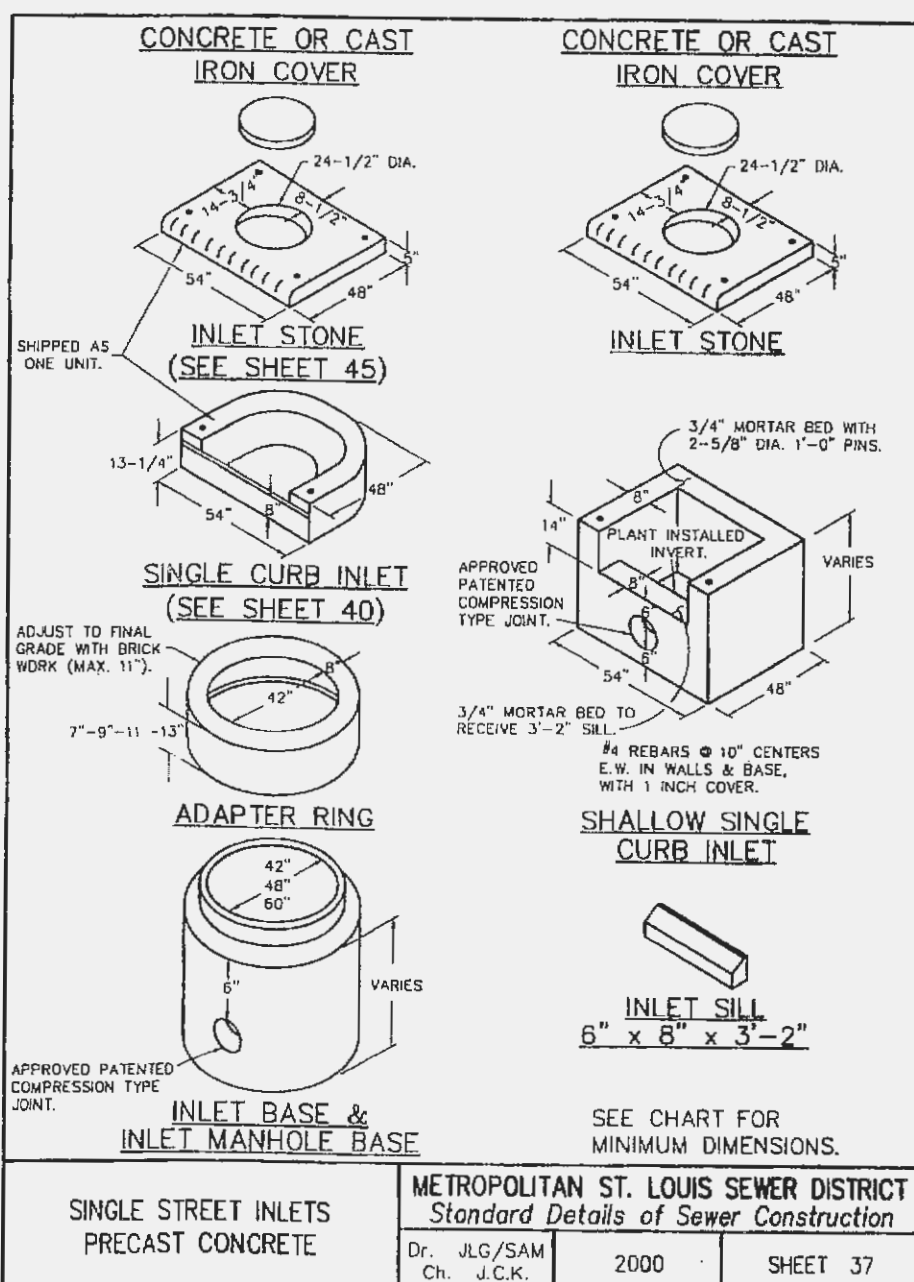

SINGLE STREET INLETS PRECAST CONCRETE	METROPOLITAN ST. LOUIS SEWER DISTRICT Standard Details of Sewer Construction
Dr. J.L.G./SAM Ch. J.C.K.	2000 SHEET 37

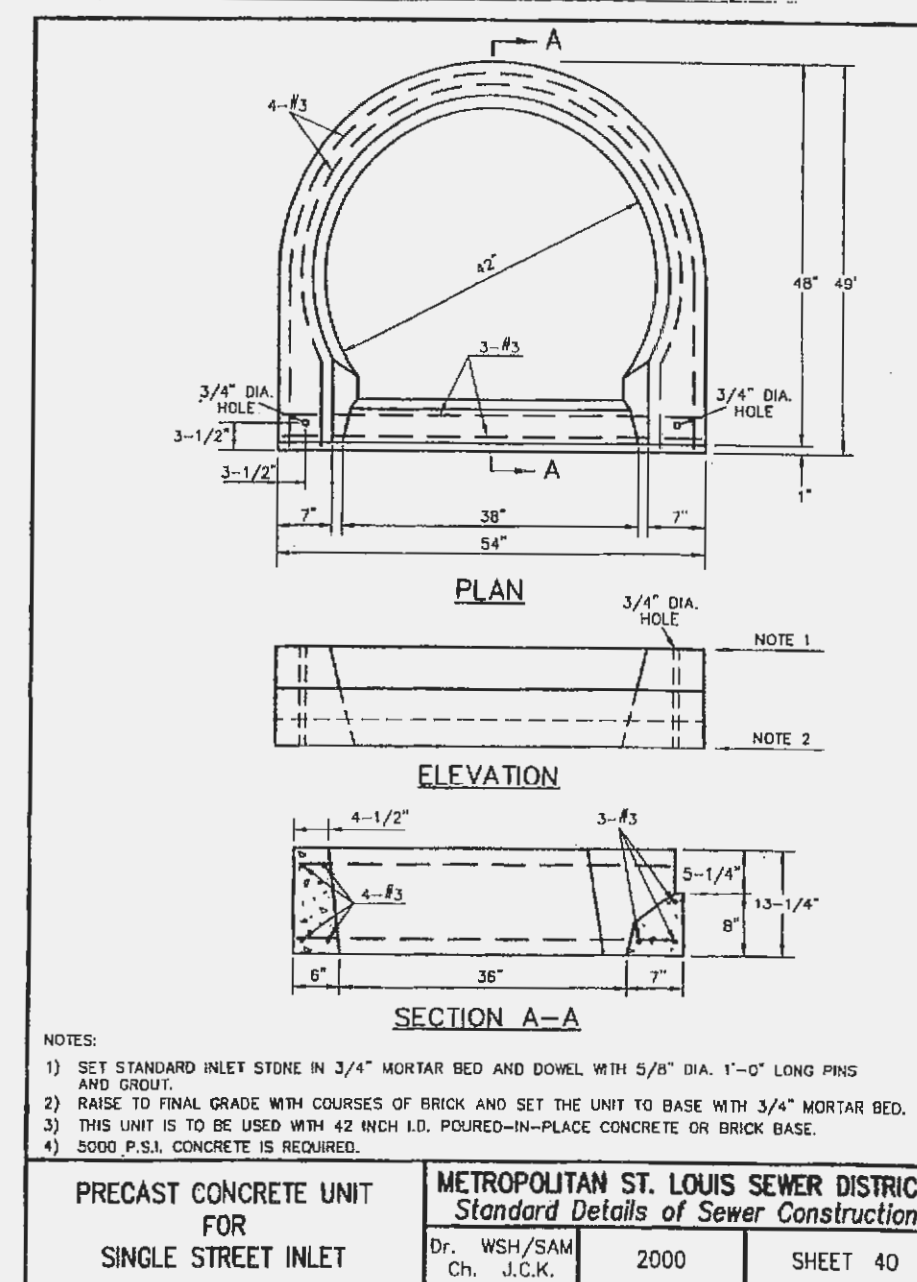

PRECAST CONCRETE UNIT FOR SINGLE STREET INLET	METROPOLITAN ST. LOUIS SEWER DISTRICT Standard Details of Sewer Construction
Dr. WSH/SAM Ch. J.C.K.	2000 SHEET 40

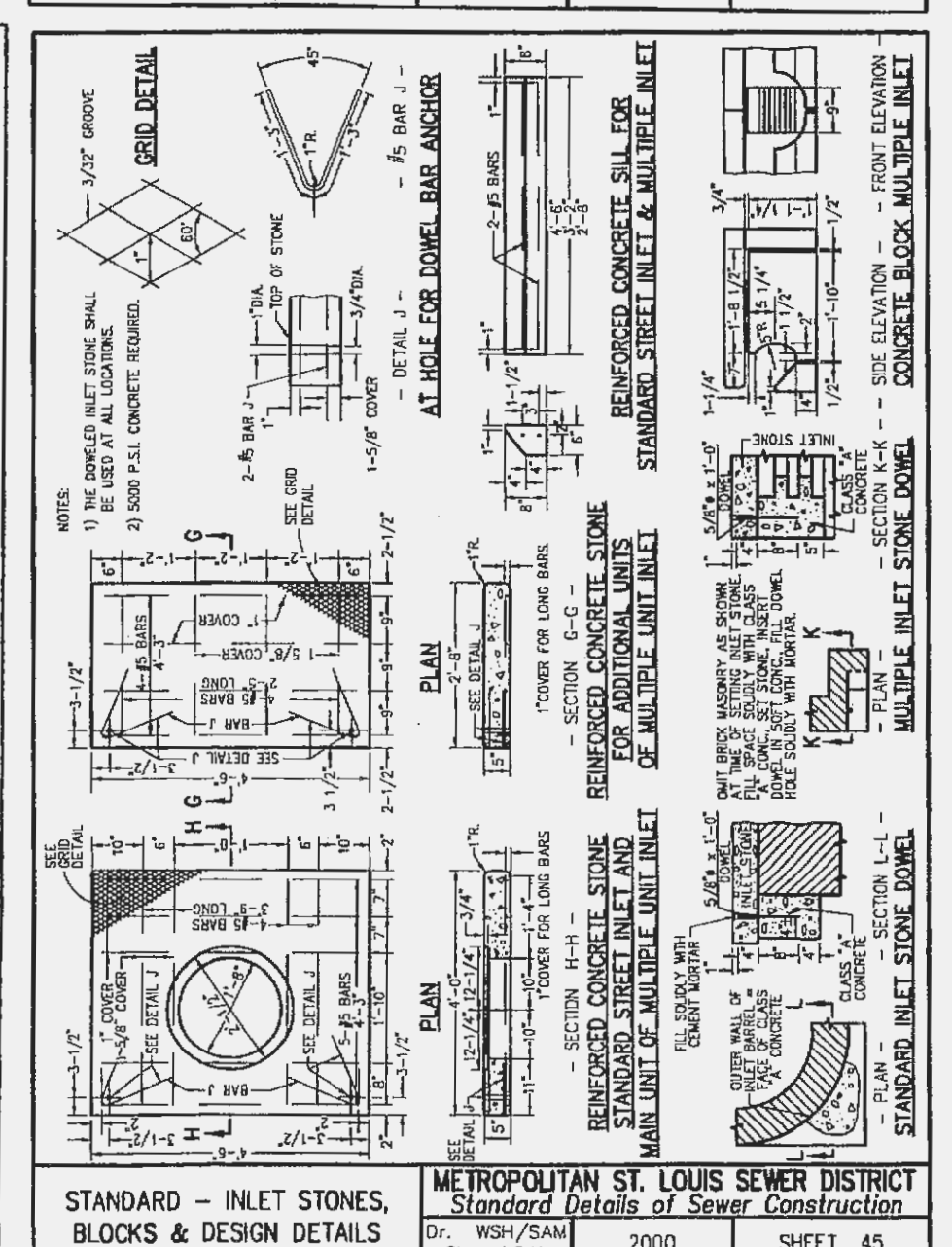

STANDARD - INLET STONES, BLOCKS & DESIGN DETAILS	METROPOLITAN ST. LOUIS SEWER DISTRICT Standard Details of Sewer Construction
Dr. WSH/SAM Ch. J.C.K.	2000 SHEET 45

NOTE:
NO PRECAST MANHOLES LIDS ARE ALLOWED

10/20/04
REVISED PER CITY COMMENTS

LAUREL SPRINGS
STORM DETAILS
IMPROVEMENT PLAN

ST. CHARLES ENGINEERING & SURVEYING, INC.
801 S. FIFTH STREET, SUITE 202
ST. CHARLES, MO 63801
TEL: (636) 947-0607 FAX: (636) 947-2448

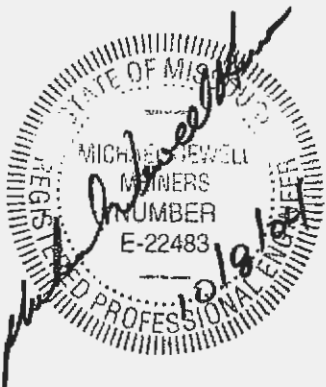
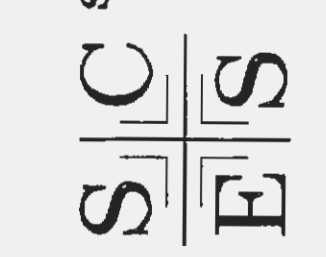

ORDER NO.	030649
DATE	08/13/04
D-5	