

FLUSHING HYDRANT DETAIL
NOT TO SCALE

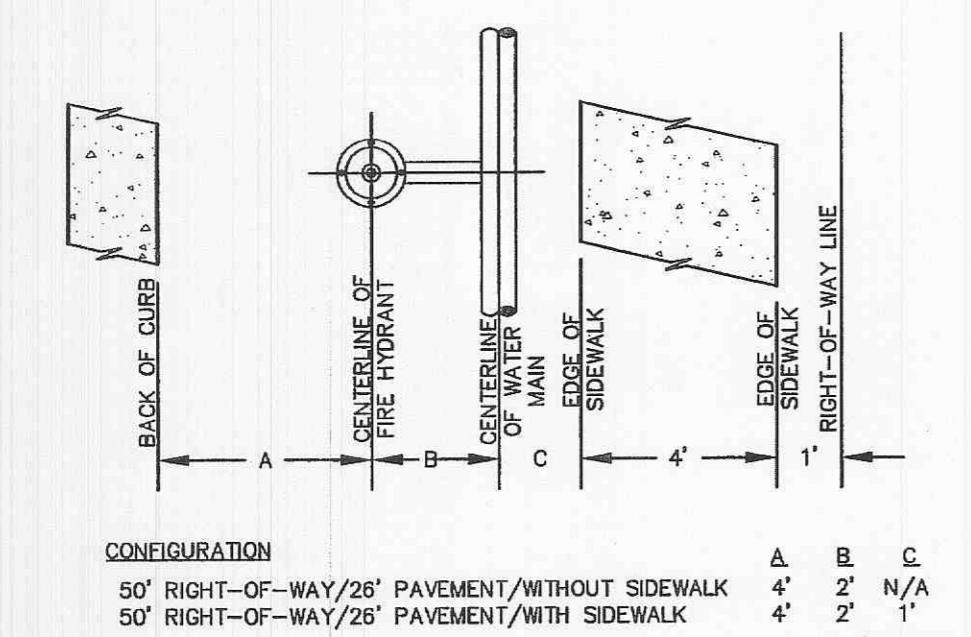

TYPICAL WATER MAIN AND FIRE HYDRANT LOCATIONS
NOT TO SCALE

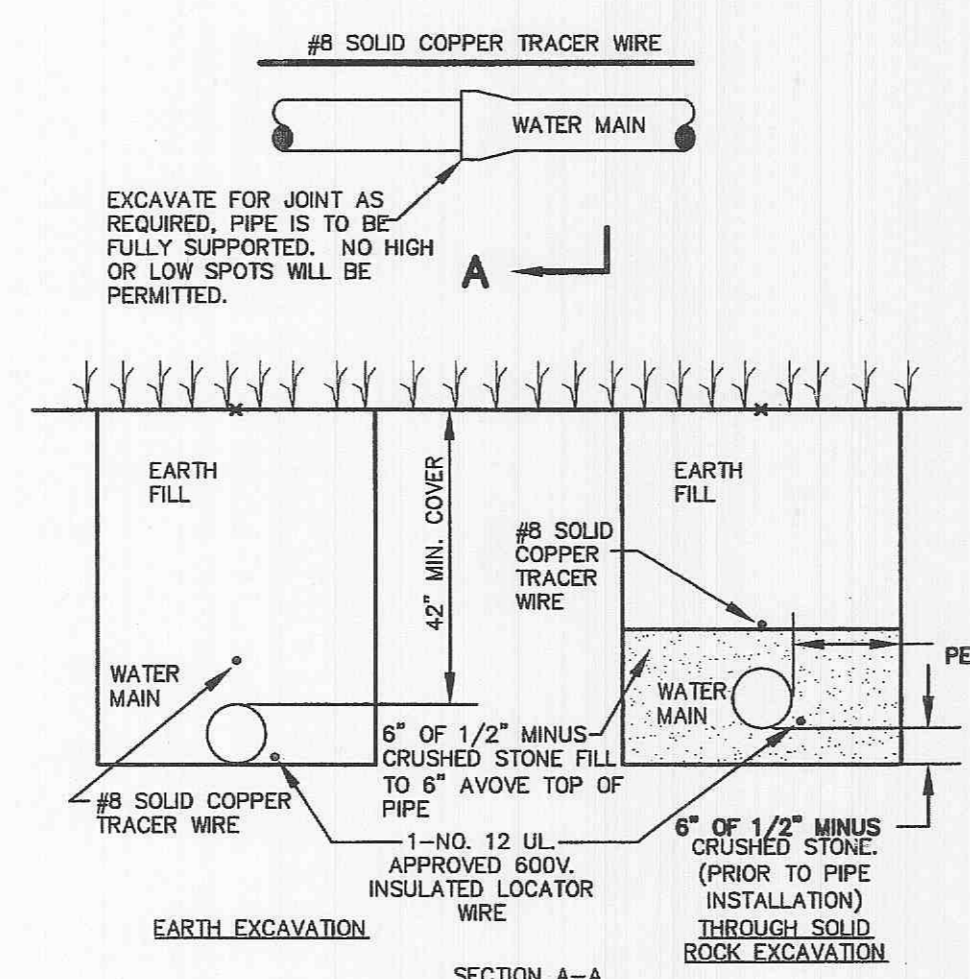

TYPICAL WATER MAIN INSTALLATION DETAILS
NOT TO SCALE

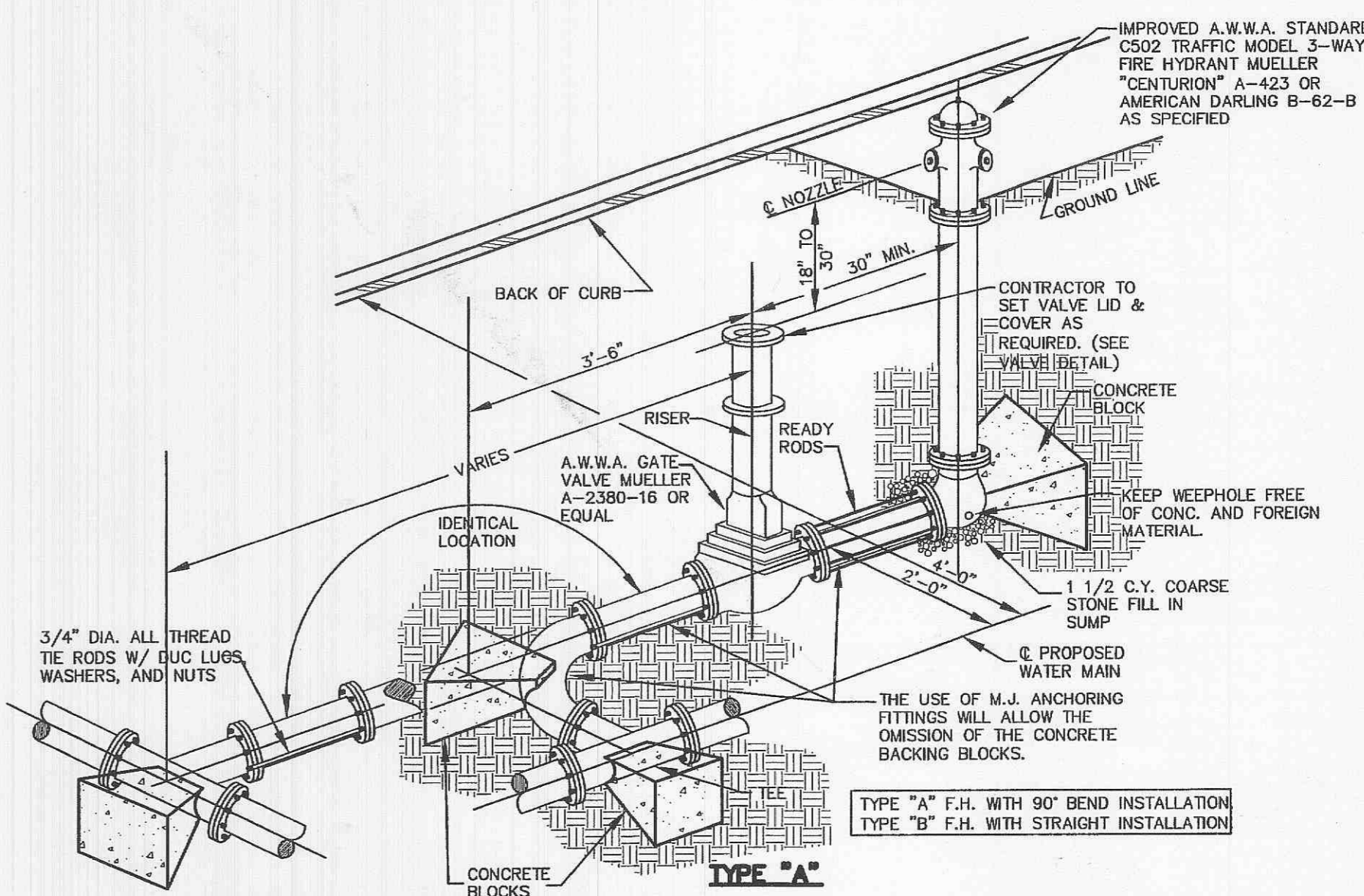

FIRE HYDRANT DETAIL
NOT TO SCALE

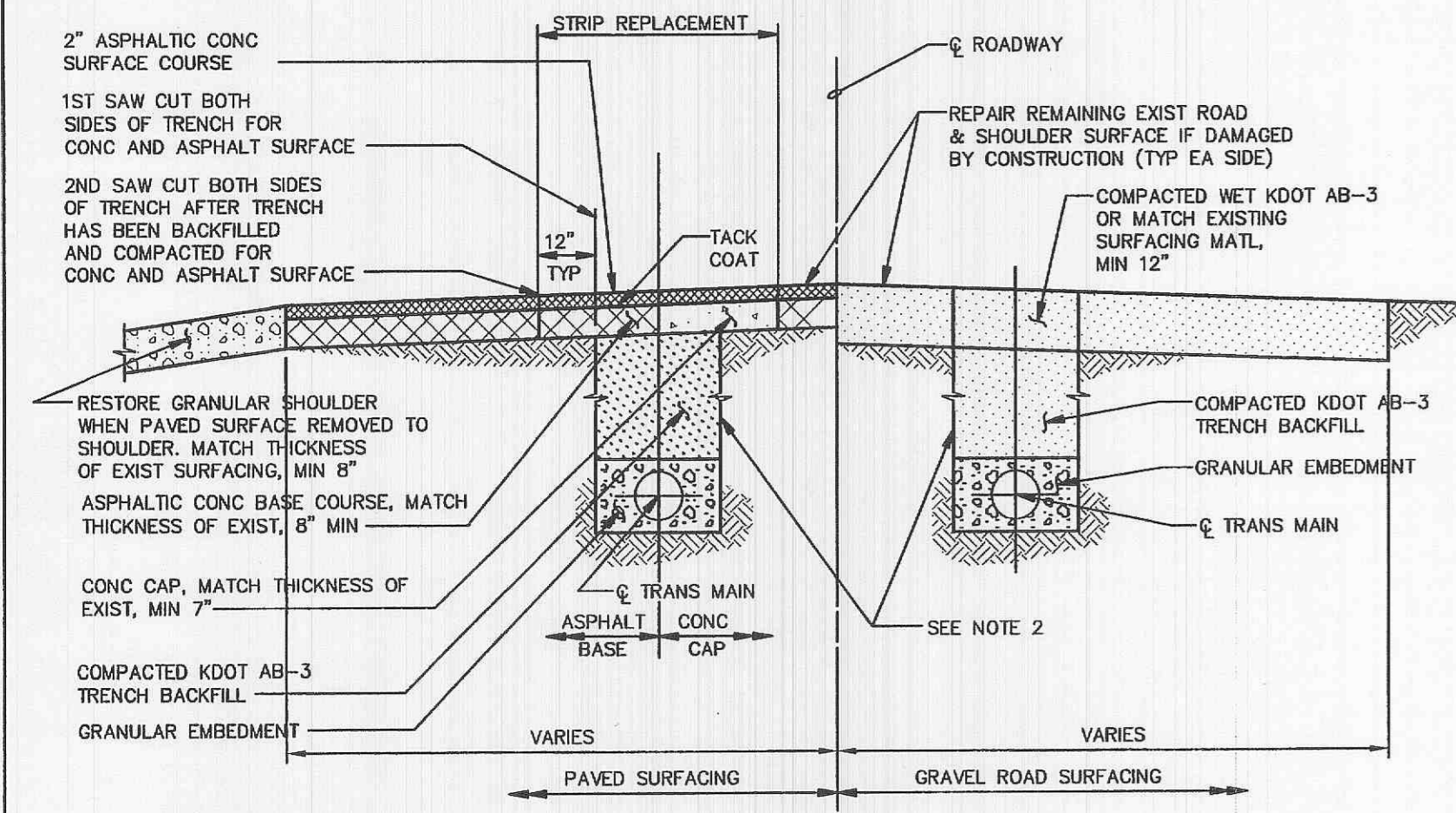

STREET TRENCHING DETAIL AND CROSSING SECTION
NOT TO SCALE

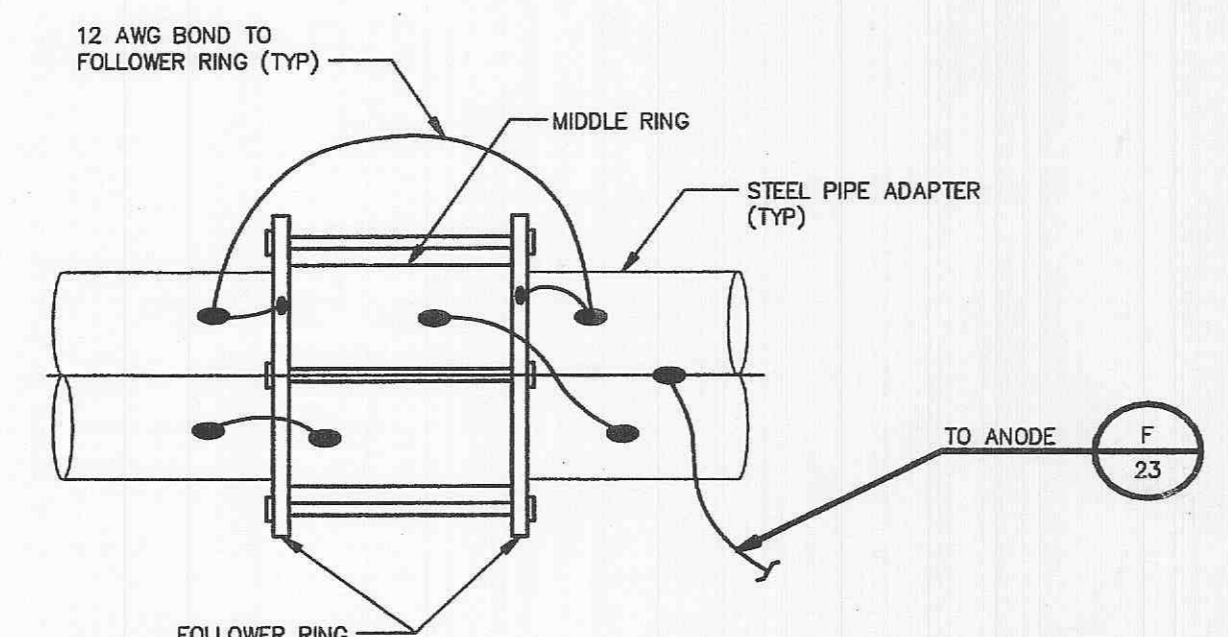

JOINT BONDING OF STEEL PIPE ADAPTERS FOR PCCP ALTERNATIVE
NOT TO SCALE

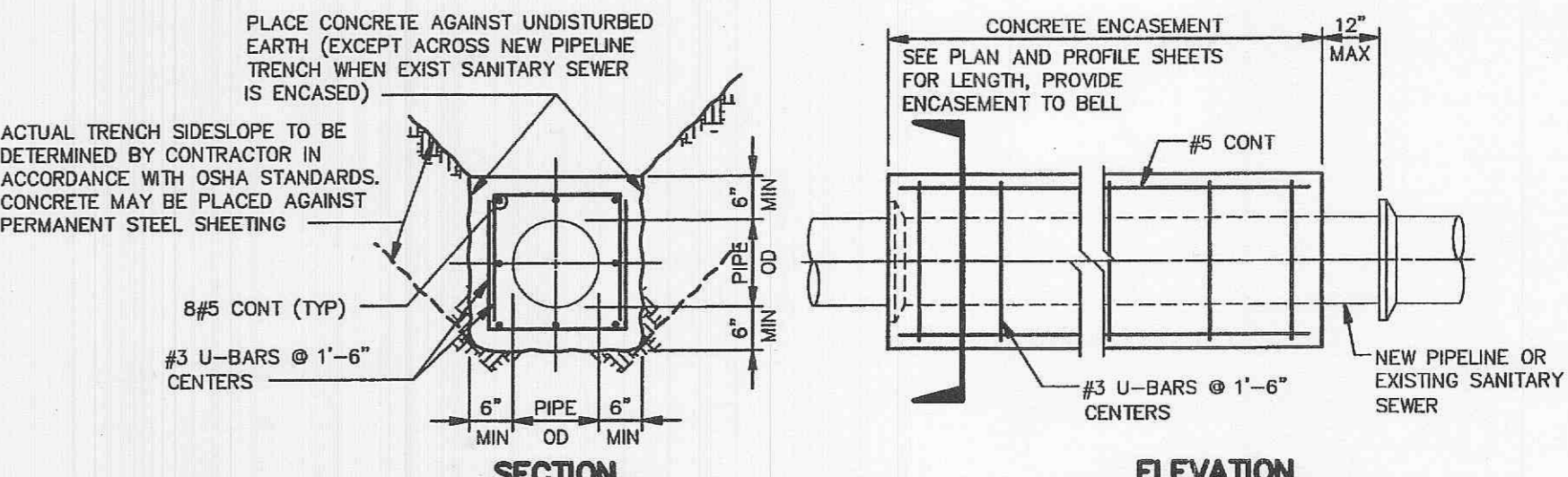

CONCRETE ENCASEMENT
NOT TO SCALE

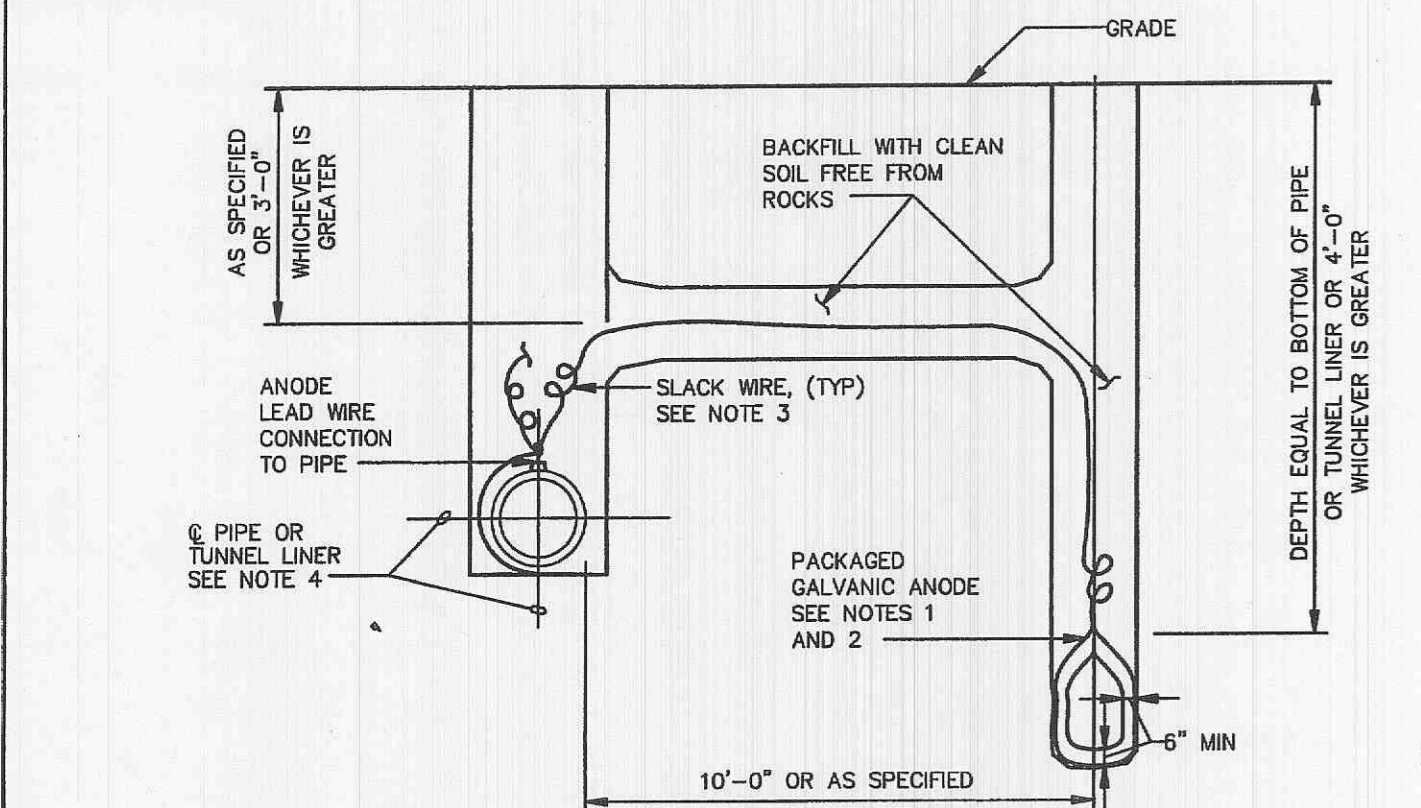

ANODE INSTALLATION FOR STEEL PIPE ADAPTERS FOR PCCP ALTERNATIVE AND FOR TUNNEL LINERS
NOT TO SCALE

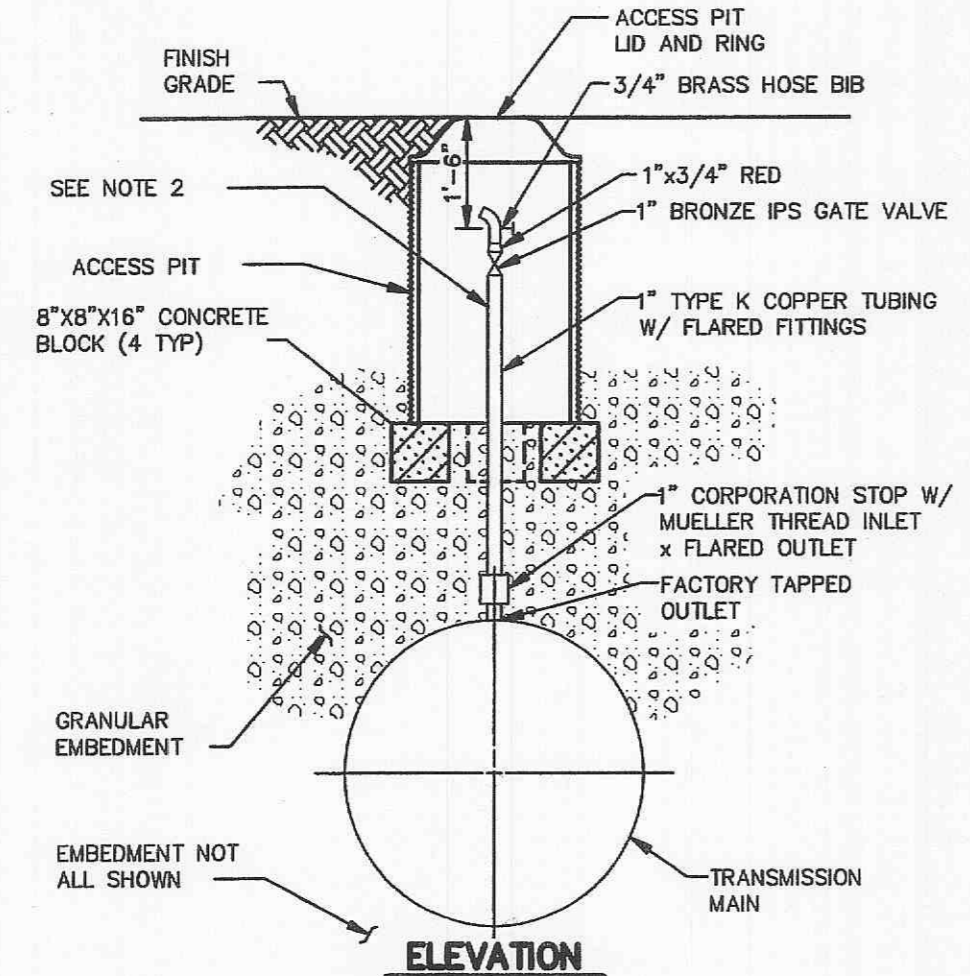

MANUAL AIR RELEASE VALVE ASSEMBLY
NOT TO SCALE

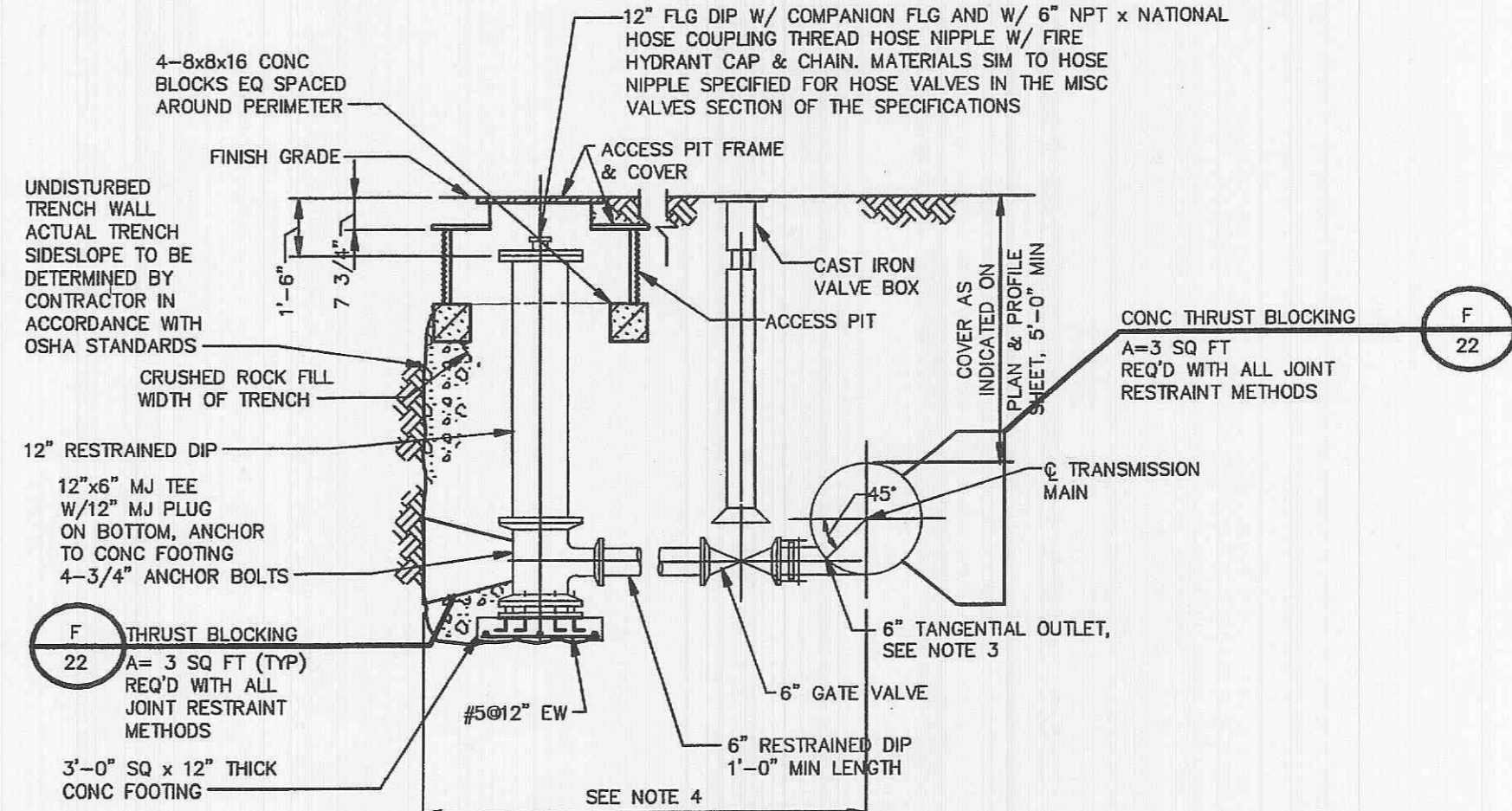

BLOWOFF FACILITY
NOT TO SCALE

MAGNOLIA
WATERLINE DETAILS 2

CITY OF FALLON
COMMUNITY DEVELOPMENT
DESIGN DIVISION
O'FALLON, MISSOURI

ST. CHARLES ENGINEERING & SURVEYING, INC.
801 S. FIFTH STREET, SUITE 202
ST. CHARLES, MO 63301
TEL: (636) 947-0607 FAX: (636) 947-2448



DISCLAIMER OF RESPONSIBILITY
I HEREBY CERTIFY THAT THE DRAWINGS HEREON
WAS PREPARED BY MYSELF OR UNDER MY CLOSE PERSONAL SUPERVISION AND I AM A LICENSED PROFESSIONAL ENGINEER IN THE STATE OF MISSOURI. I AM NOT PROVIDING ANY SPECIFIC DESIGN OR CONSTRUCTION ADVICE. THE USER OF THESE DRAWINGS SHALL BE RESPONSIBLE FOR OBTAINING ALL NECESSARY PERMITS AND FOR THE ACCURACY OF THE INFORMATION PROVIDED TO ME BY THE CLIENT. THIS DOCUMENT IS NOT TO BE USED FOR ANY OTHER PROJECT OR FOR THE CONSTRUCTION OF ANY STRUCTURE WITHOUT THE WRITTEN CONSENT OF ST. CHARLES ENGINEERING & SURVEYING, INC.

DESIGNED: _____
CHECKED: _____
DATE: _____
PROJECT NO.: _____
SHEET _____
OF _____



ORDER NO. 08-0498
DATE 12/1/08
D9