

1 CONCRETE SWALE
Not To Scale

NOTE: S. W. F. = STORM WATER FLOW

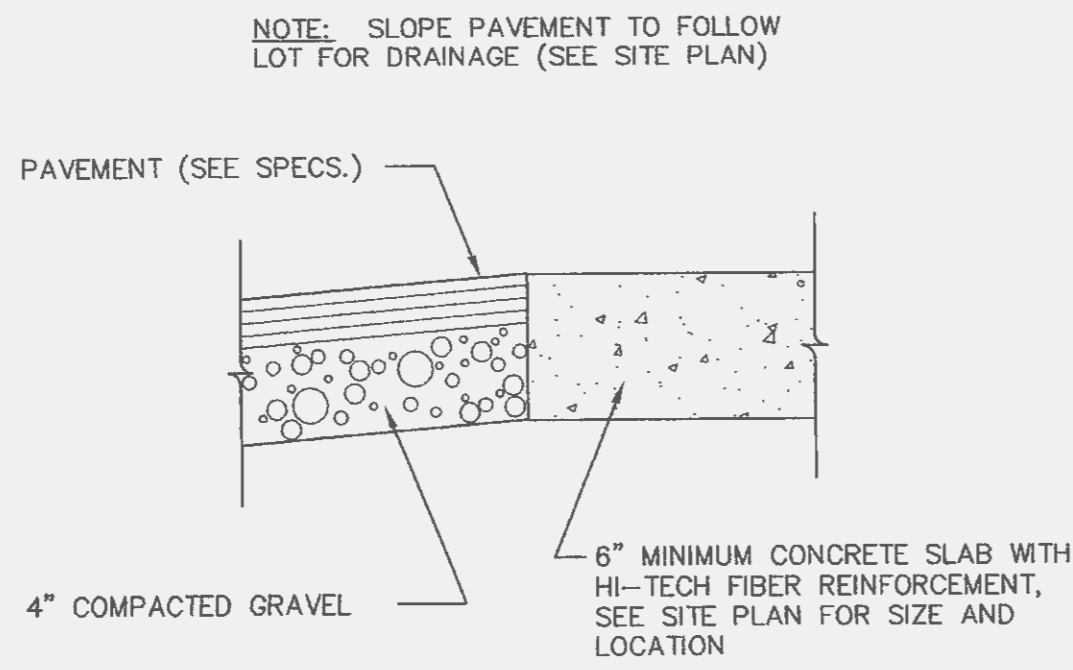

2 DRIVE-THRU PAD DETAIL
Not To Scale

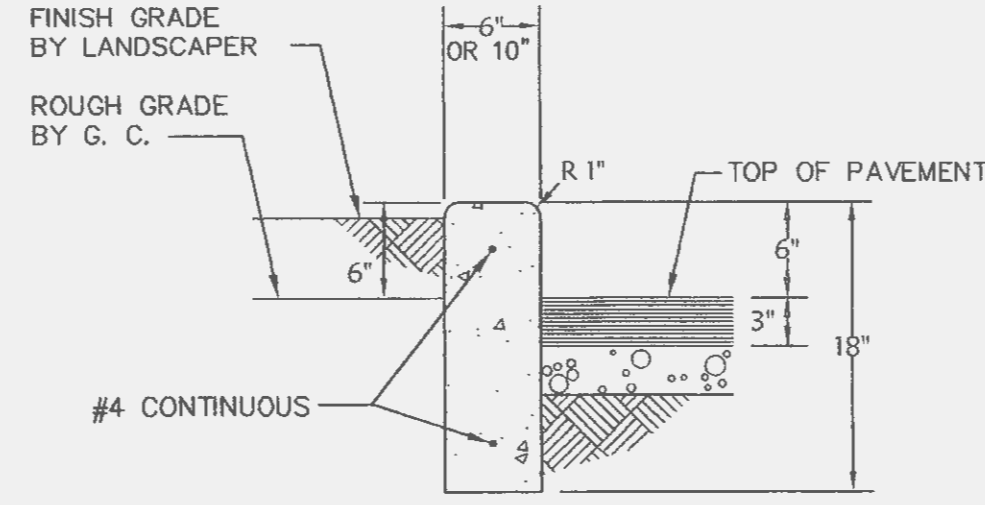

3 CONC. CURB - 6" X 18" & 10" X 18"
Not To Scale

.028 C. Y. CONC. PER L. F. + REINF. FOR 6" X 18"
.046 C. Y. CONC. PER L. F. + REINF. FOR 10" X 18"

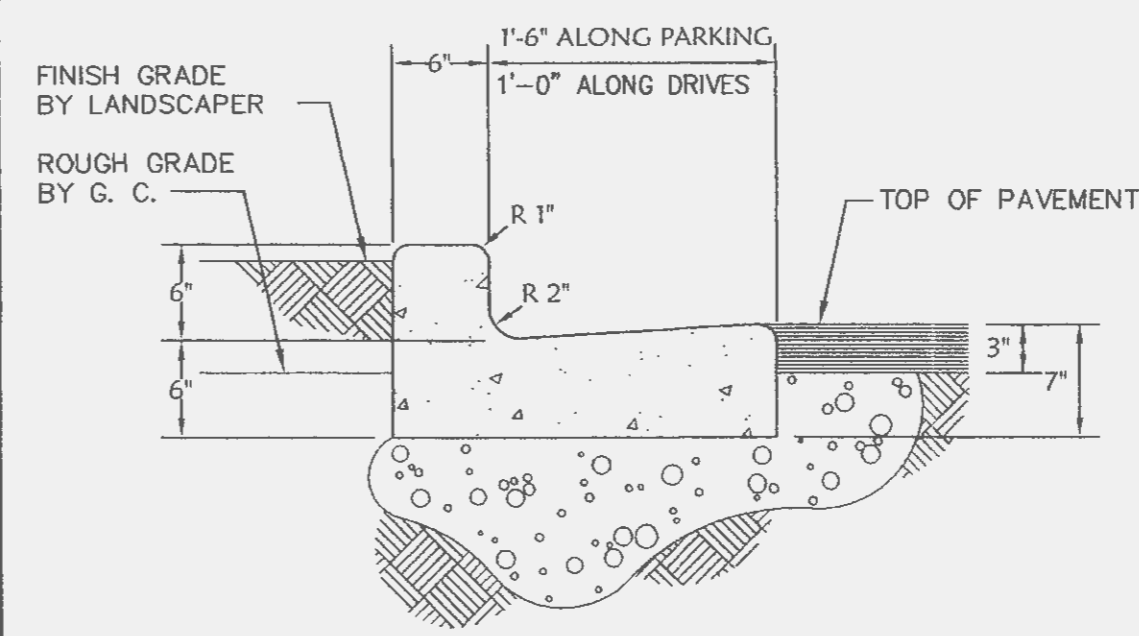

4 CONCRETE CURB & GUTTER
Not To Scale

.039 C. Y. CONC. PER L. F. FOR 12" GUTTER
.049 C. Y. CONC. PER L. F. FOR 18" GUTTER

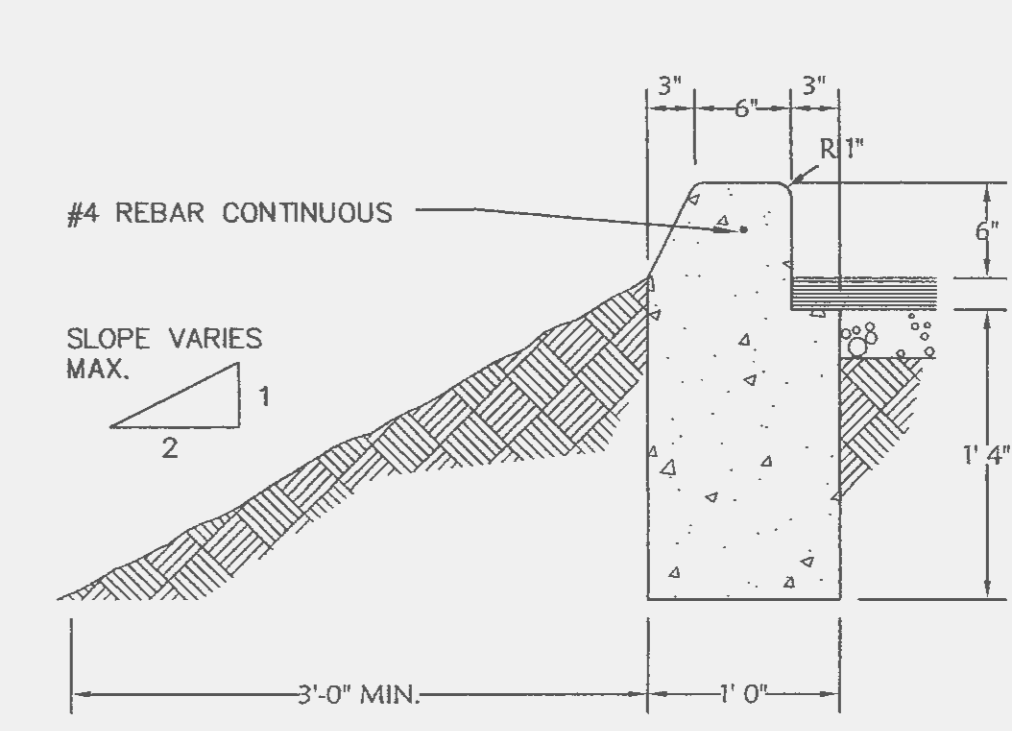

5 CURB AT TOP OF SLOPE
Not To Scale

NOTE: PROVIDE EXPANSION JOINTS @ 20'-0" O.C. (MAX.)

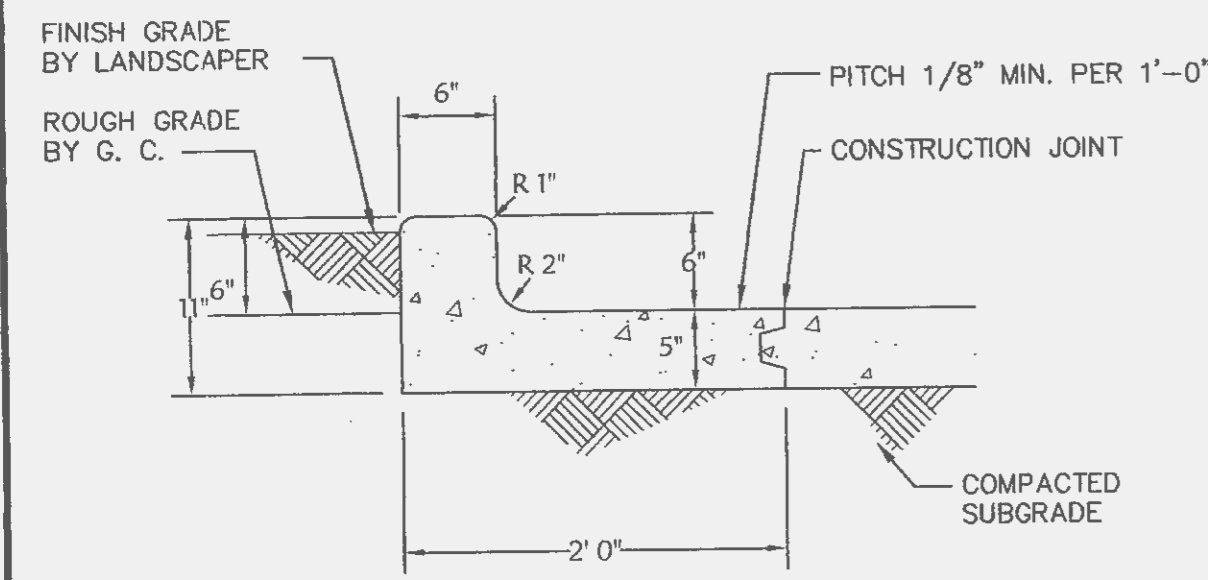

6 INTEGRAL CURB FOR CONC. LOTS
Not To Scale

.017 C. Y. CONC. PER L. F. FOR 6" X 11" UPRIGHT SECTION

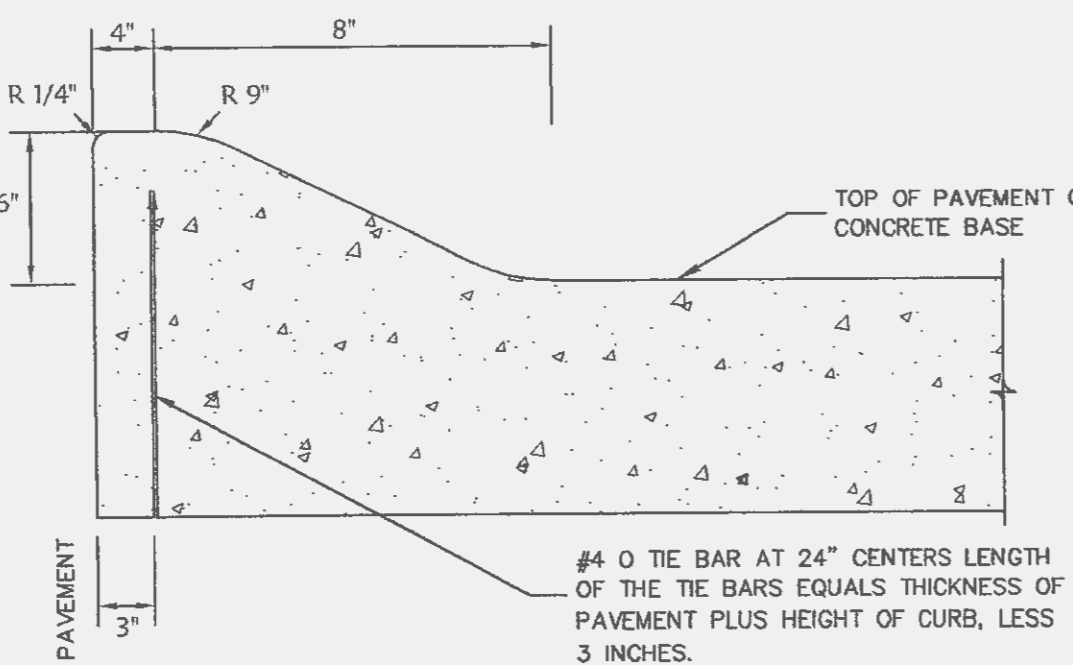

7 "TYPE M" MOUNTABLE CURB
Not To Scale

NOTE: CURB SHOWN TO BE USED IN CASES WHERE A TRUCK MIGHT ROLL ON TOP OF IT

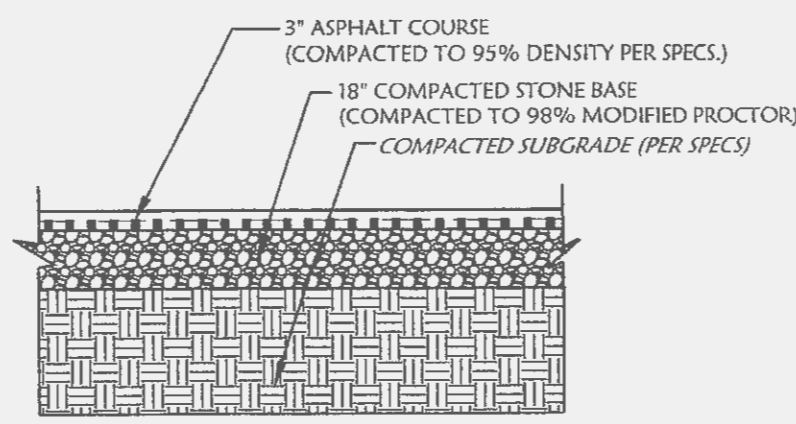

8 STANDARD DUTY ASPHALT PAVEMENT SECTION
(REFER TO McDONALD'S PROJECT MANAGER FOR FURTHER DETAILS)

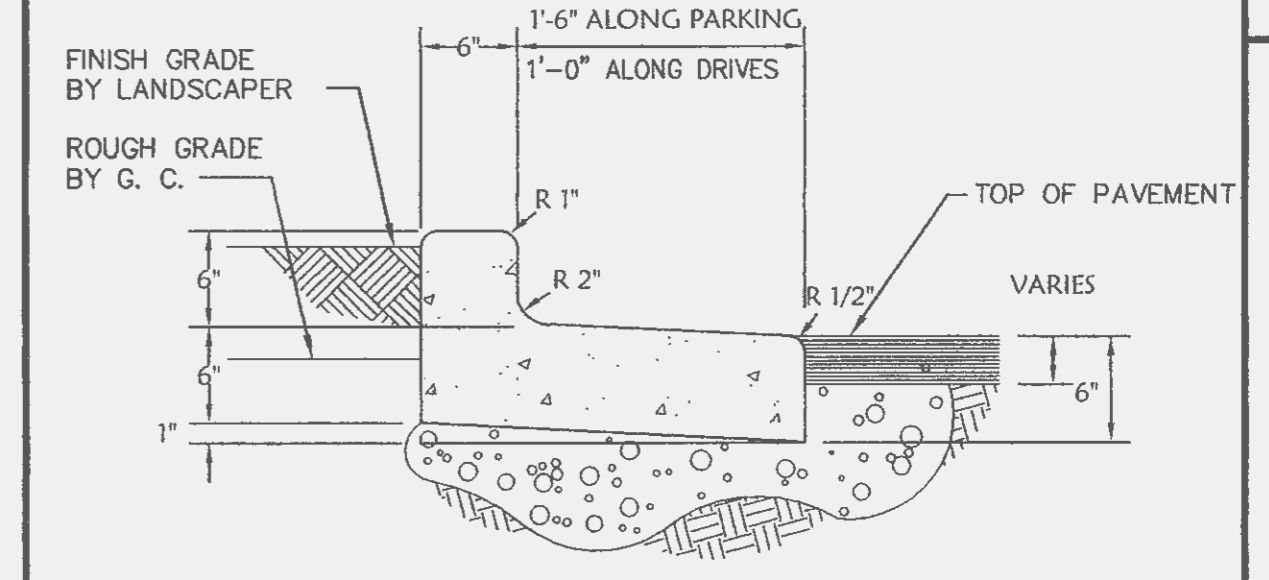

10 DRY CONCRETE CURB & GUTTER
Not To Scale

.039 C. Y. CONC. PER L. F. FOR 12" GUTTER
.049 C. Y. CONC. PER L. F. FOR 18" GUTTER

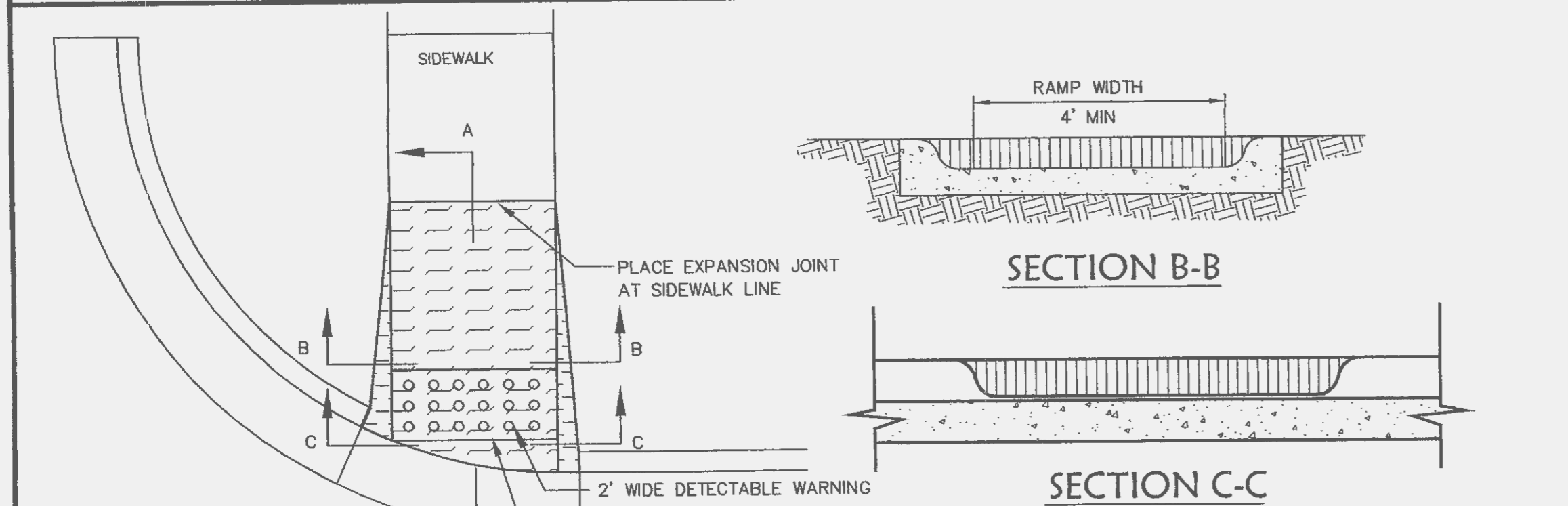

11 SIDEWALK WITH RAMP CONDITIONS
Not To Scale

*ALL HANDICAP RAMPS TO BE CONCRETE.

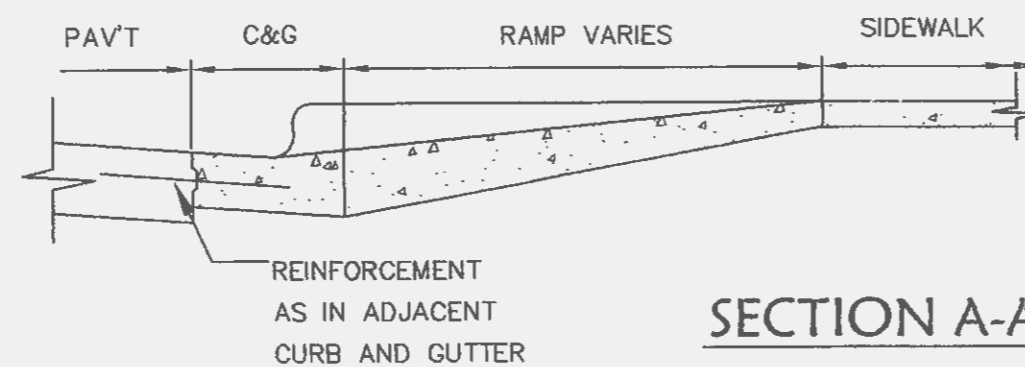

SECTION A-A

- SIDEWALK RAMP NOTES:**
1. SIDEWALK RAMP LOCATION DETERMINED FROM THE INTERSECTION OF THE EXTENSION OF BACK OF SIDEWALK AND BACK OF CURB & GUTTER.
 2. KEY ALL CONSTRUCTION JOINTS OR USE TIE BARS #4 EPOXY COATED @ 12" O.C.
 3. LONGITUDINAL JOINT SPACING TO MATCH WIDTH OF SIDEWALK.
 4. ISOLATION JOINTS SHALL BE PLACED WHERE WALK ABUTS DRIVEWAYS AND SIMILAR STRUCTURES, AND 250' CENTER MAX.
 5. SIDEWALK RAMP SHALL BE LENGTHENED TO PROVIDE ADA COMPLIANCE SLOPE BUT NEED NOT EXCEED 15'.
 6. ADA MAXIMUM RAMP SLOPE = 1"/FT. ADA MAXIMUM CROSS SLOPE = 2%
 7. DETECTABLE WARNINGS TO COMPLY WITH ADA REQUIREMENTS.

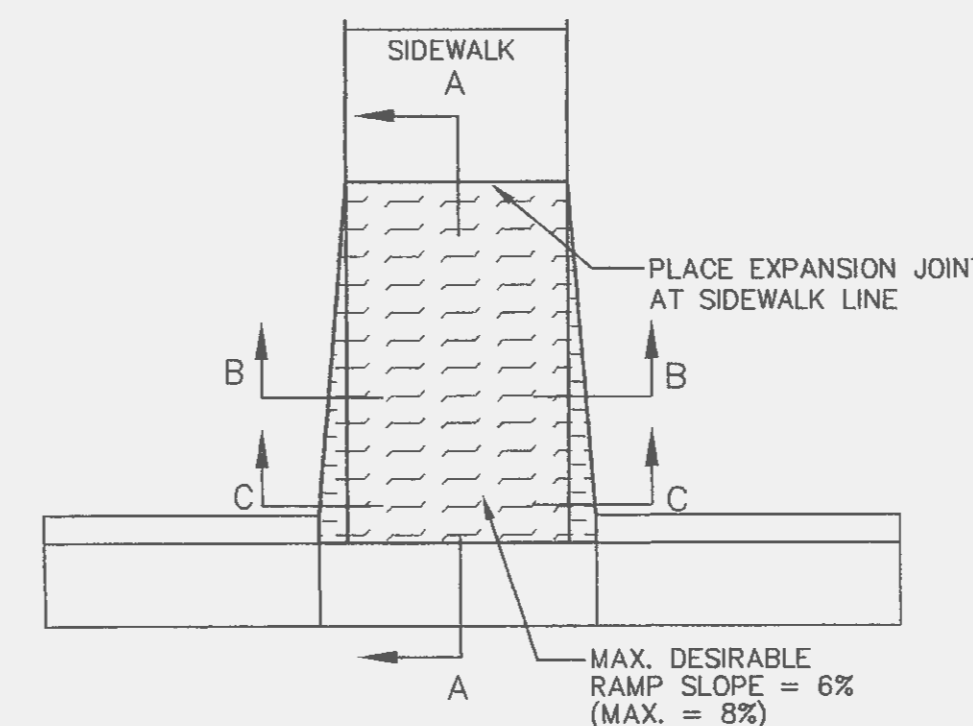

ADA STANDARD FOR ACCESSIBLE DESIGN:

- 4.29.2* DETECTABLE WARNINGS ON WALKING SURFACES. DETECTABLE WARNINGS SHALL CONSIST OF RAISED TRUNCATED DOMES WITH A DIAMETER OF NOMINAL 0.9 IN (23 MM), A HEIGHT OF NOMINAL 0.2 IN (5 MM) AND A CENTER-TO-CENTER SPACING OF NOMINAL 2.35 IN (60 MM) AND SHALL CONTRAST VISUALLY WITH ADJOINING SURFACES, EITHER LIGHT-ON-DARK, OR DARK-ON-LIGHT.

LEGEND

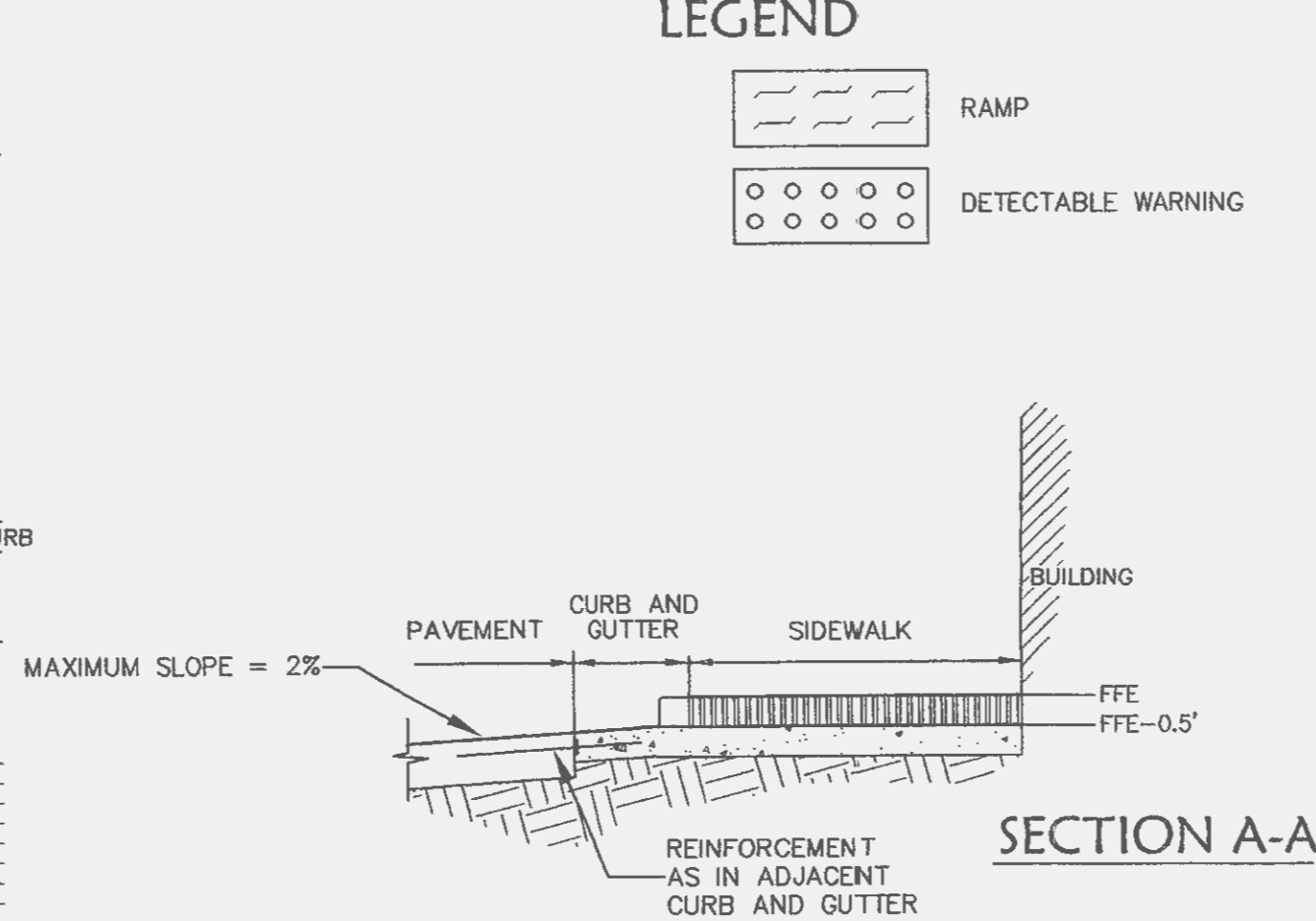
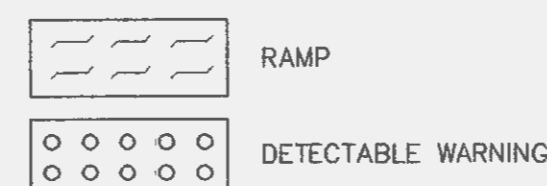

SECTION A-A

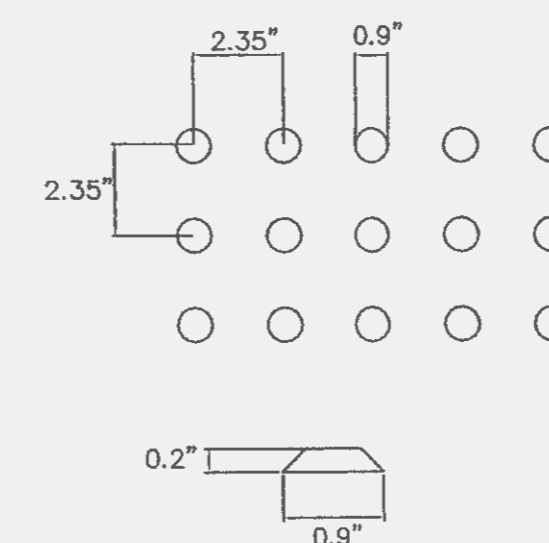

DETECTABLE WARNING DOME SPACING AND SECTION
Not To Scale

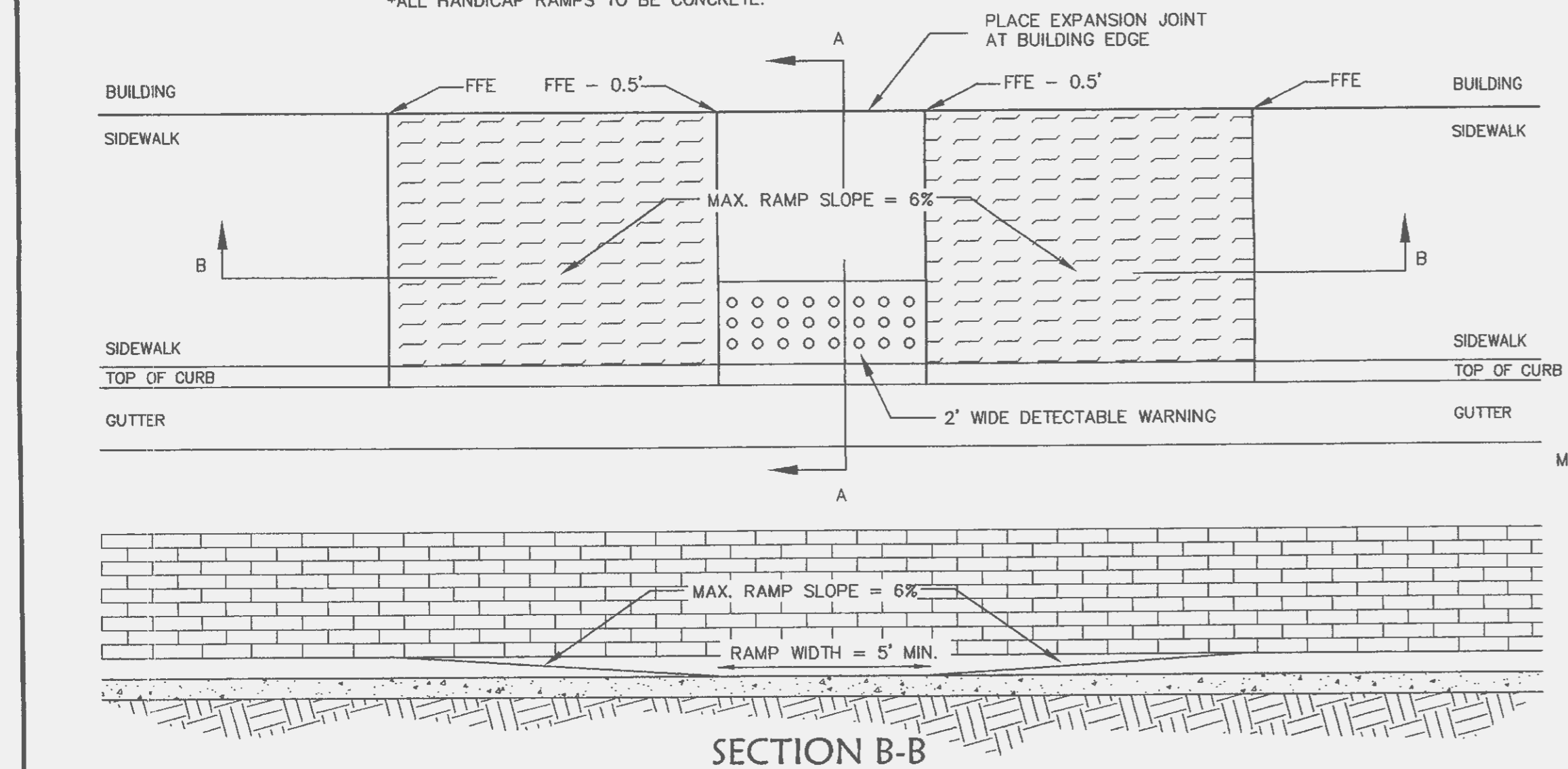

SECTION B-B

12 SIDEWALK WITH RAMP CONDITIONS
Not To Scale

DATE	REV	DESCRIPTION
12-18-06	1	REVISED SITE AND ADDED ROAD IMPROVEMENTS

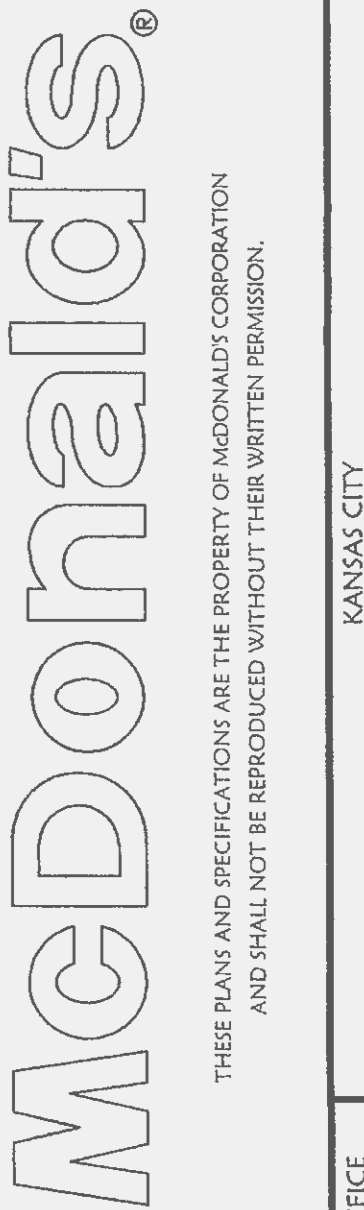
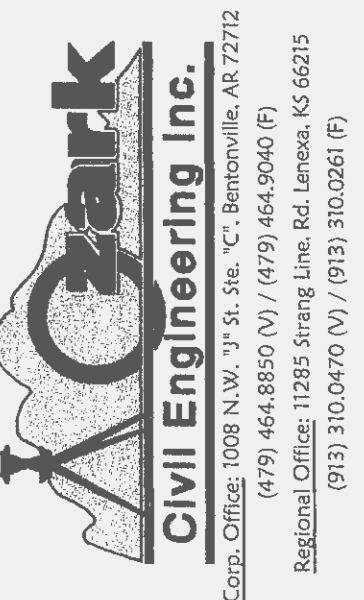

STATUS	DATE	BY
PRELIMINARY	-/-/-	-
PLAN CHECKED	-/-/-	-
AS-BUILT	-/-/-	-
PROJECT NO.	06-0620	

SD1