

ROUND PIPE	HORIZONTAL ELLIPTICAL PIPE		
	Payline Width of Trench (Feet)	Payline Width of Trench (Feet)	Payline Width of Trench (Feet)
4	2.8	2.33	3.20
6	2.8	2.33	3.46
8	2.8	2.33	3.70
10	2.8	2.33	3.98
12	2.8	2.33	3.98
15	3.2	2.47	4.89
18	3.5	2.92	5.63
21	3.8	3.25	6.41
24	4.2	3.50	7.39
27	4.5	3.75	8.18
30	4.9	4.08	9.30
33	5.3	4.42	10.53
36	5.6	4.67	11.43
39	DISCONTINUED		
42	6.3	5.25	13.38
48	7.0	5.87	16.19
54	7.7	6.42	18.19
60	8.4	7.00	20.73
66	9.1	7.58	23.45
72	9.8	8.17	26.37
78	10.5	8.75	29.39
84	11.2	9.33	32.27
90	11.9	9.92	35.80
96	12.6	10.50	38.37
102	13.3	11.08	42.99
108	14.0	11.67	46.75
114	14.7	12.25	50.66
120	15.4	12.83	54.72
126	16.1	13.42	58.92
132	16.8	14.00	63.27
144	18.2	15.17	72.40

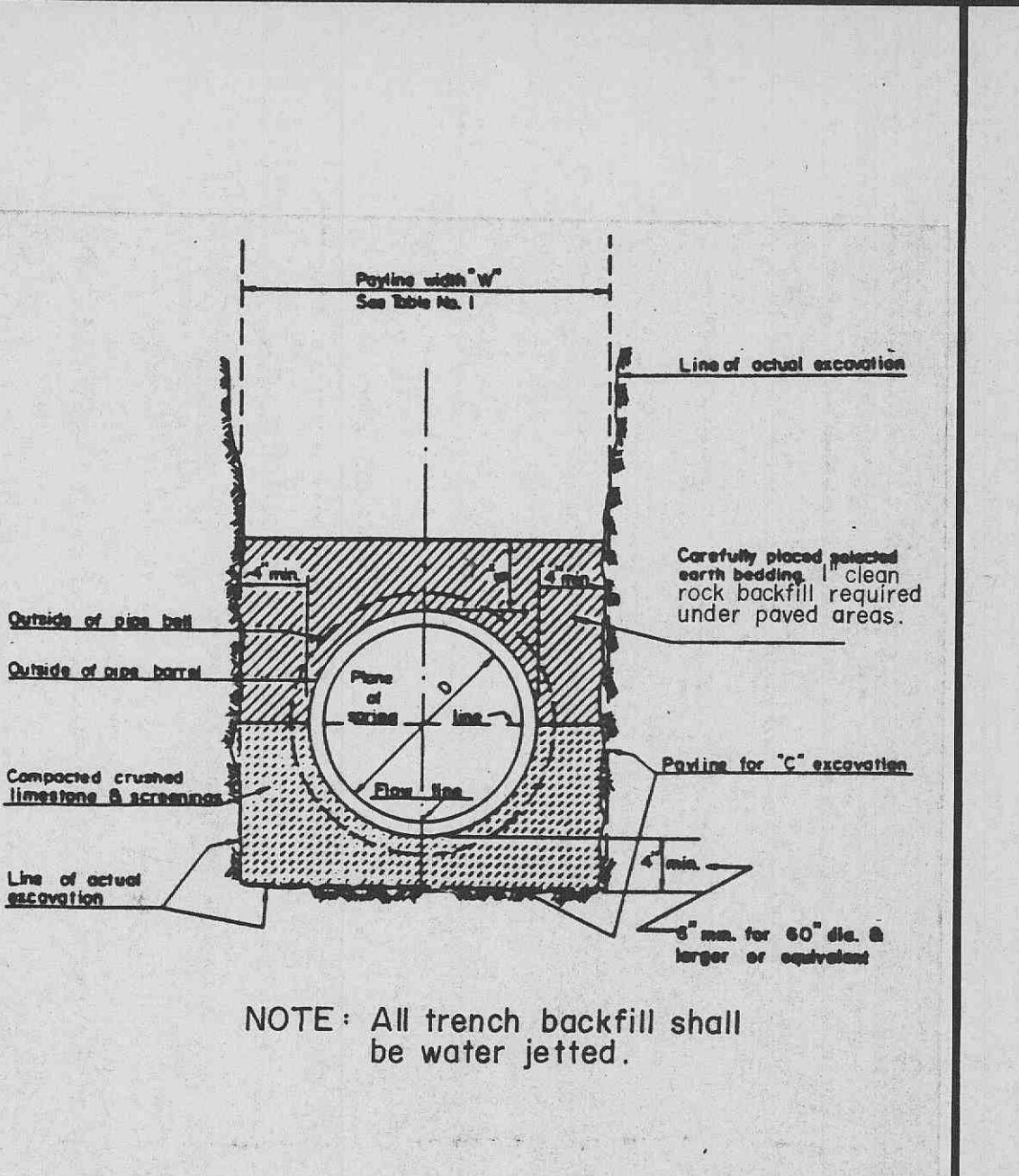
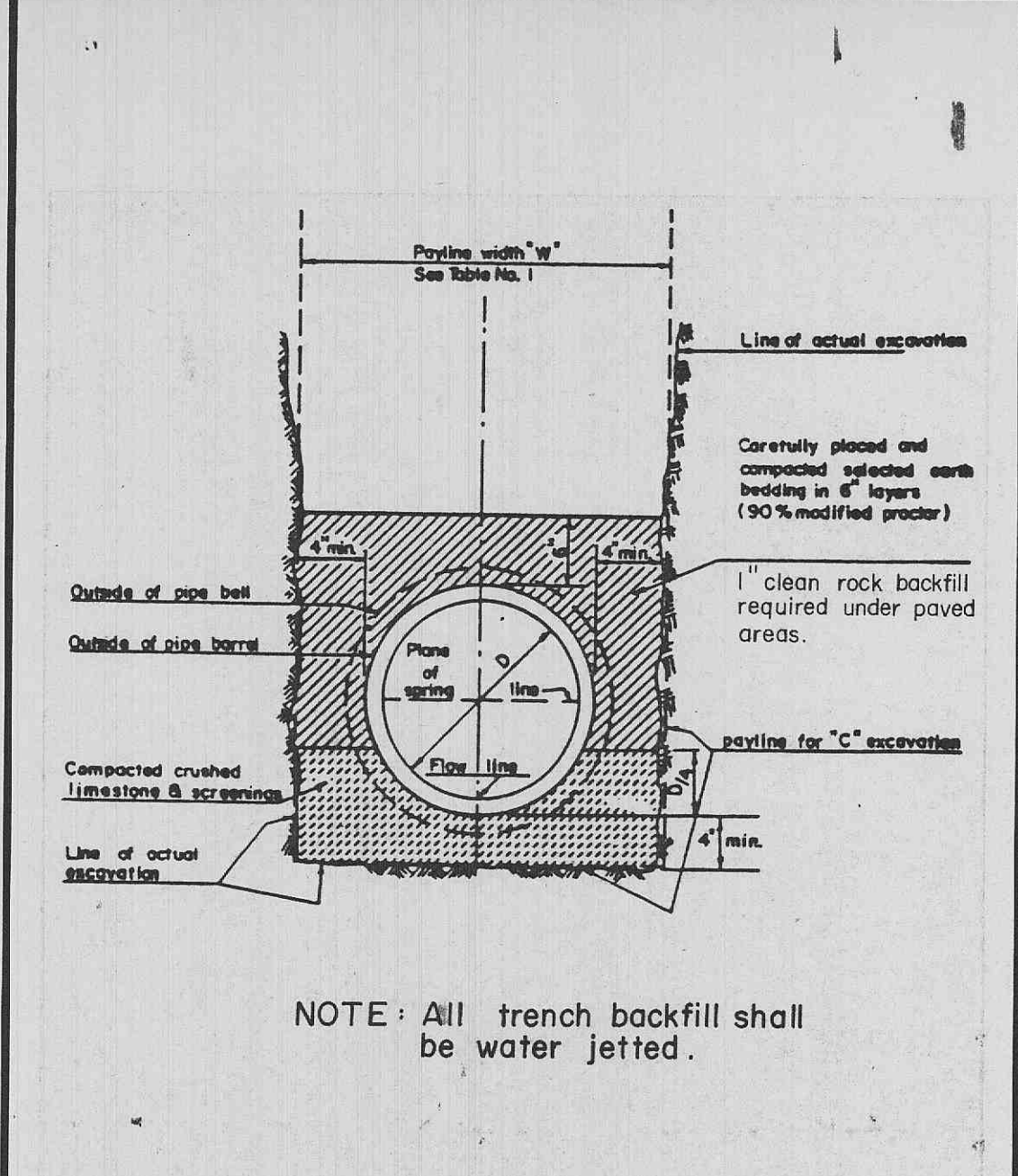
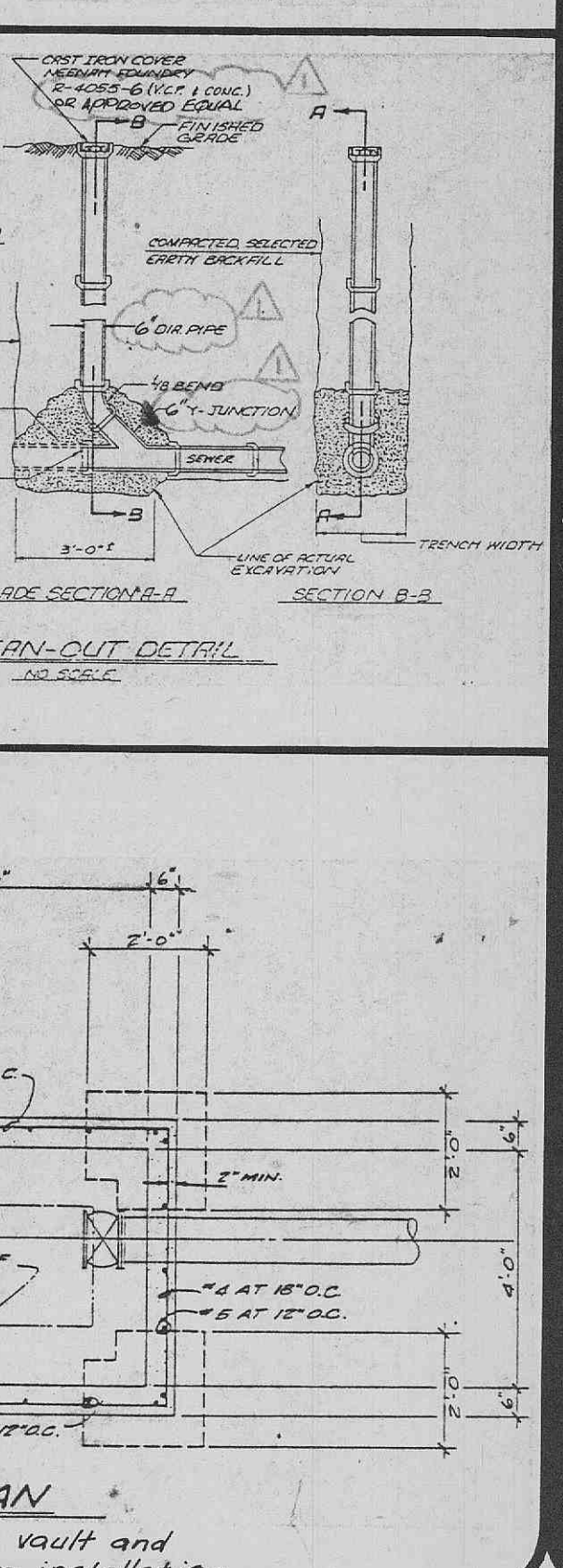
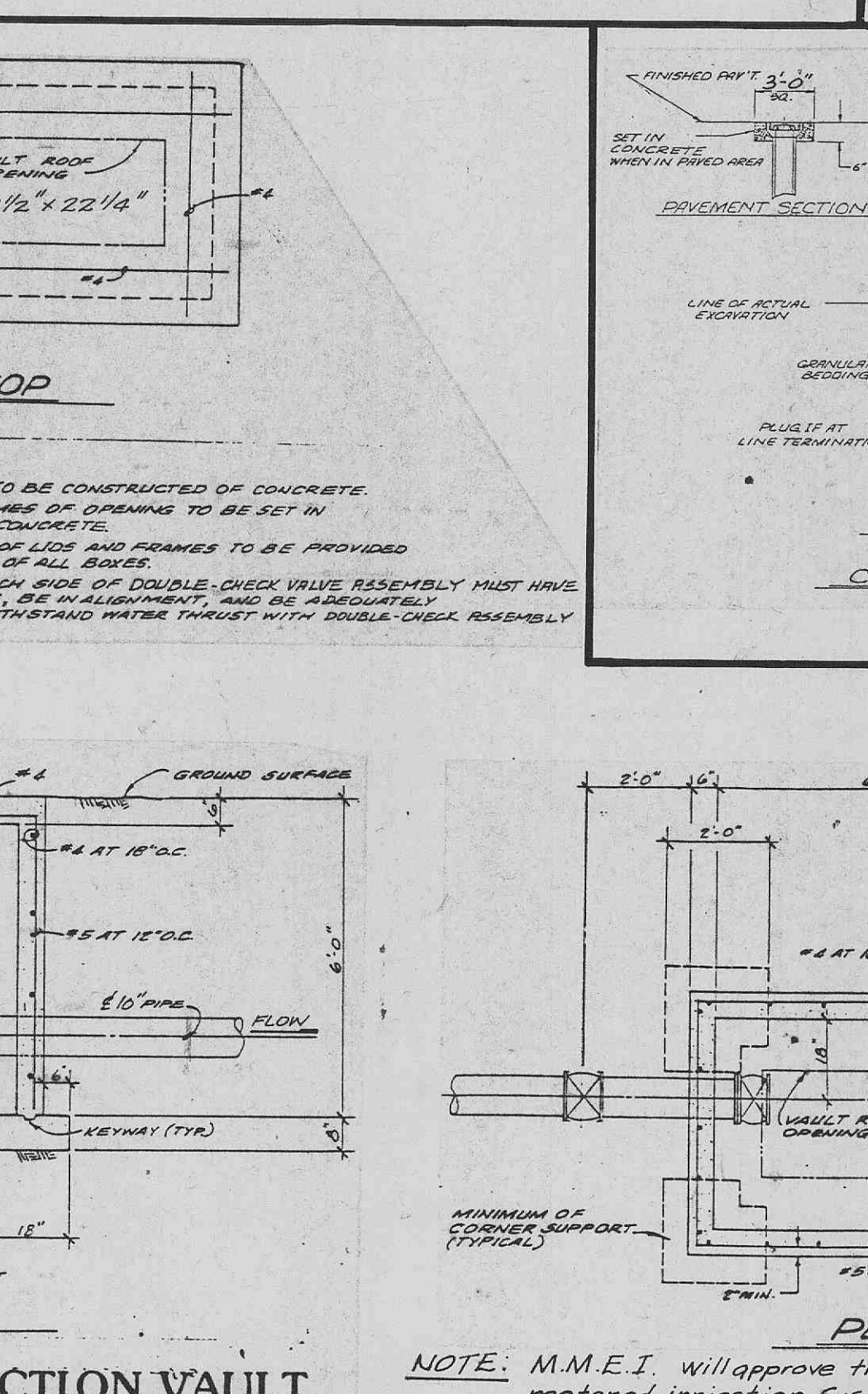
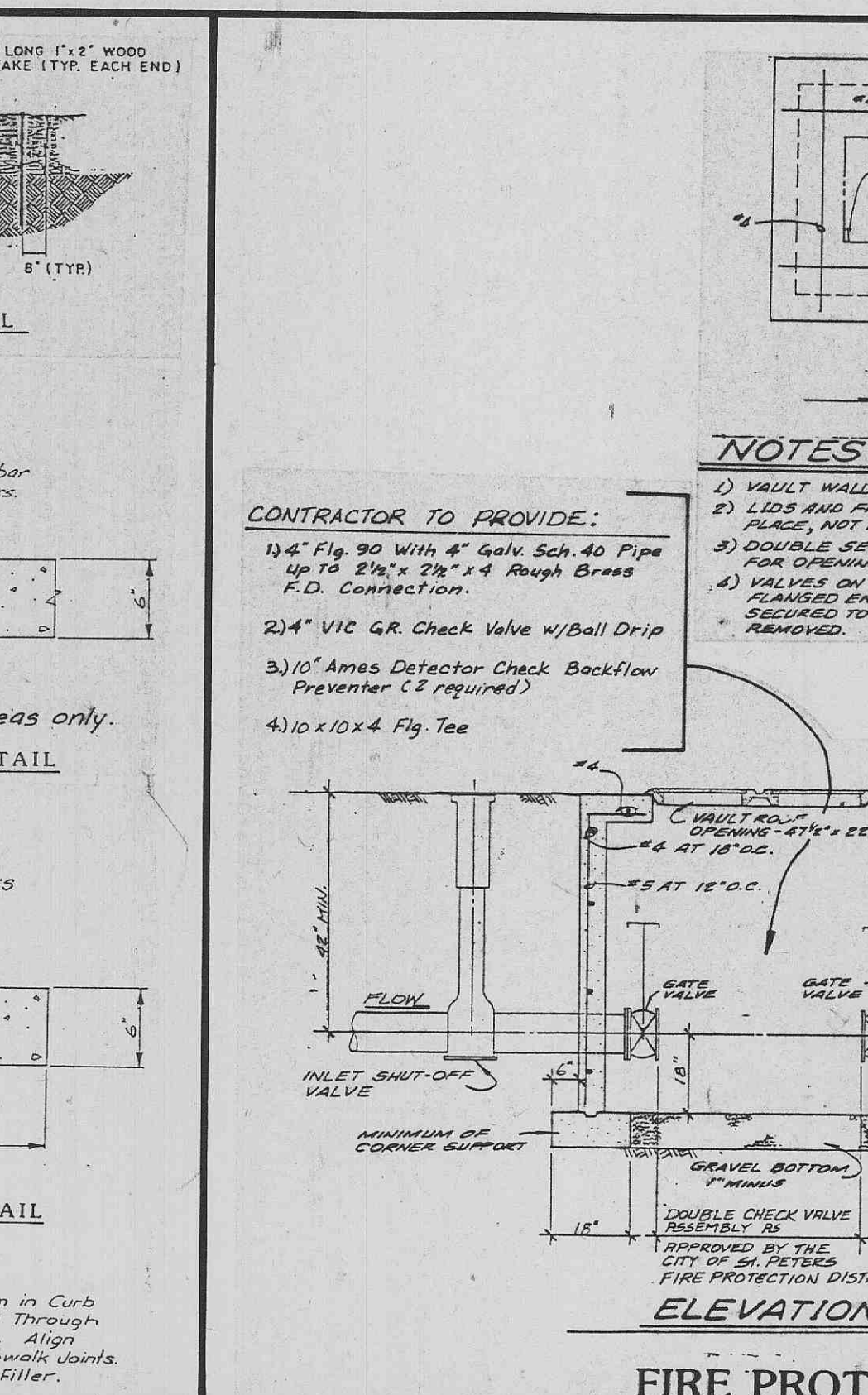
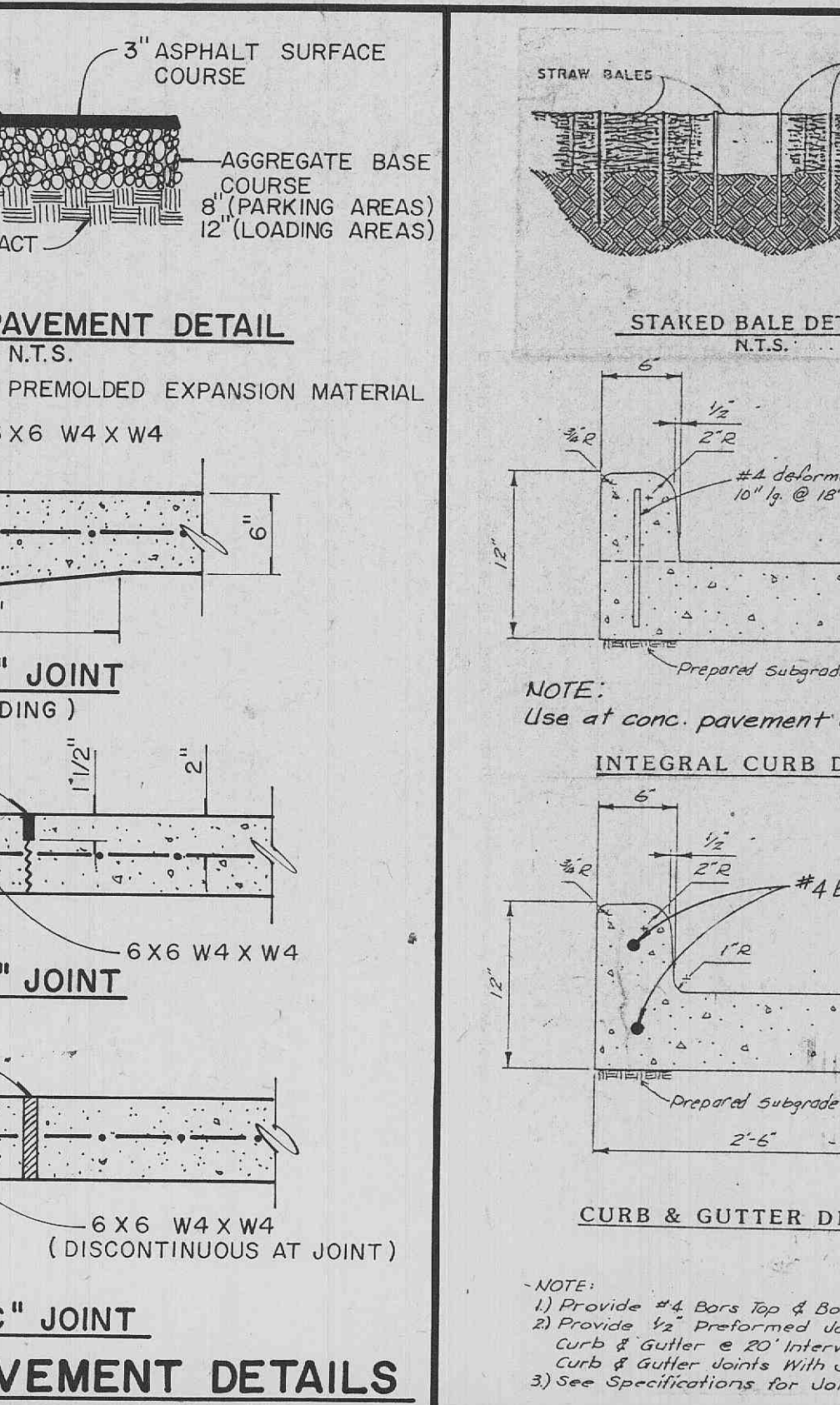
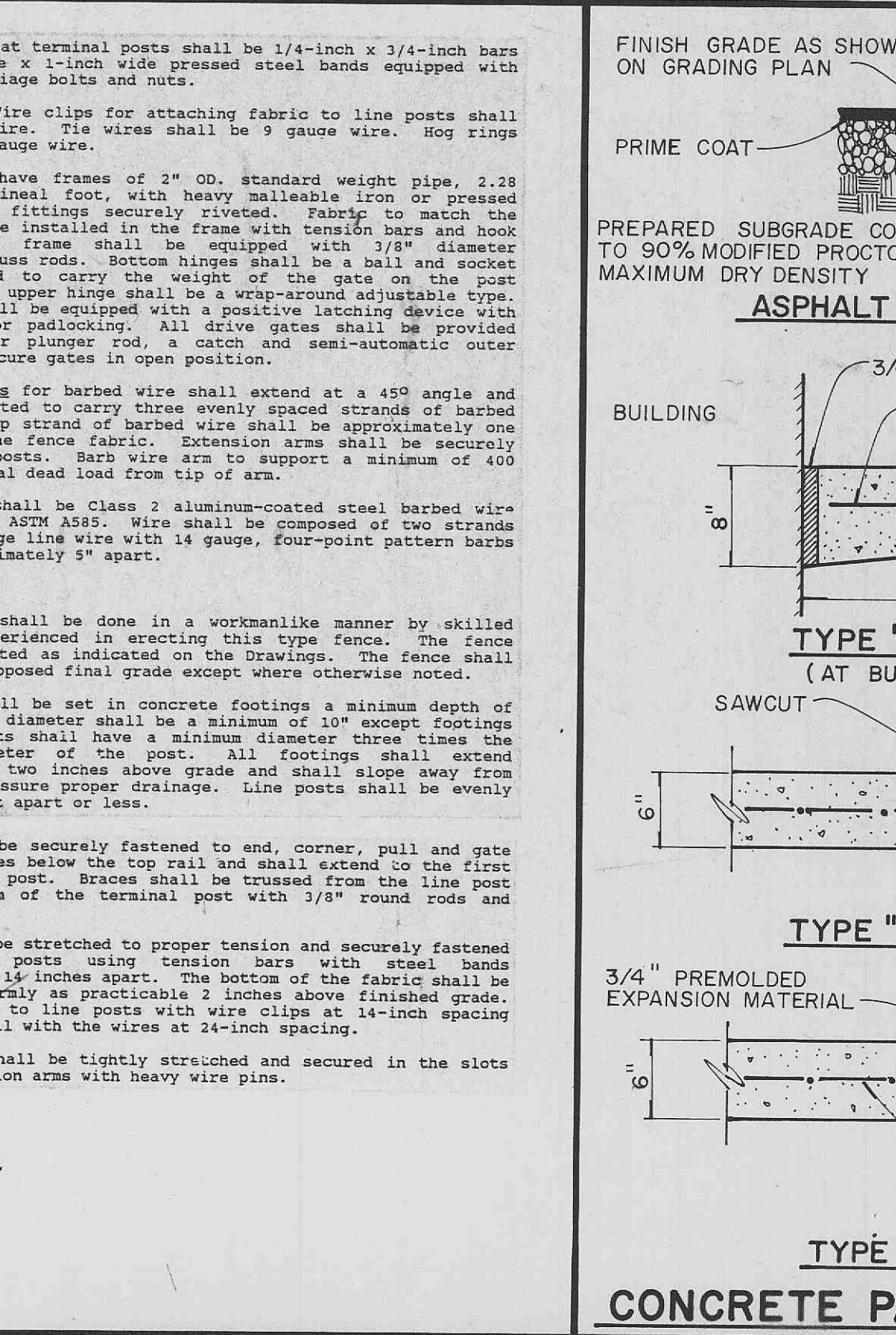
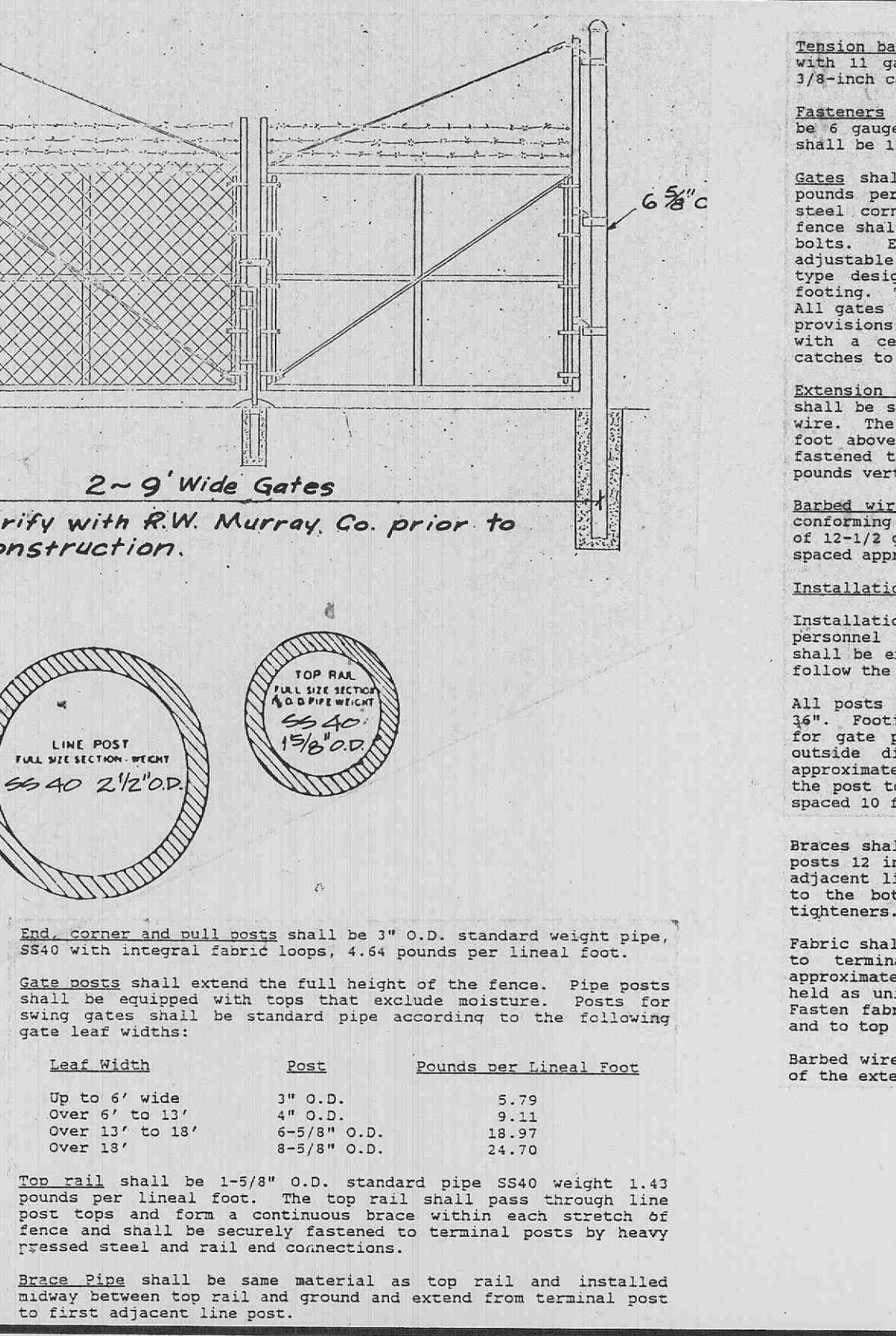
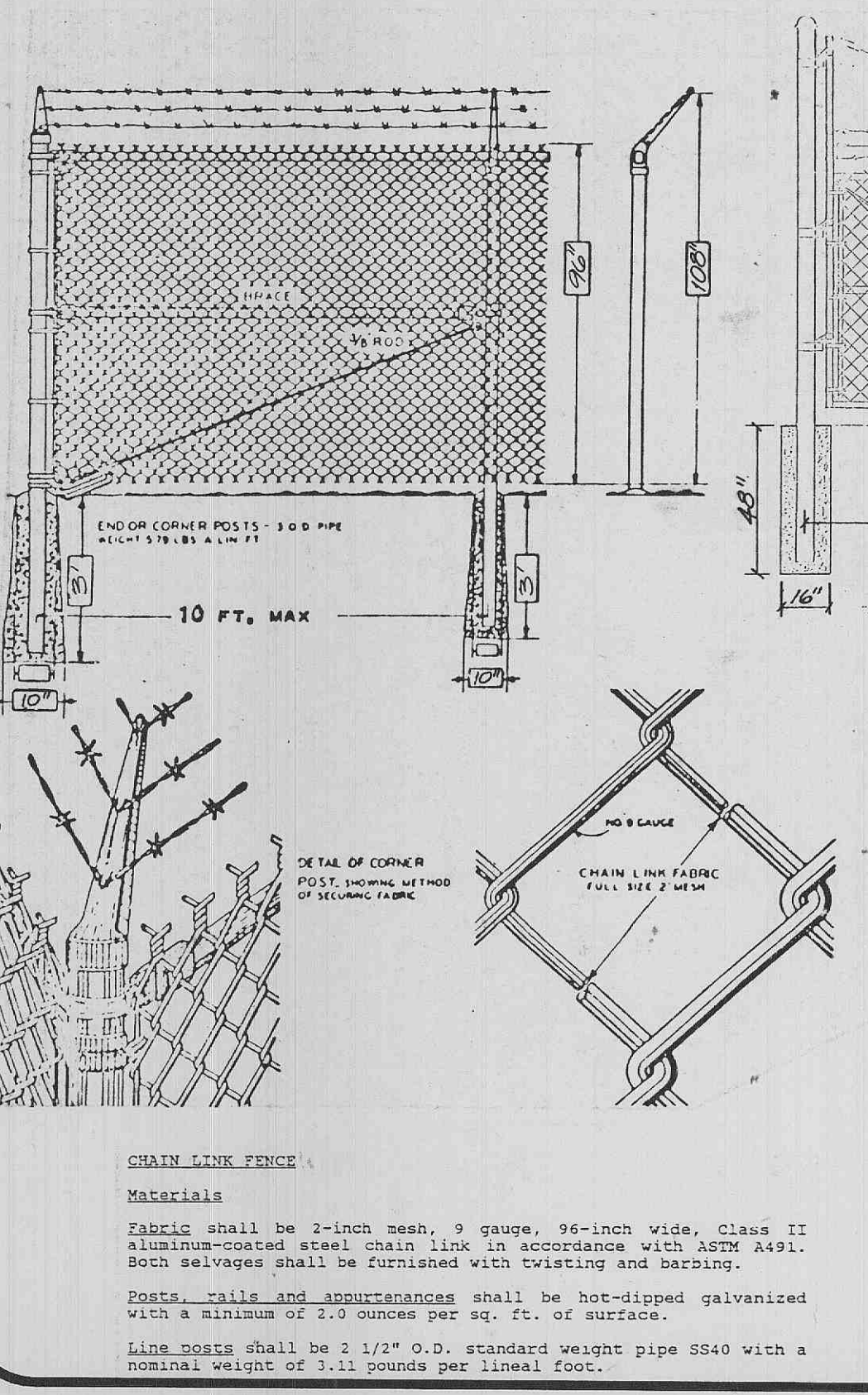
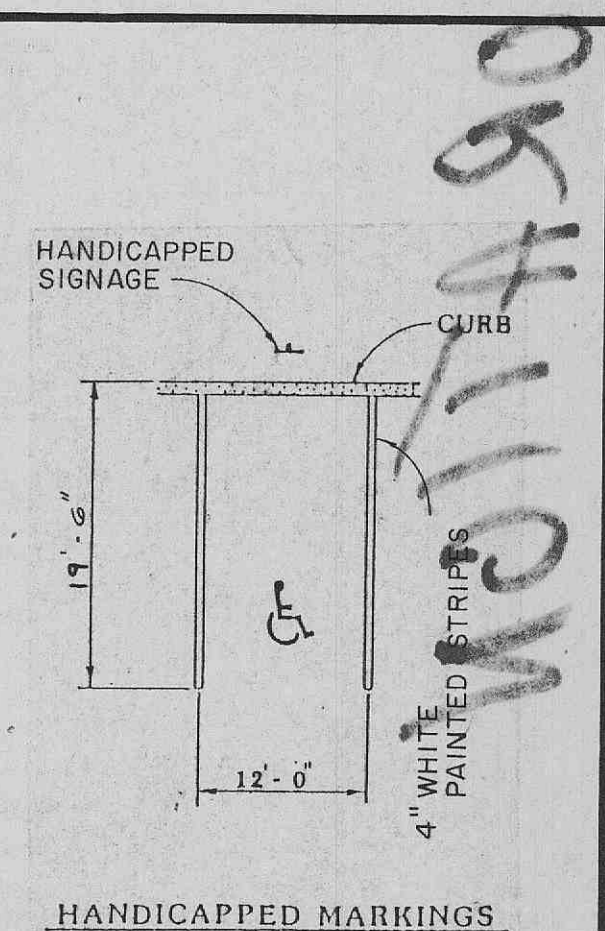
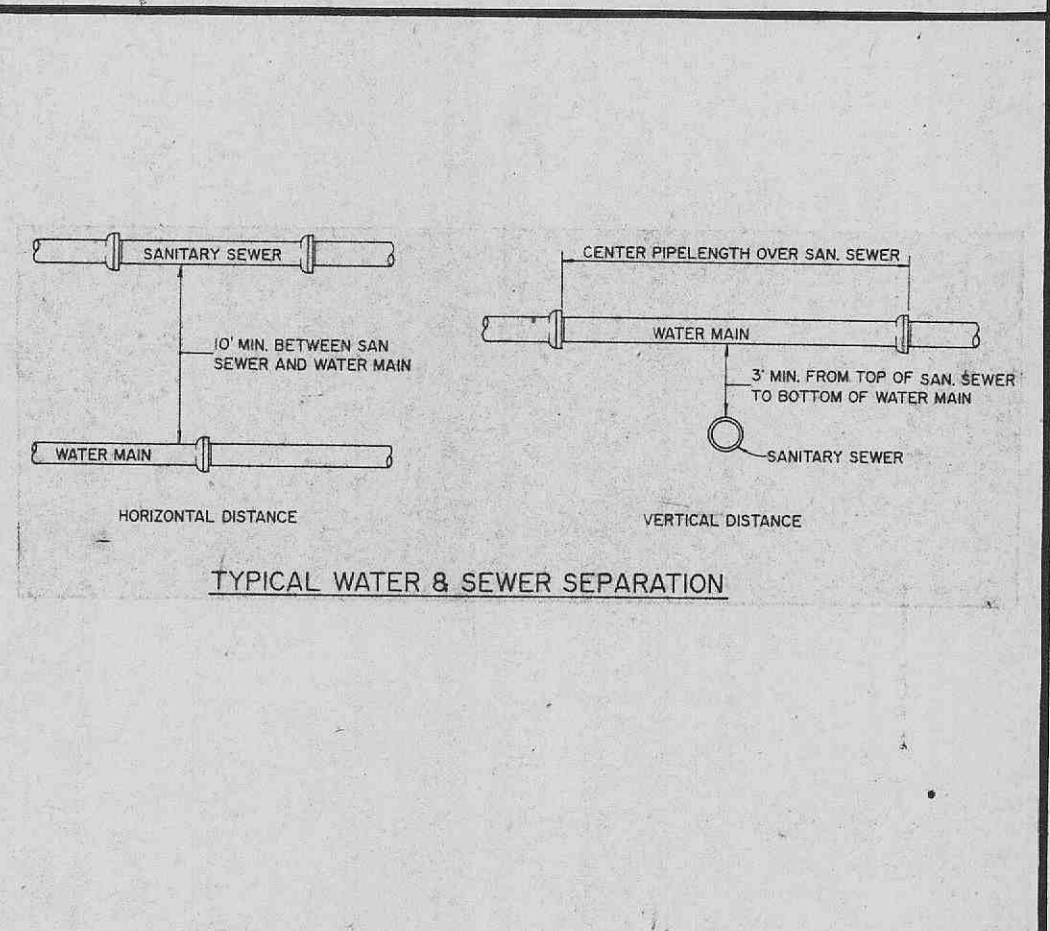
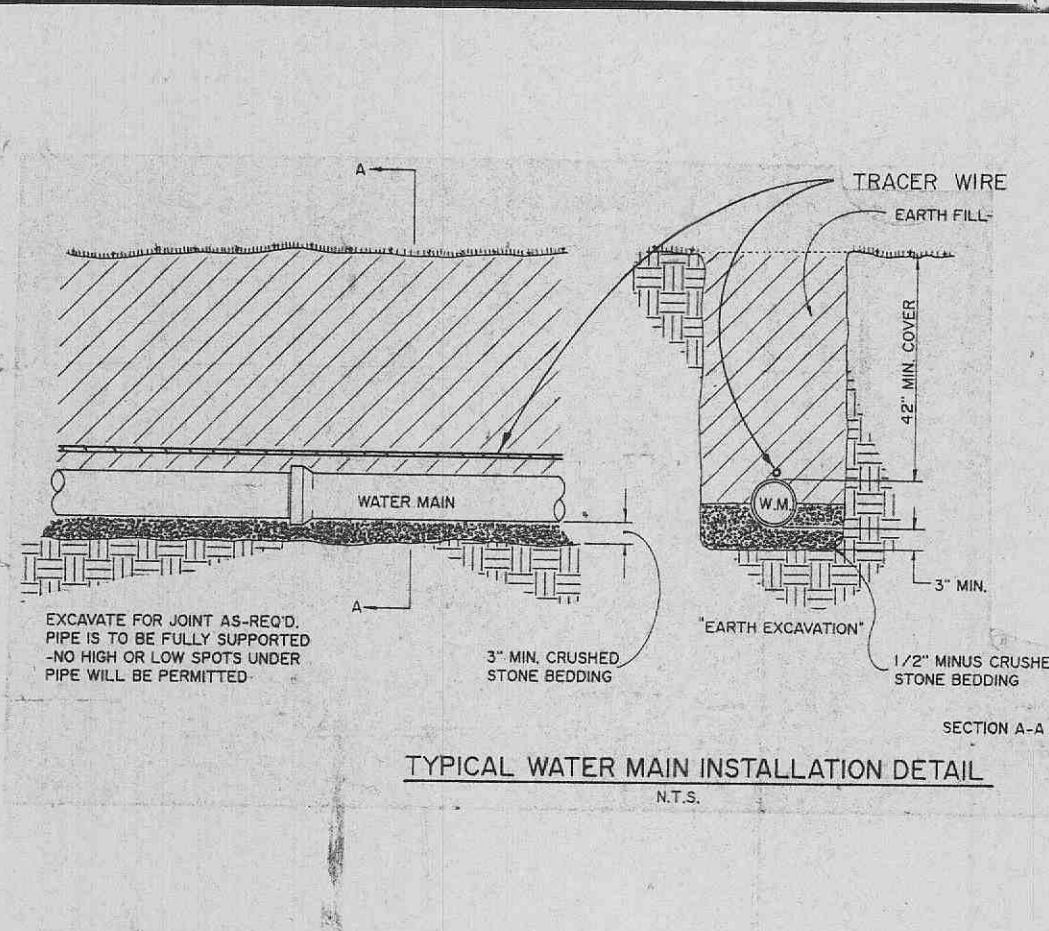
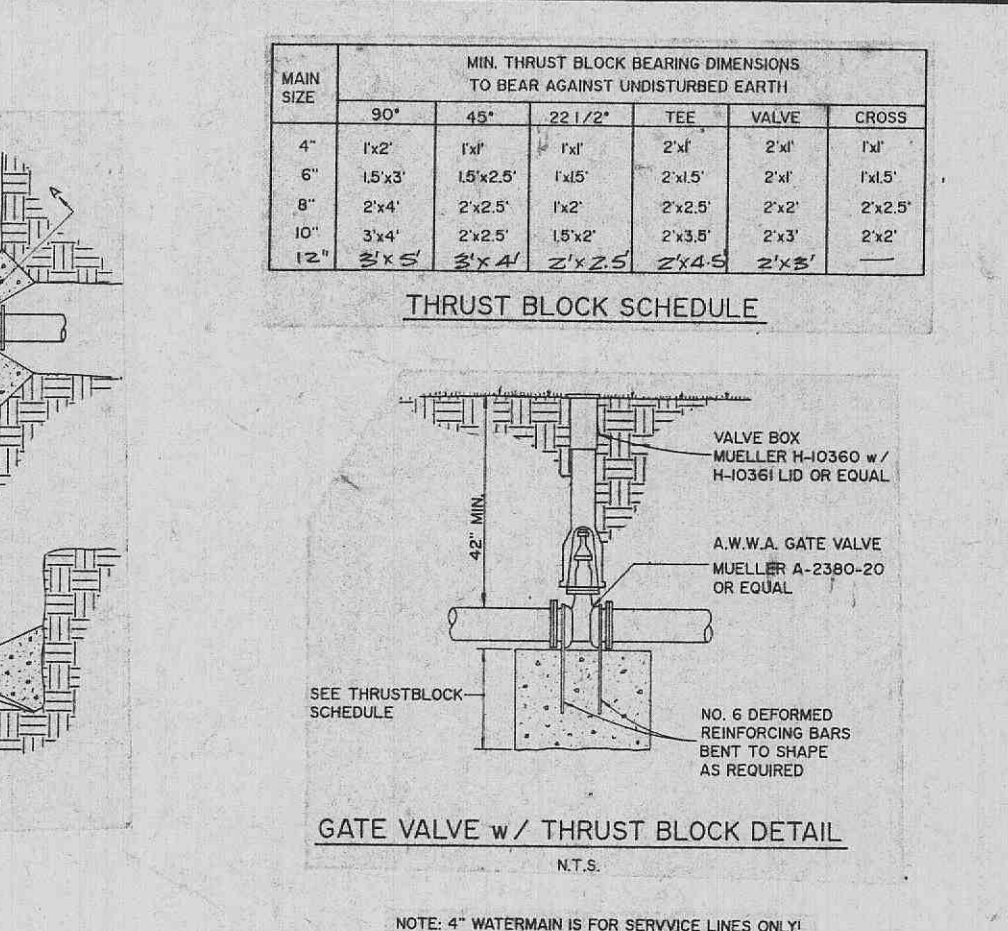
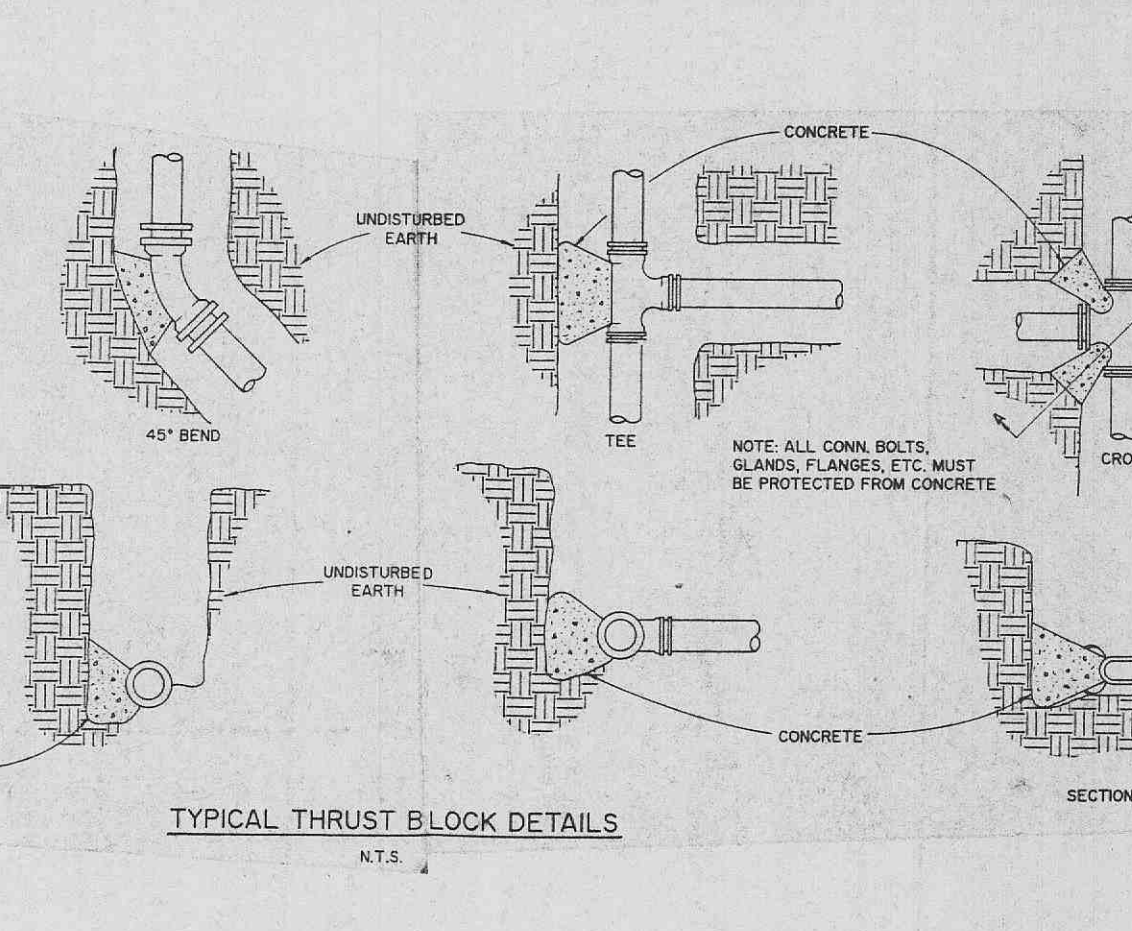
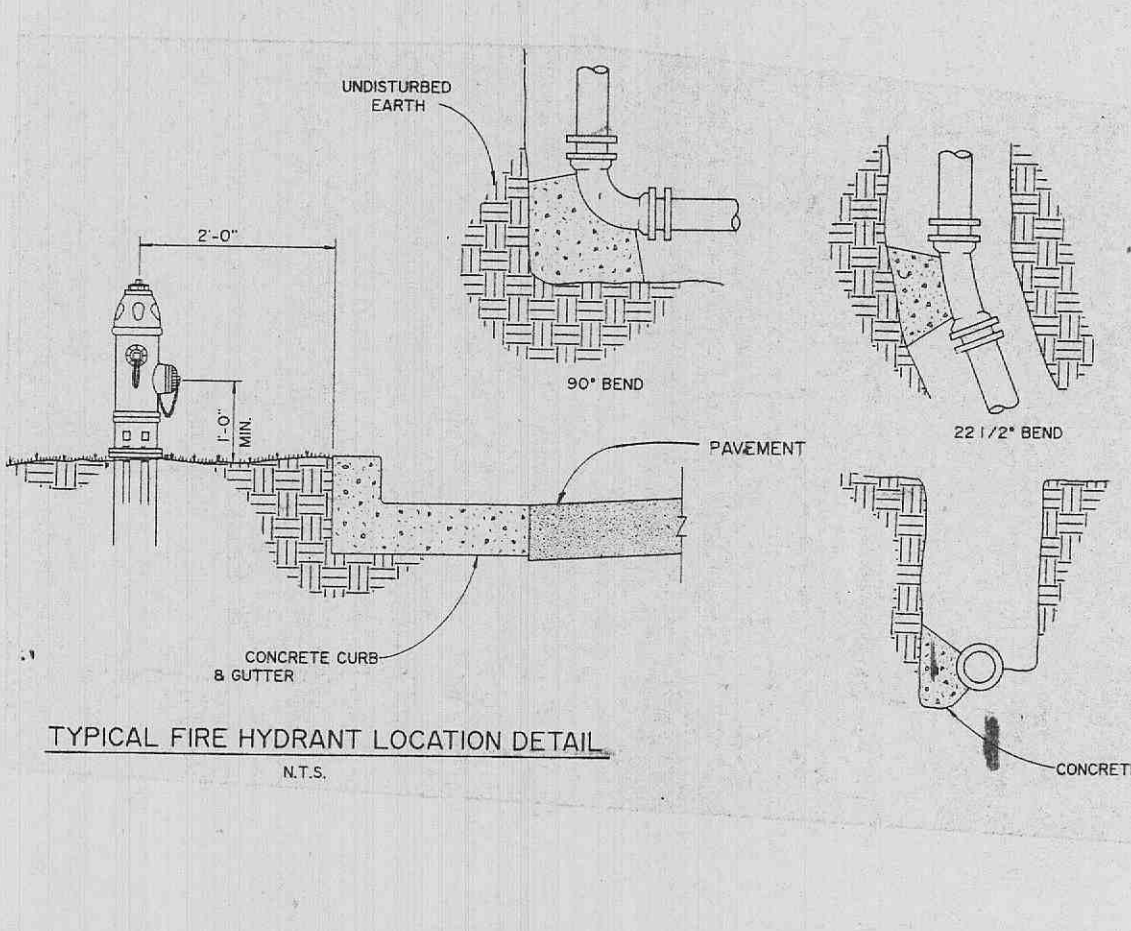
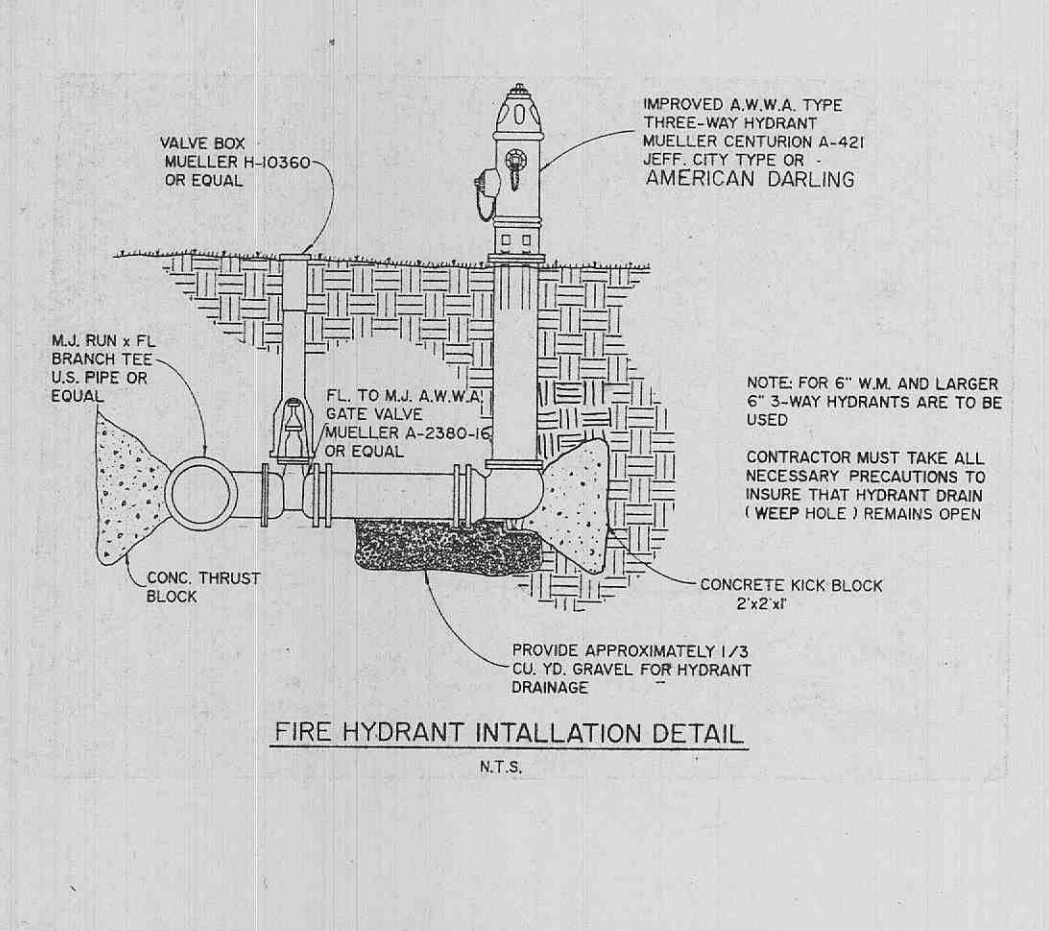
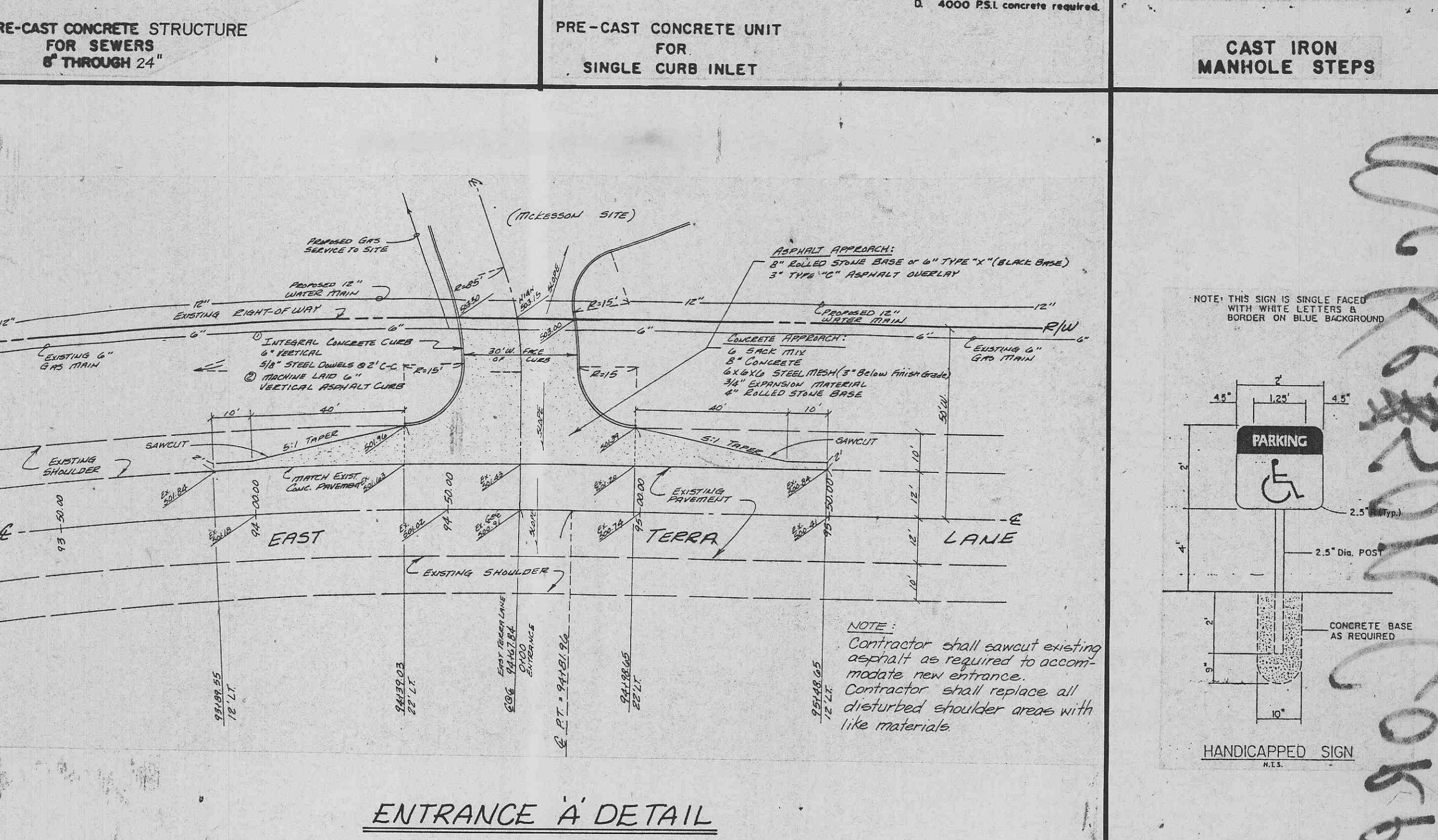
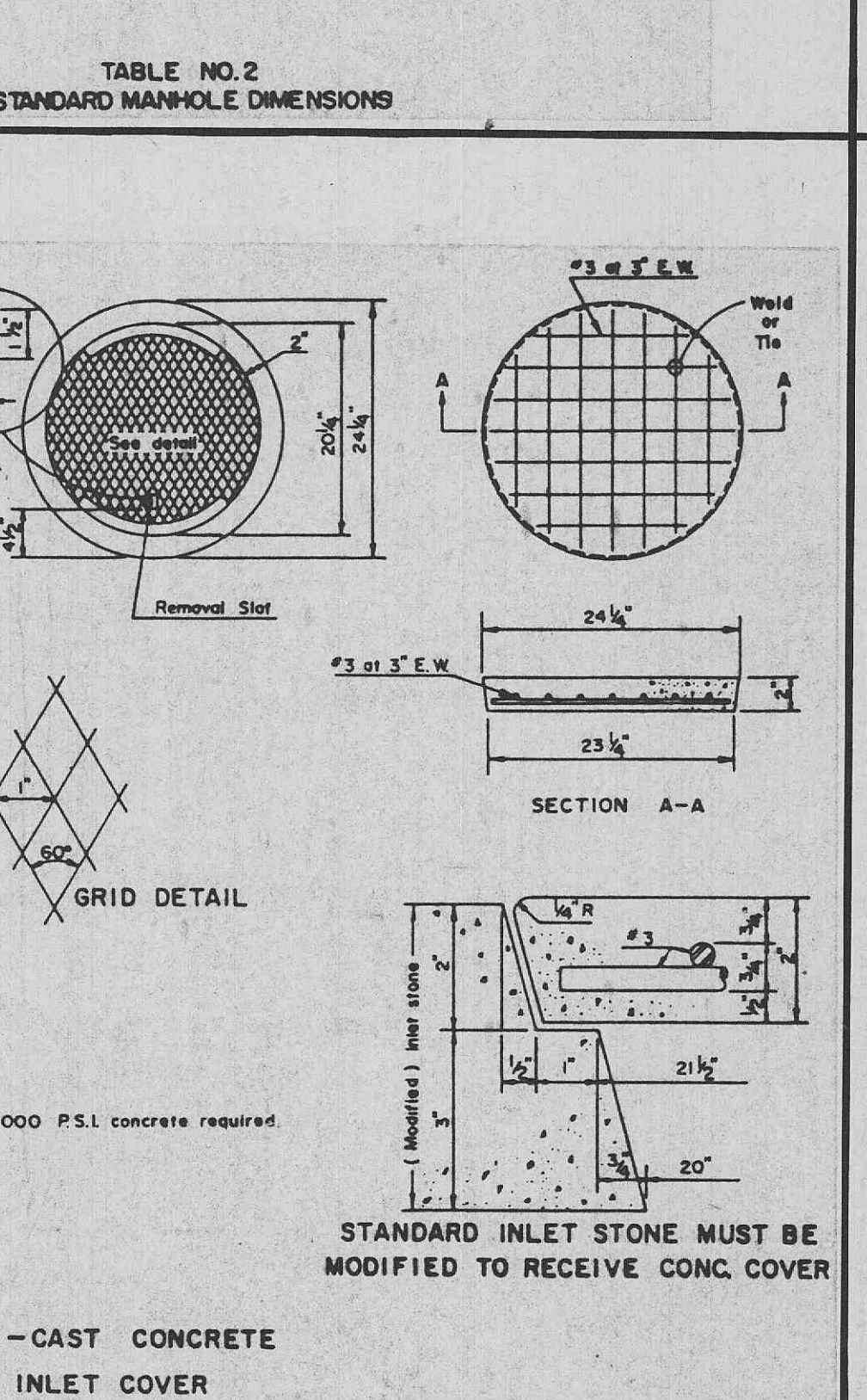
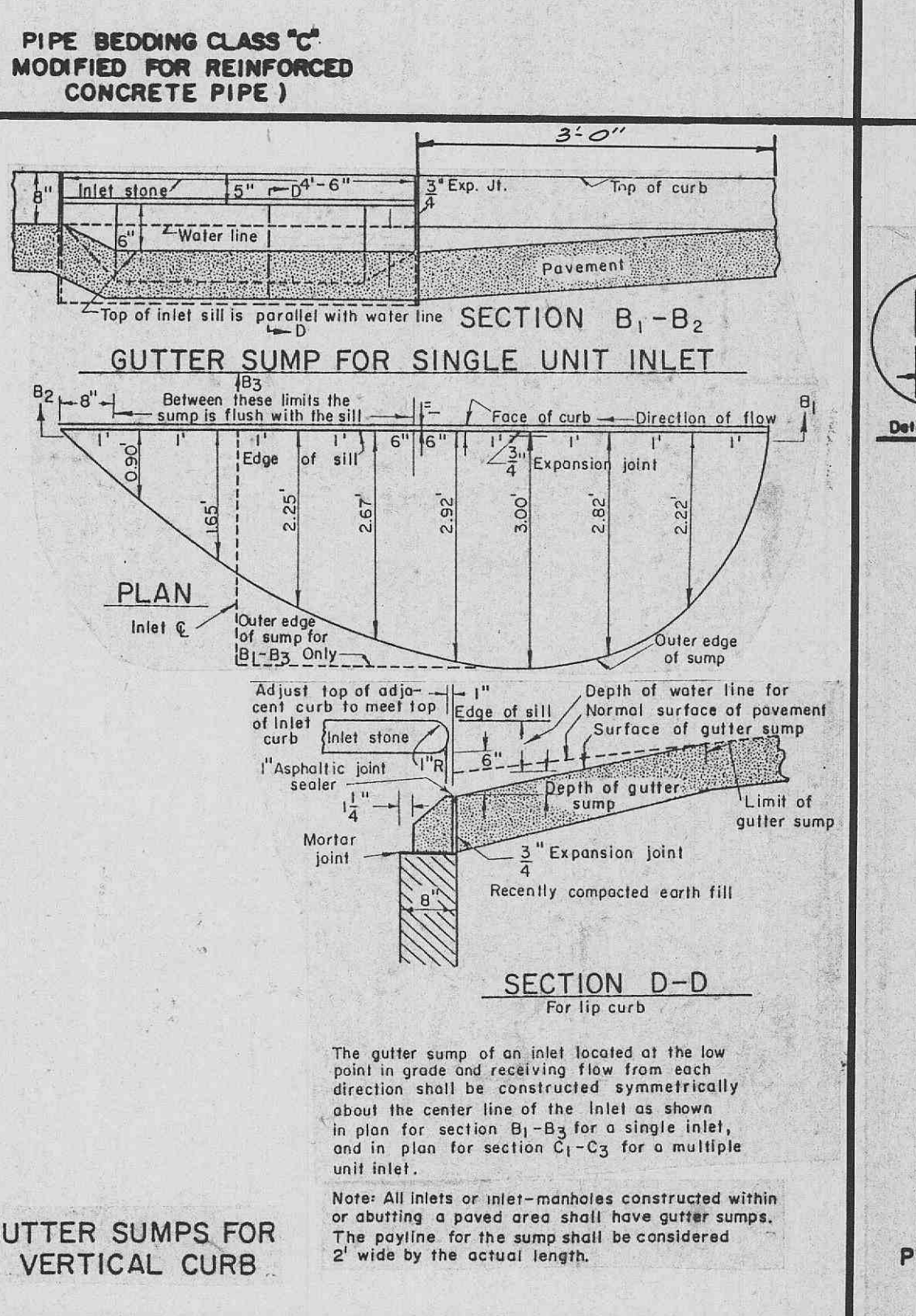
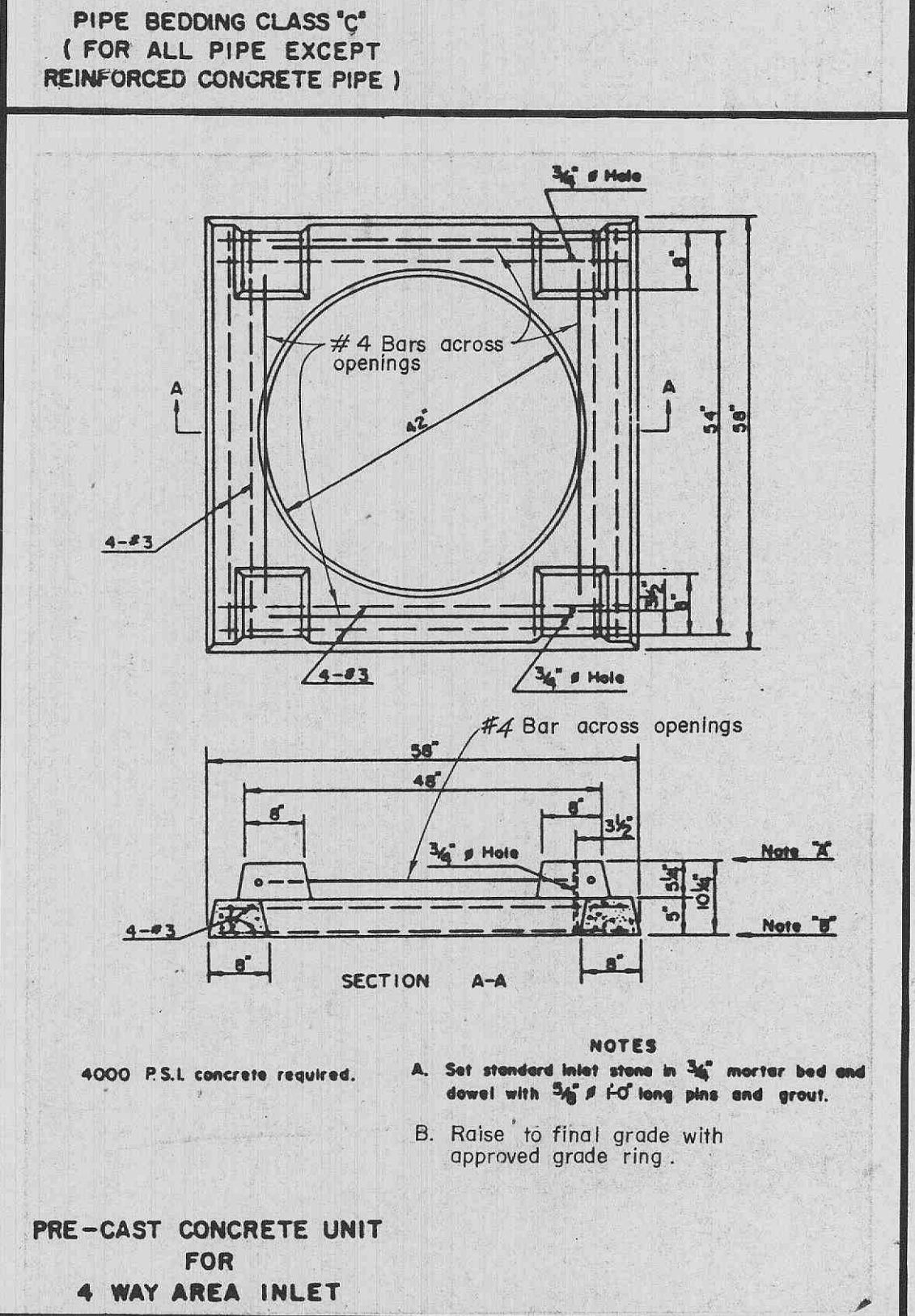
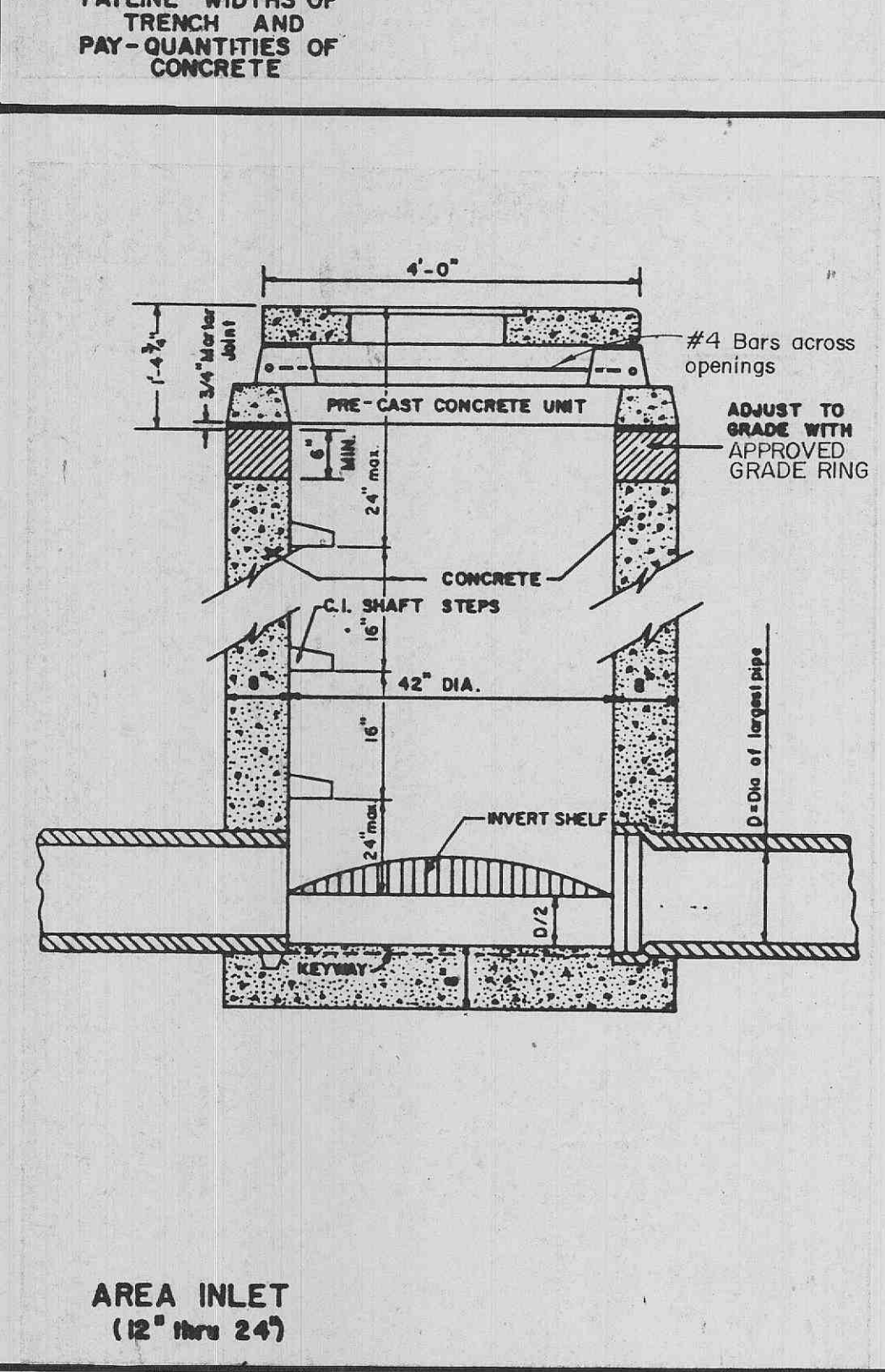
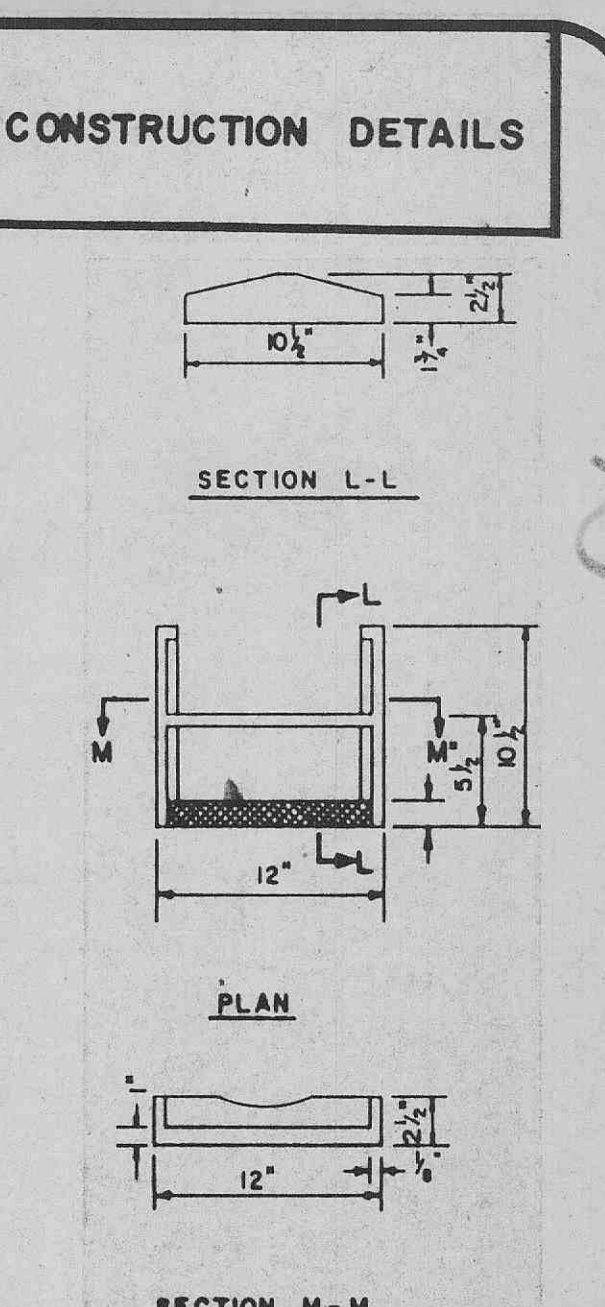
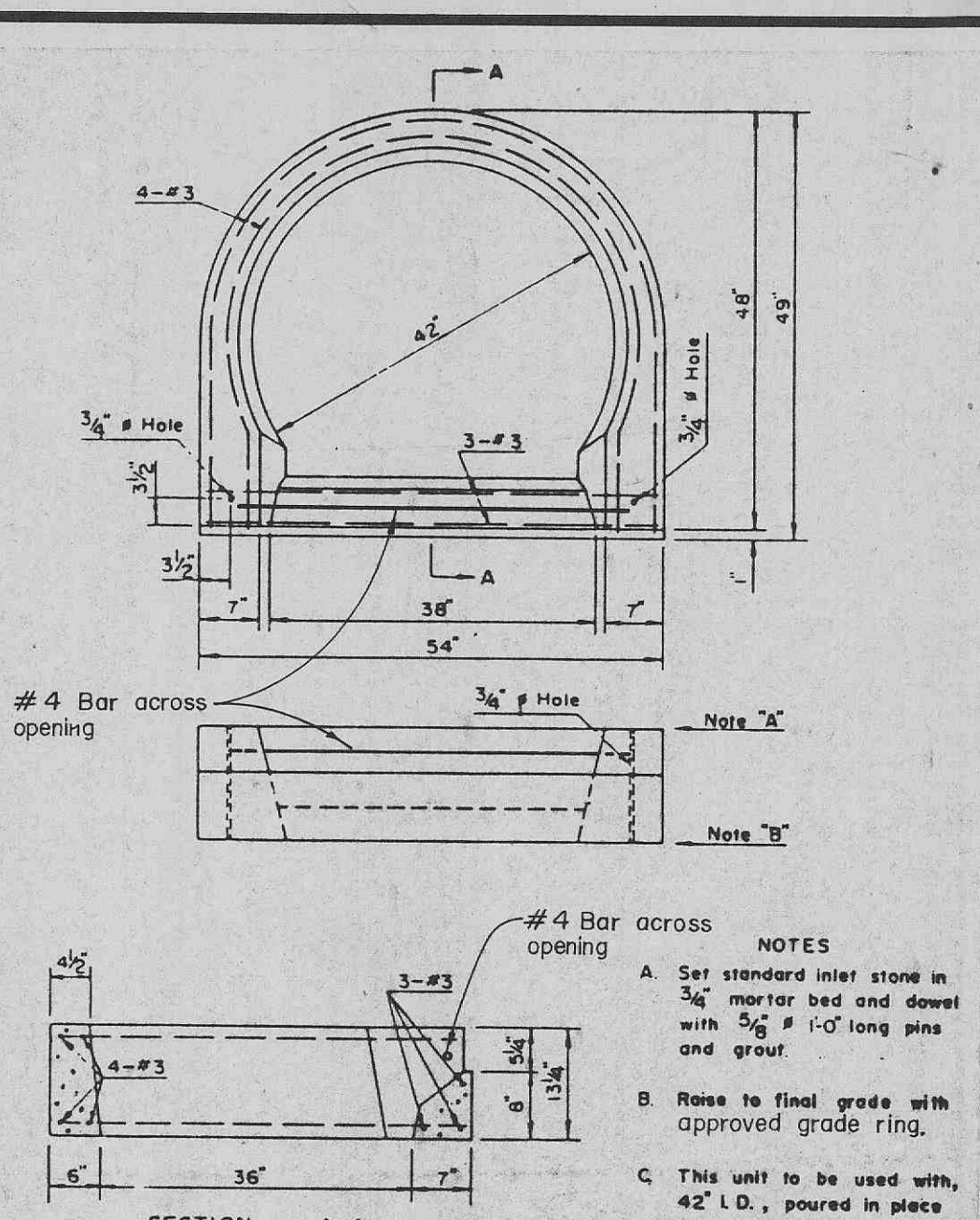
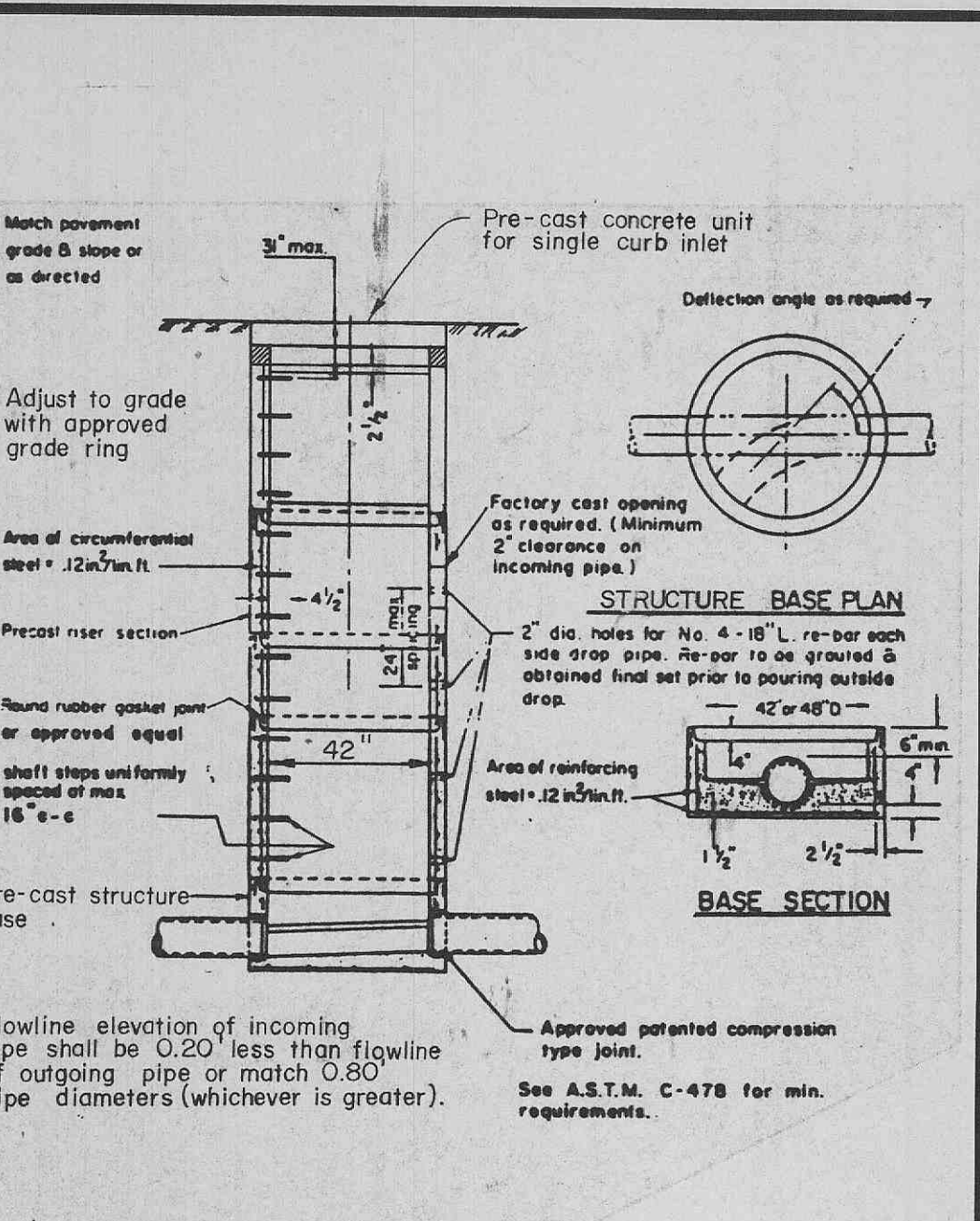

TABLE NO. 2
STANDARD MANHOLE DIMENSIONS

Section of Manhole	Dimension
Top	Upper 2'-6" Dia.
Transition	Lower 3'-6" Dia.
Bottom Section	6" thru 24" Dia. Pipe
Bottom Section	27" thru 36" Dia. Pipe
Bottom Section	3'-6" Square



PREPARED BY: PICKETT RAY & SILVER
Civil Engineers
Planning
Land Surveyors

NEW DISTRIBUTION FACILITY
OWNER: McKesson Corporation
CONTRACTOR: R. W. Murray Co

Revision Dates
Issue Date
Sheet Title
RWM Job Number
571
Sheet Number
C-5

3/14/90
3/6/90