

Payline Width of Trench (Inches)	Payline Width of Trench (Feet)	Payline Width of Trench (Inches)	Payline Width of Trench (Feet)	Payline Width of Trench (Inches)	Payline Width of Trench (Feet)	Payline Width of Trench (Inches)	Payline Width of Trench (Feet)
4	28	233	3.20				
8	28	233	3.46				
10	28	233	3.70				
12	28	233	3.98				
15	32	267	4.89				
18	35	292	5.63	14 x 23	41	3.42	5.94
21	39	325	6.61				
24	42	350	7.39	19 x 30	49	4.08	7.66
27	45	375	8.18	22 x 34	53	4.42	8.61
30	49	408	9.30	24 x 38	58	4.83	9.70
33	53	442	10.33	27 x 42	62	5.17	10.71
36	56	467	11.43	29 x 45	66	5.50	11.72
39	DISCONTINUED						
42	63	525	13.38	34 x 53	75	6.25	14.05
48	70	583	15.67	38 x 60	83	6.92	16.18
54	77	642	18.15	43 x 68	92	7.67	18.81
60	84	700	20.73	48 x 76	101	8.42	21.58
66	91	758	23.45	53 x 83	109	9.08	24.30
72	98	817	26.37	58 x 91	118	9.83	27.45
78	105	875	29.39	63 x 98	126	10.50	30.50
84	112	933	32.57	68 x 106	135	11.25	33.91
90	119	992	35.90	72 x 113	143	11.92	36.99
96	126	1050	39.37	77 x 121	152	12.67	40.88
102	133	1108	42.99	82 x 128	160	13.33	44.46
108	140	1167	46.75	87 x 136	168	14.00	47.79
114	147	1225	50.66	92 x 143	176	14.67	51.70
120	154	1283	54.72	97 x 151	185	15.42	56.01
126	161	1342	58.92				
132	168	1400	63.27	106 x 166	202	16.83	64.48
144	182	1517	72.40	116 x 180	218	18.17	73.58

TABLE NO. 1
 PAYLINE WIDTHS OF TRENCH AND PAY - QUANTITIES OF CONCRETE

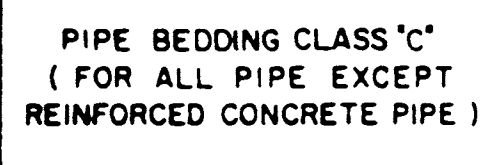

DETAIL 1

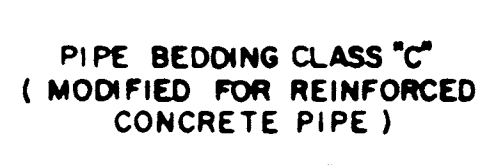

DETAIL 2

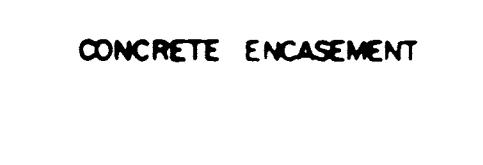

DETAIL 3



DETAIL 4

Section of Manhole	Dimension
Top	Upper 2'-2 1/2" Dia.
Transition	Lower 3'-6" Dia.
Bottom Section	8" thru 24" Dia. Pipe 3'-6" Dia.
Bottom Section	27" thru 36" Dia. Pipe 3'-6" Square

TABLE NO. 2
 STANDARD MANHOLE DIMENSIONS

DETAIL 5

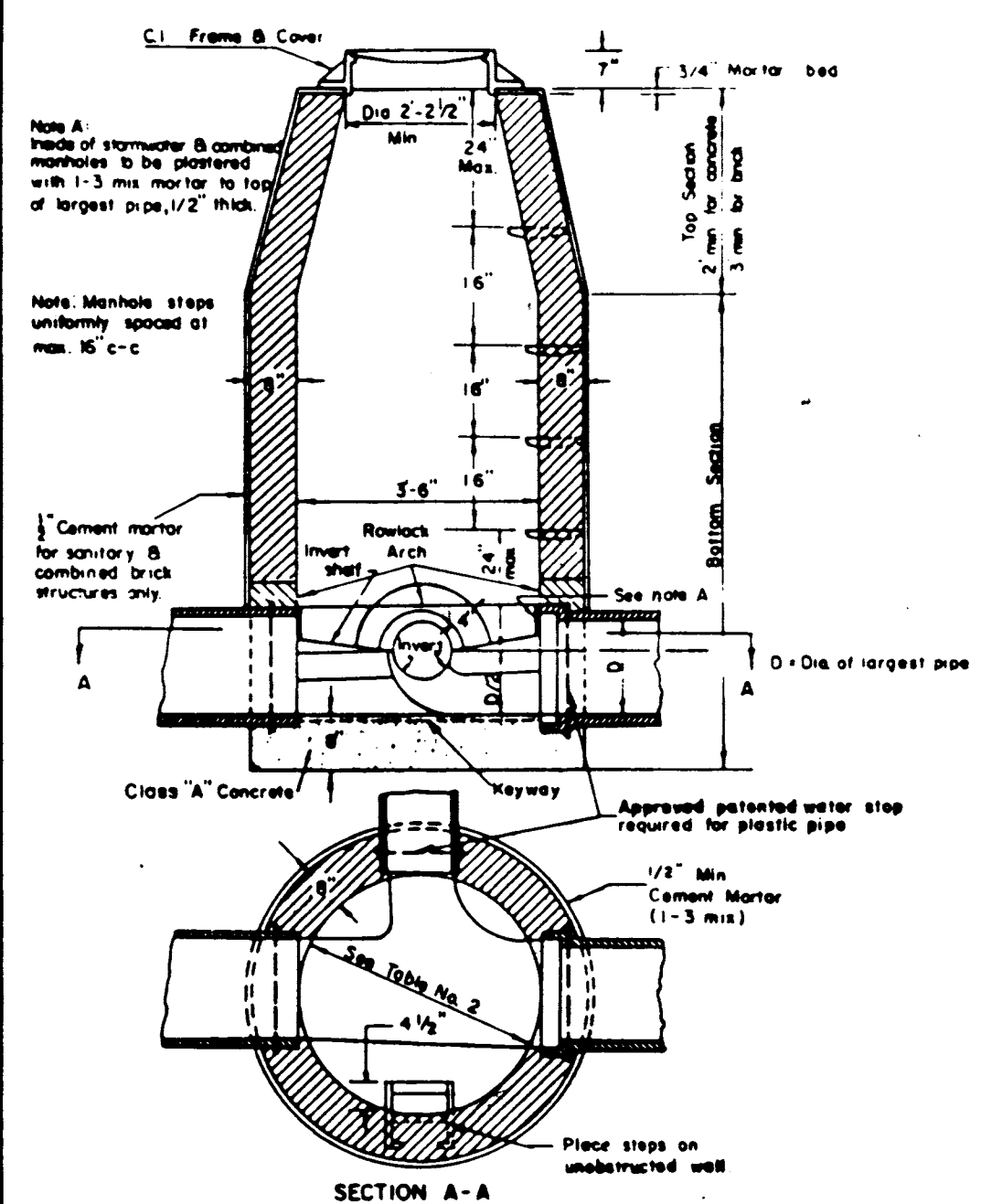

DETAIL 7

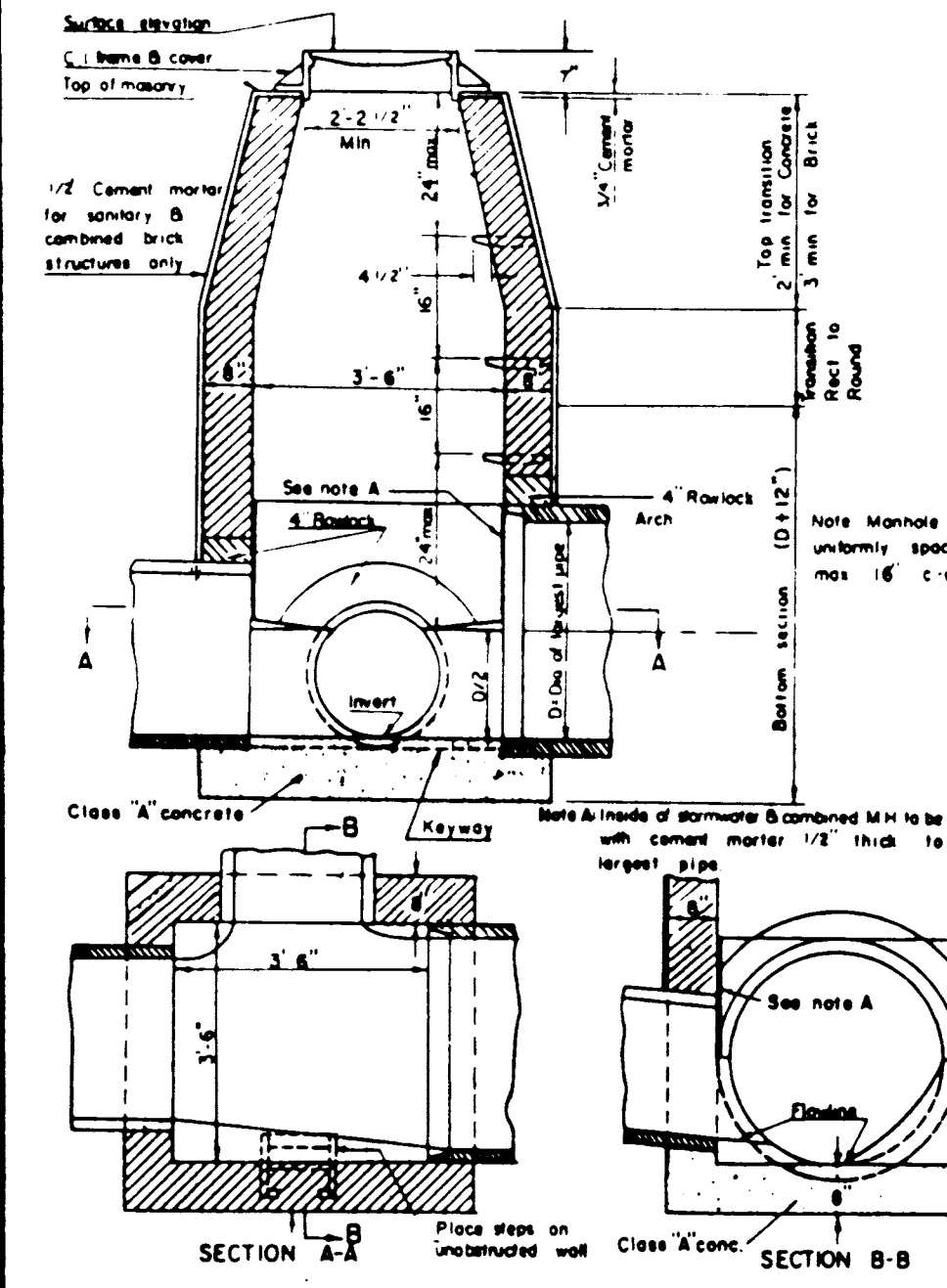

DETAIL 8

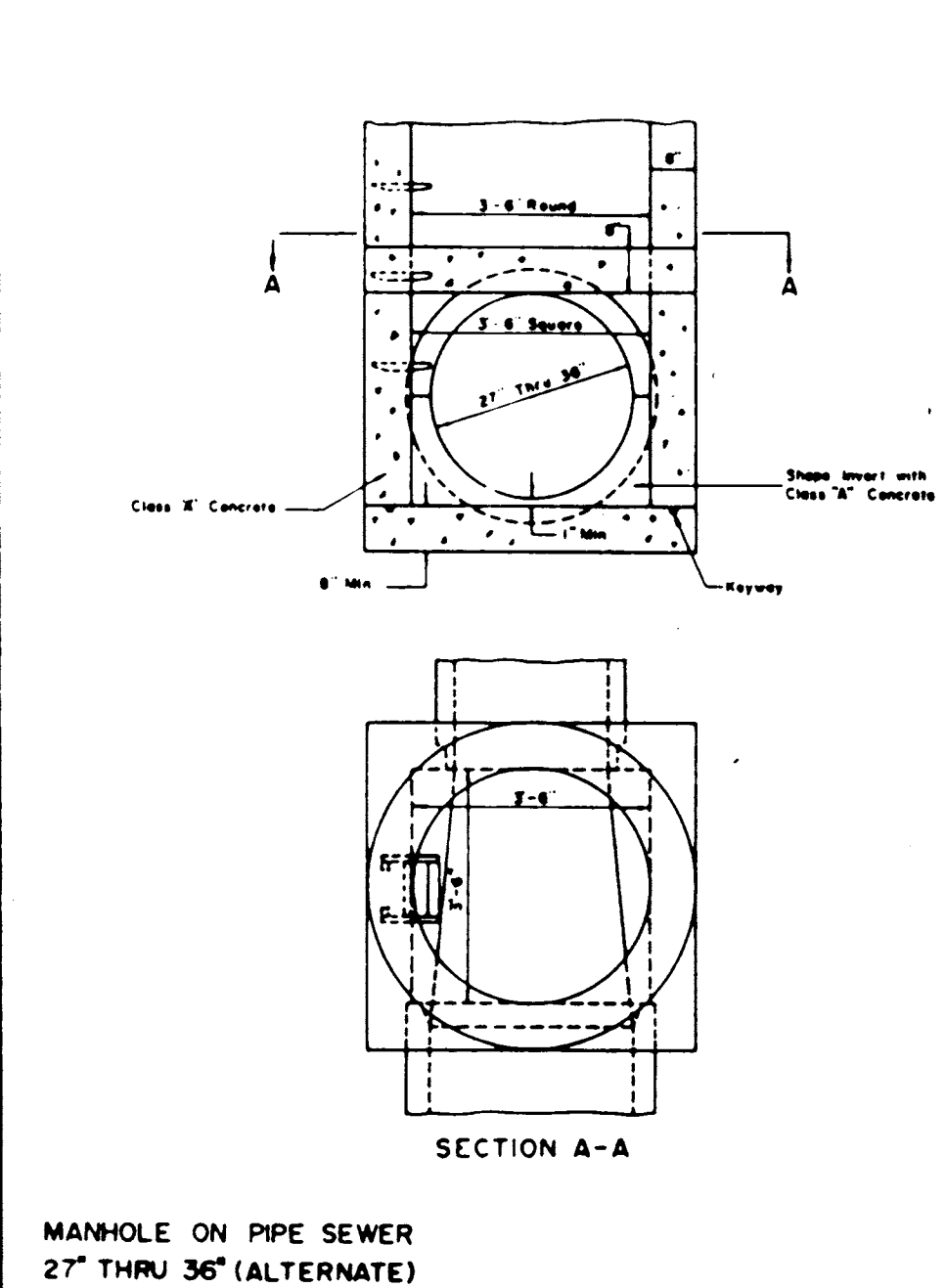

DETAIL 9

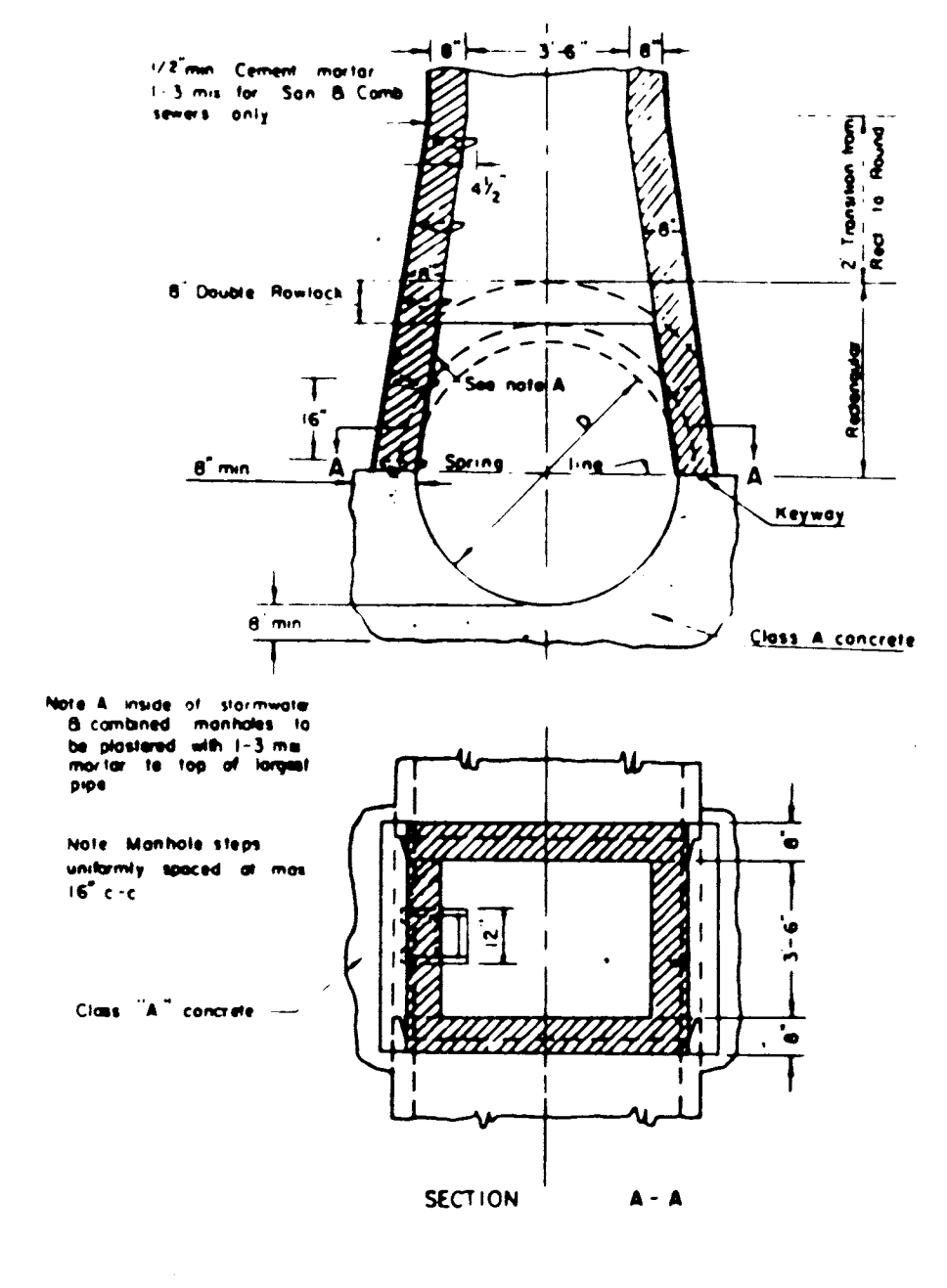

DETAIL 10

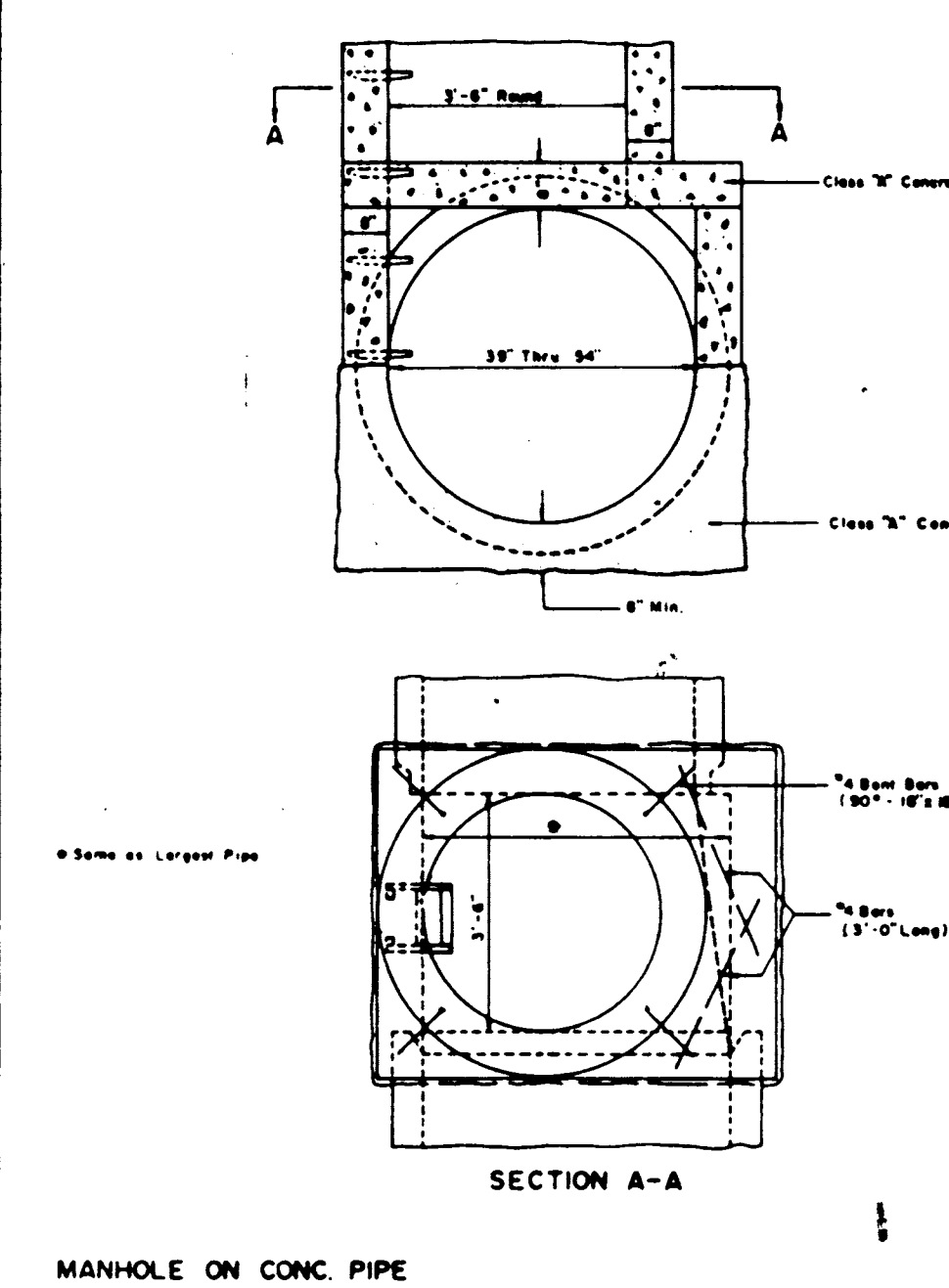

DETAIL 11

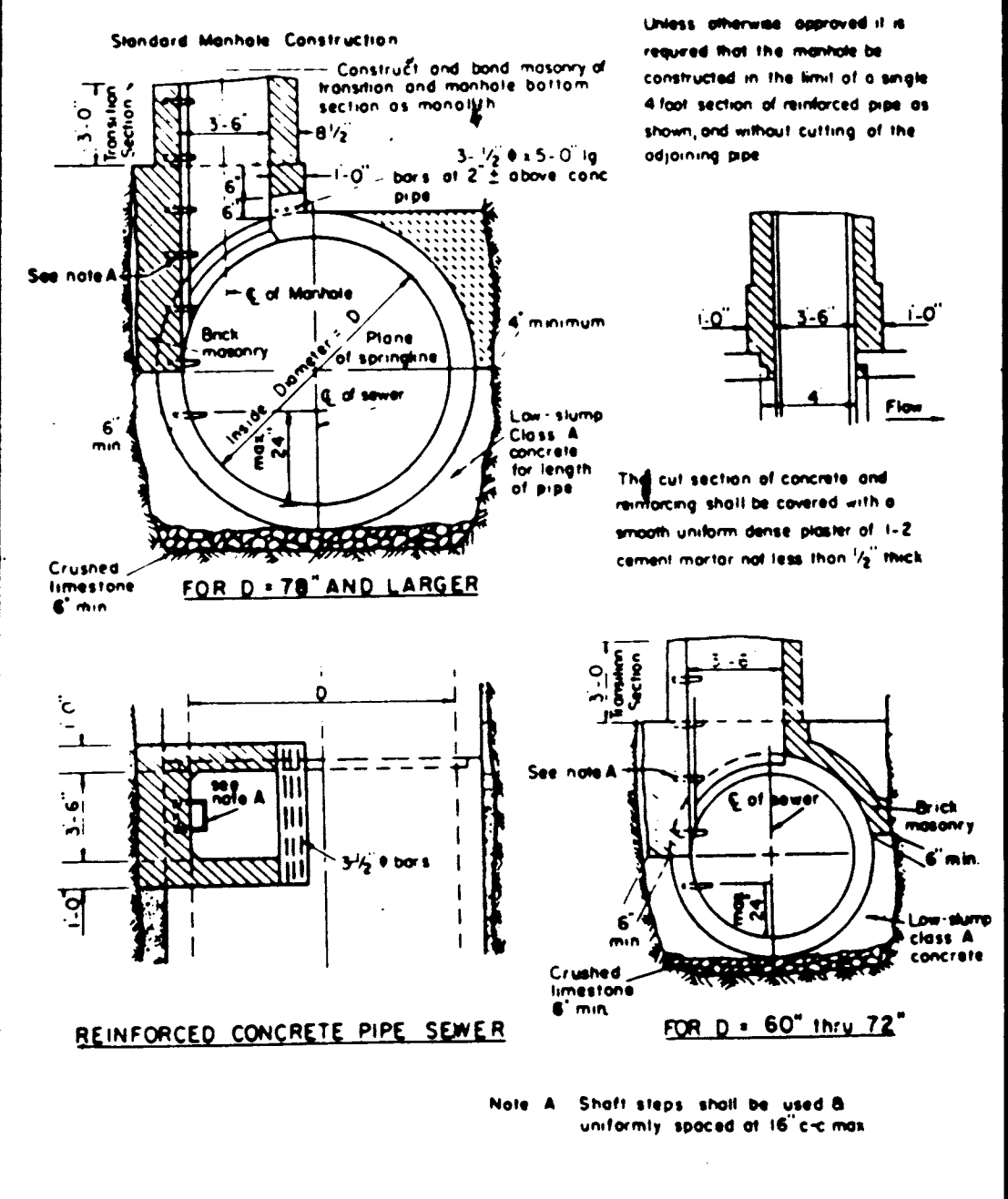

DETAIL 12

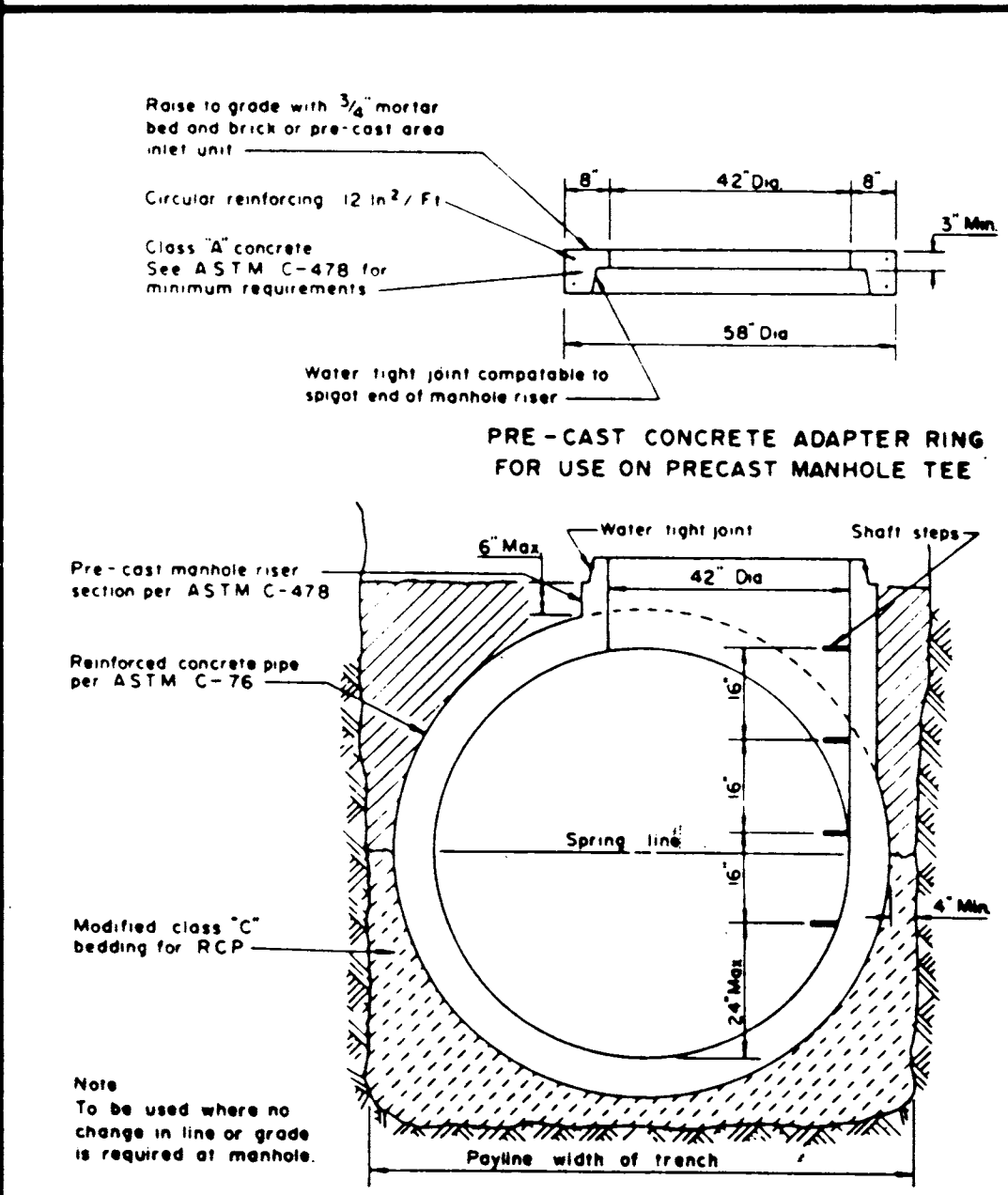

DETAIL 13

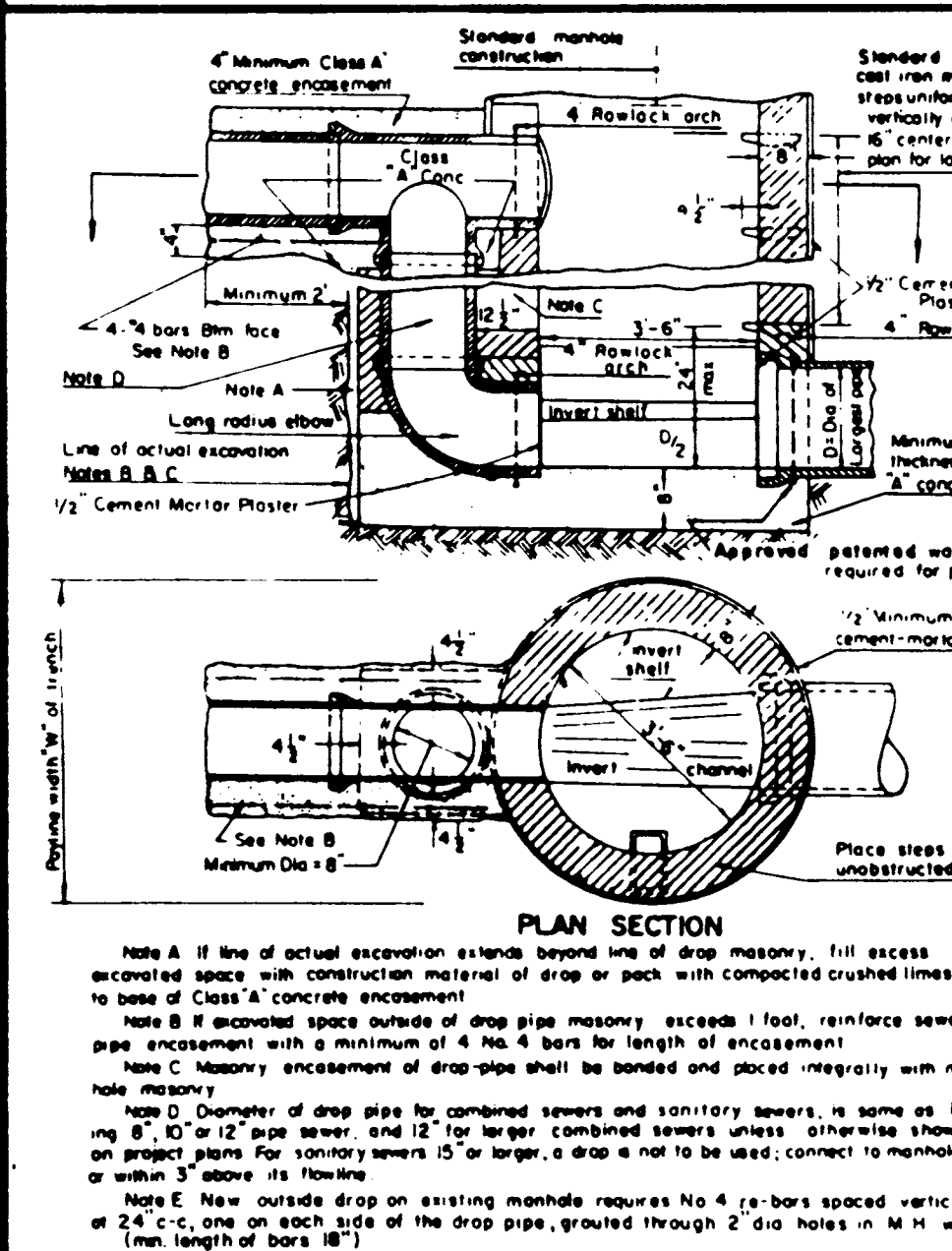

DETAIL 14

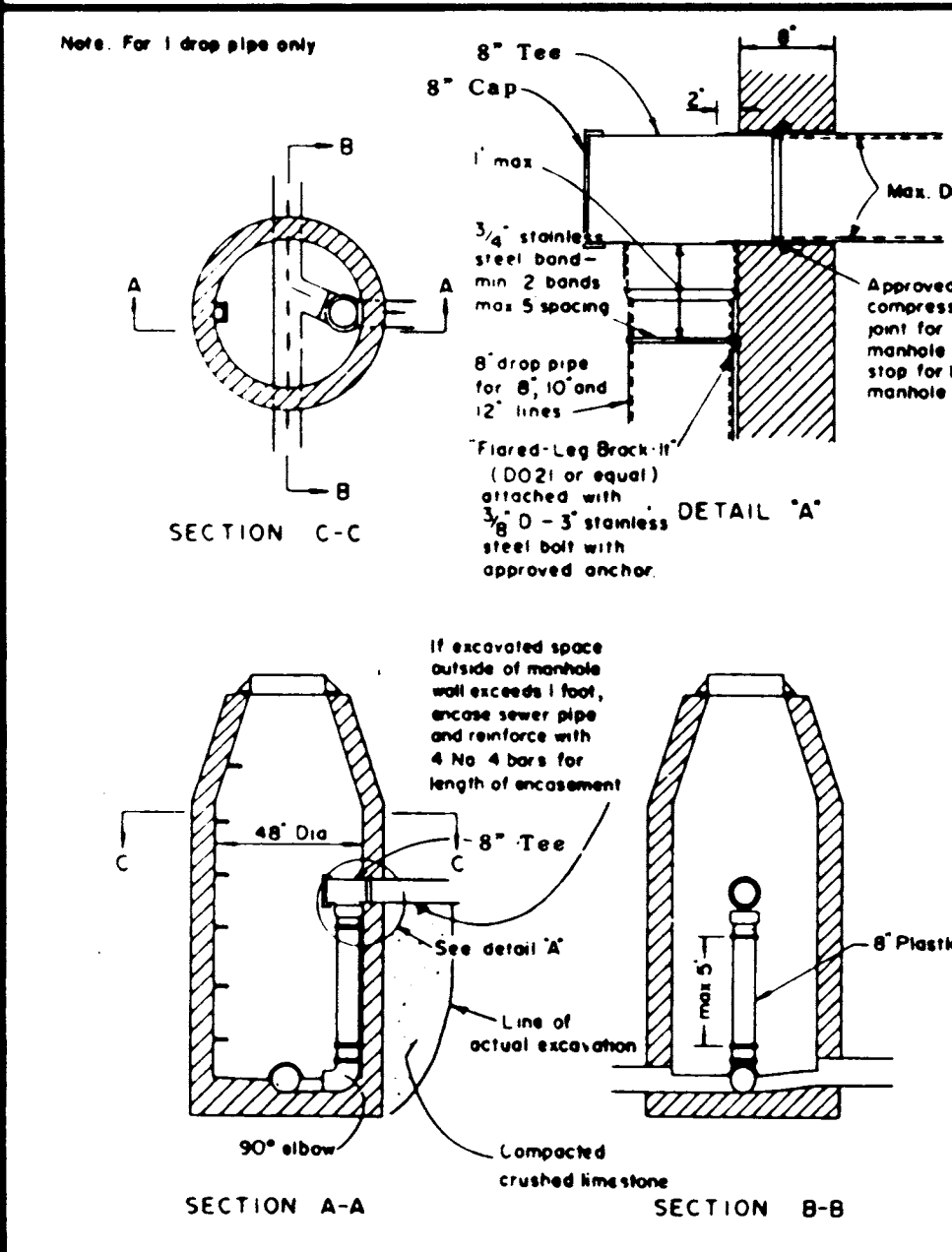

DETAIL 15

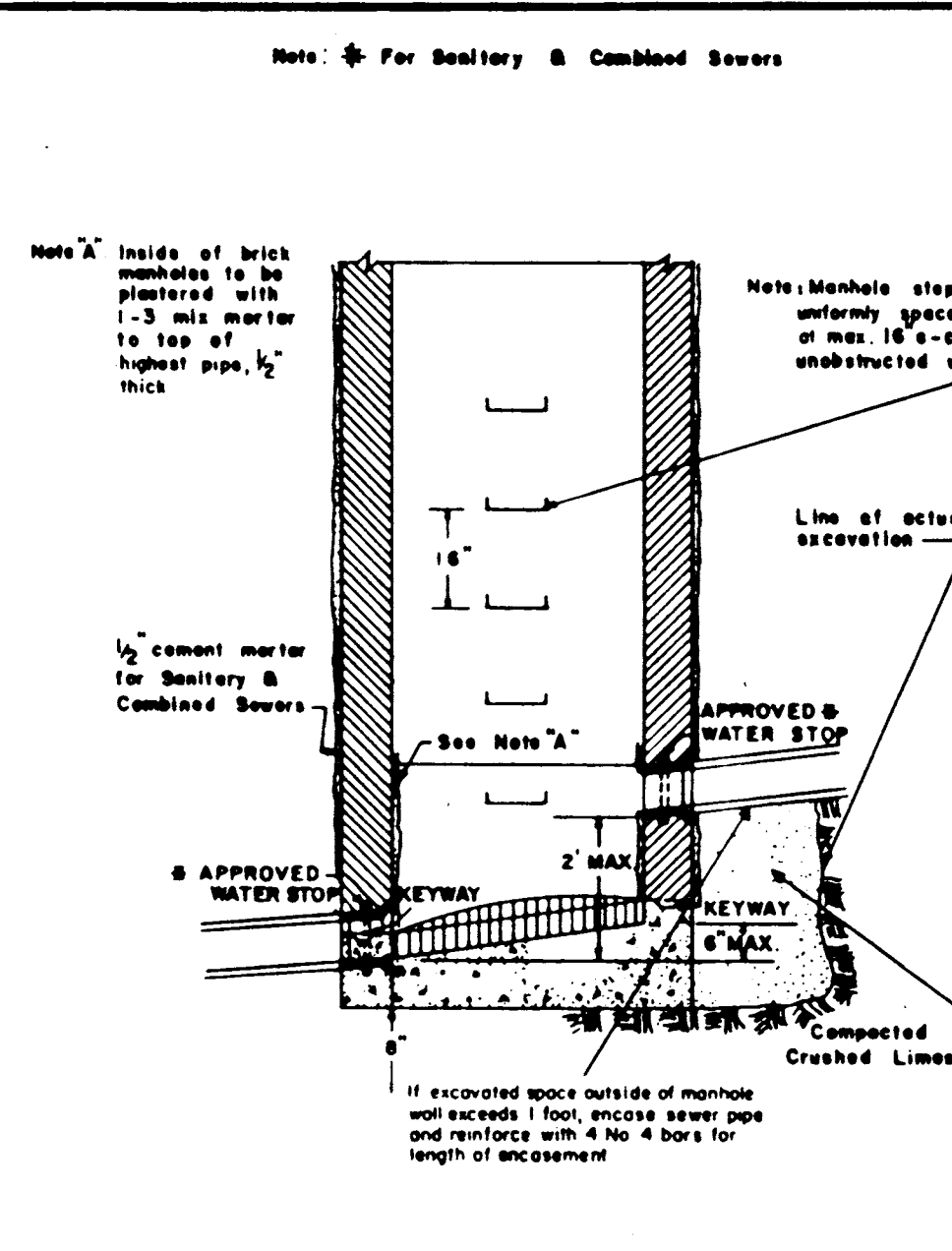

DETAIL 16

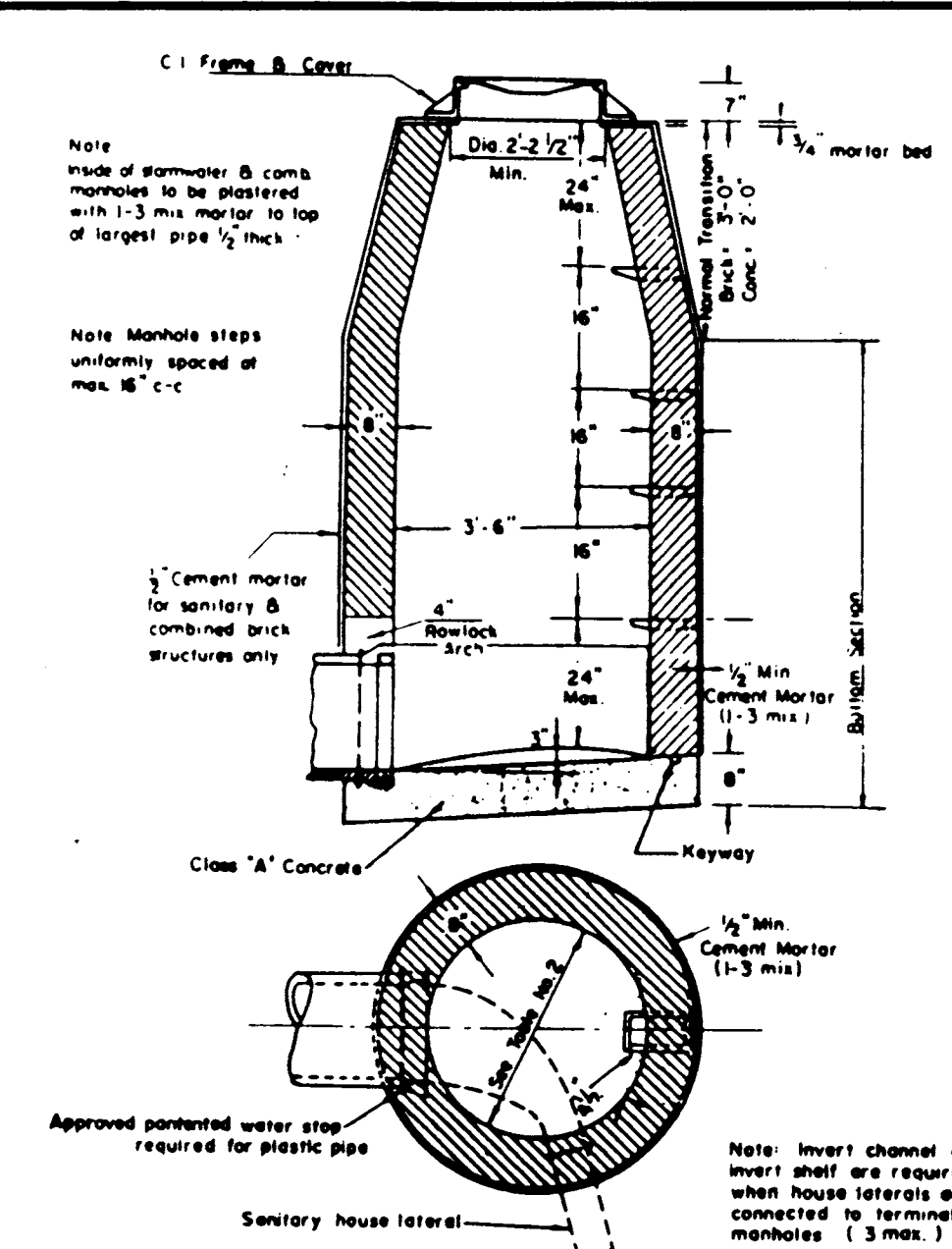

DETAIL 17

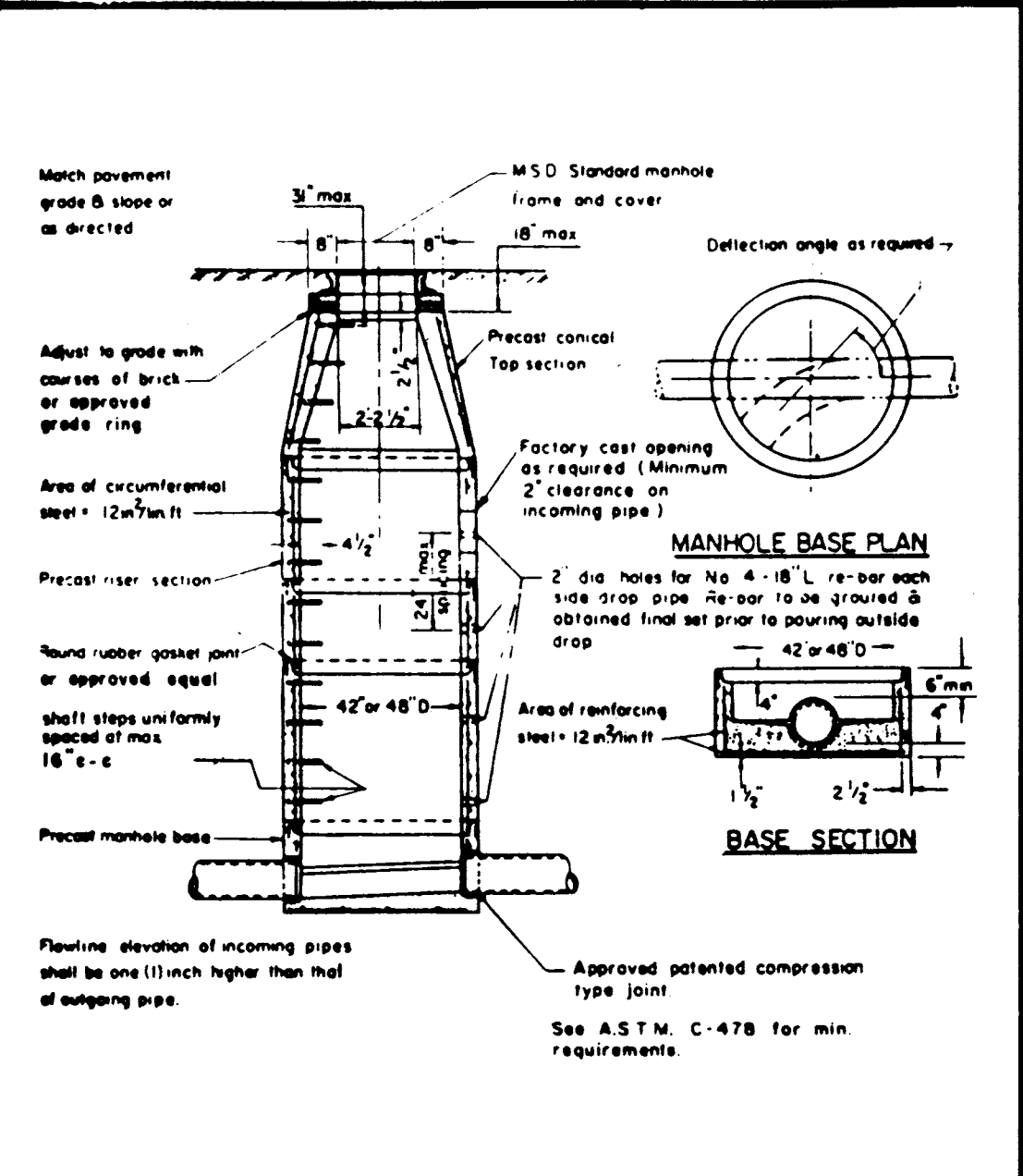

DETAIL 18