

NOTES:
 (1) CROSS SLOPE SHALL BE SUFFICIENT TO PREVENT POOLING UP TO A MAXIMUM OF 1/8" PER FOOT.
 (2) THE FINISH GRADE OF A BLENDED TRANSITION MAY BE WAVED TO MEET ROAD GRADE UP TO 5% MAXIMUM.
 (3) BLENDING DISTANCE BETWEEN PAVEMENT ON EITHER SIDE OF THE DIRECTION OF TRAVEL AND CURB RAMP SHALL NOT EXCEED 15' FROM THE POINT OF INTERSECTION.
 (4) CROSS SLOPE SHALL BE A MIN OF 1/8" AND A MAX OF 2% AT INTERSECTIONS WITH SIDE OR YIELD LANE OR A CROSS DIFFERENT EXISTING SLOPE INTERSECTIONS WITHOUT STOP ON YIELD CONTROL.
 (5) CURB RAMP FINISH SLOPE SHALL BE 5% MAX.
 (6) TRANSVERSABLE FLARE FINISH SLOPE SHALL BE 5% MAX.
 (7) IN ORDER TO PREVENT HAZARDOUS SLOPE CHANGES AND NON-TRANSVERSABLE FINISH MAY BE USED WHEN NECESSARY. A MINIMUM OF 18" OF 1/2" DIA. VERTICAL CURB ADJACENT TO THE PAVEMENT ACCESS SHOULD BE MAINTAINED.
 GENERAL NOTES:
 THE CONTRACTOR SHALL COMPLY WITH ALL LAWS PERTAINING TO THE MATERIALS AND METHODS TO BE USED ON PUBLIC RIGHTS-OF-WAY. ALL EXISTING UTILITIES SHALL BE REMOVED AND RECONNECTED AT THE CONTRACTOR'S EXPENSE.
 SIDEWALK AND RAMP WITH SHALL BE 8" MIN FOR ANIMAL WASTE COLLECTION. CURB AND RAMP SHALL NOT BE FINISHED FOR THE CONSTRUCTION OF SIDEWALKS.
 SIDEWALK SHALL BE STABLE, SLIP RESISTANT, AND SURFACE SHALL MAINTAIN THE GRADE OF AN ADJACENT ROADWAY.
 A DIAGONAL RAMP IS A SINGLE CURB RAMP WHICH SERVES TWO CROSSINGS. DIAGONAL RAMP SHALL NOT BE FINISHED FOR THE CONSTRUCTION OF SIDEWALKS.
 LANEWAYS, TRUNK SPACES, AND CLEAR SPACES LOCATED IN THE ROADWAY MUST BE COMPLETELY CONTAINED WITHIN THE CROSSING.
 TRANSITIONS FROM SIDEWALK TO GUTTER TO ROADWAY MUST BE FLUSH.
 DETECTABLE WARNING DEVICES ARE REQUIRED AT PUBLIC STREETS AND GATED ENTRANCES TO DETECTABLE WARNING. SEE REQUIREMENTS SET STANDARD DRAWING C608.41.
 FINISH GRADE OF CURVED SIDEWALKS AND RAMP SHALL BE MEASURED ON THE INSIDE EDGE OF THE CURVE.
 10 FOOT MINIMUM FINISH SLOPE FOR A CURB RAMP IS NOT INTEND TO BLIND WARRIOR IF THE CONSTRUCTION CURB RAMP EXCEEDS 10 FEET IN LENGTH THIS EXCEPT FOR SIDEWALK RAMP.
 CROSS BREAK BETWEEN RAMP AND ADJACENT SIDEWALK MUST BE PERPENDICULAR TO THE DIRECTION OF TRAVEL.
 TYPE A CURB IS INCIDENTAL TO CURB RAMP CONSTRUCTION. NO ADDITIONAL FINISH SHALL BE PROVIDED.
 A CLEAR SPACE SHALL BE PROVIDED BEYOND THE BOTTOM GRADE BREAK OF A CURB. THE CLEAR SPACE SHALL BE THE NUMBER OF FEET OF 1/4 FT AND REUSE WHOLLY OUTSIDE OF THE PARALLEL VEHICLE TRAVEL LANE.
 A 6" BY 6" SQUARE FINISH SPACE SHALL BE PROVIDED IN THE CENTER OF CURB. THIS SPACE SHALL BE 6" FROM THE CURB AND 6" FROM THE CENTER OF PARALLEL VEHICLE TRAVEL LANE.
 THE FINISH TRANSITION SHALL BE PROVIDED WHEN CONNECTING NEW PAVEMENT FACILITIES TO AN EXISTING ROADWAY.
 ALL RAMP AND GRADES SHALL BE MEASURED WITH A CALIBRATED 2 FOOT LONG RAMP.
 FINISH GRADE SHALL NOT BE PERMITTED FOR THE CONSTRUCTION OF CURB RAMP. FINISH GRADE SHALL BE MEASURED WITH A CALIBRATED 2 FOOT LONG RAMP.
 PAVEMENT INSTALLATIONS SHALL REQUIRE DEPARTMENTAL APPROVAL.

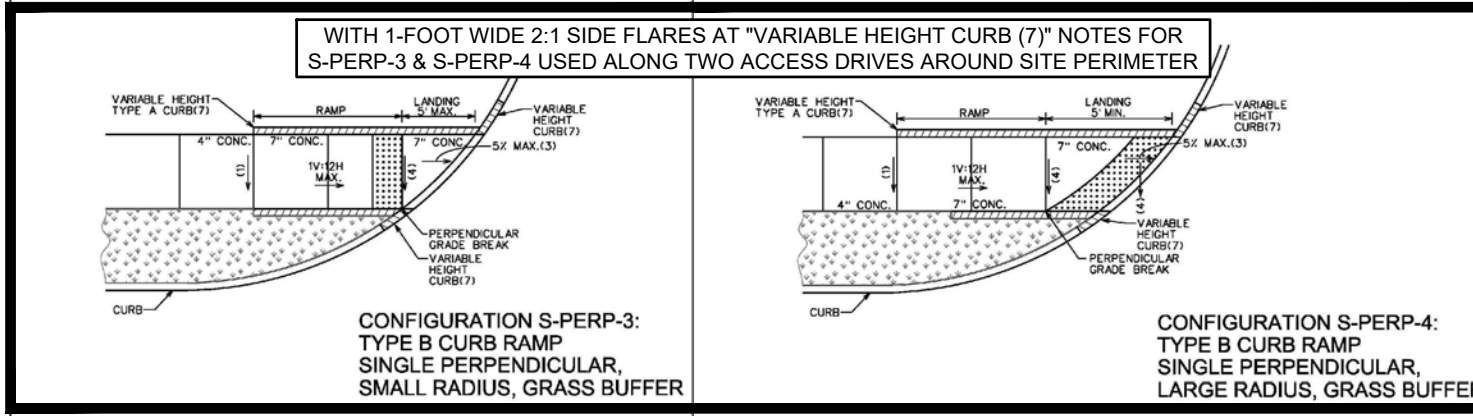

WITH 1-FOOT WIDE 2" SIDE FLARES AT VARIABLE HEIGHT CURB (7" NOTES FOR S-PERP-3 & S-PERP-4 USED ALONG TWO ACCESS DRIVES AROUND SITE PERIMETER)
 CONFIGURATION S-PERP-3: TYPE B CURB RAMP, SINGLE PERPENDICULAR, SMALL RADIUS, GRASS BUFFER
 CONFIGURATION S-PERP-4: TYPE B CURB RAMP, SINGLE PERPENDICULAR, LARGE RADIUS, GRASS BUFFER

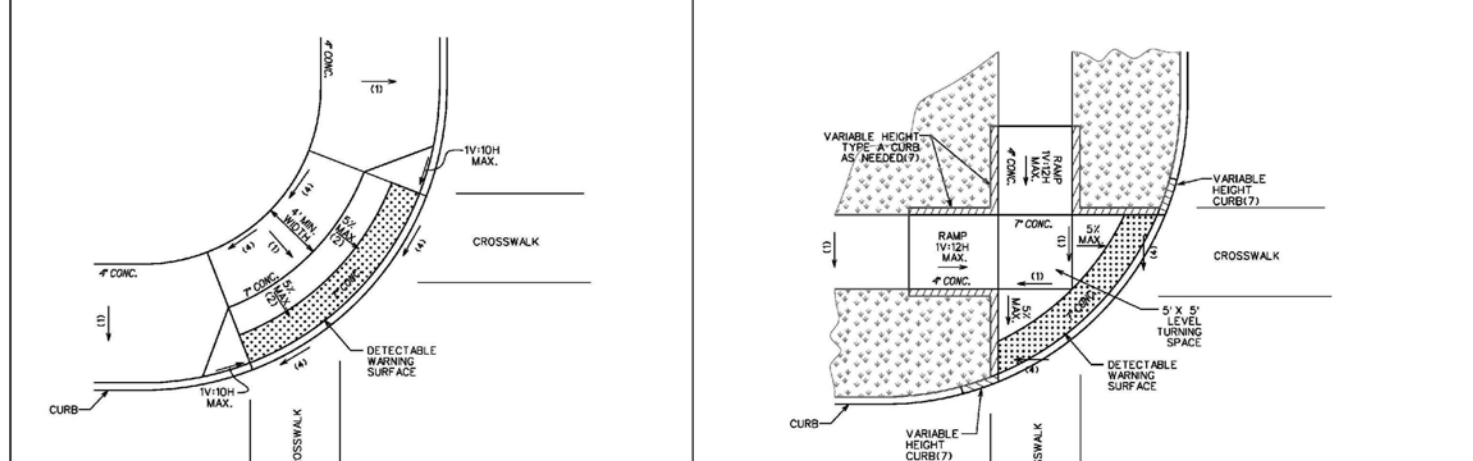

CONFIGURATION BT-1: TYPE E CURB RAMP, BLENDED TRANSITION, BACK OF CURB
 CONFIGURATION BT-COMB-1: TYPE E CURB RAMP, BLENDED TRANSITION, GRASS BUFFER

DATE: 03/06/2020	REVISIONS:	THIS IS NOT A CERTIFIED DOCUMENT	Seal of St. Louis COUNTY TRANSPORTATION	CURB RAMP CONFIGURATIONS FOR USE WITHIN PUBLIC RIGHT-OF-WAY	EFFECTIVE: 05/01/2020	SHEET: 1 OF 7	DRAWING: C608.41
------------------	------------	----------------------------------	---	---	-----------------------	---------------	------------------

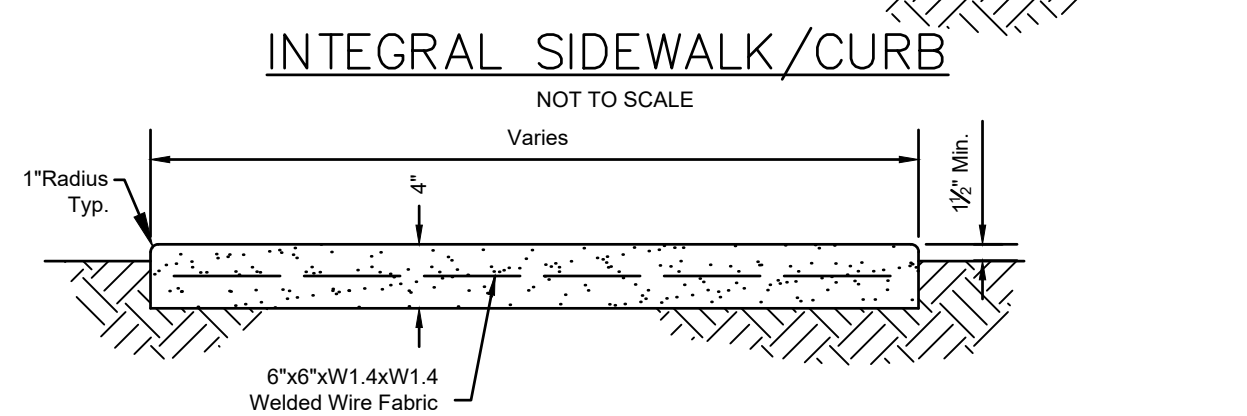
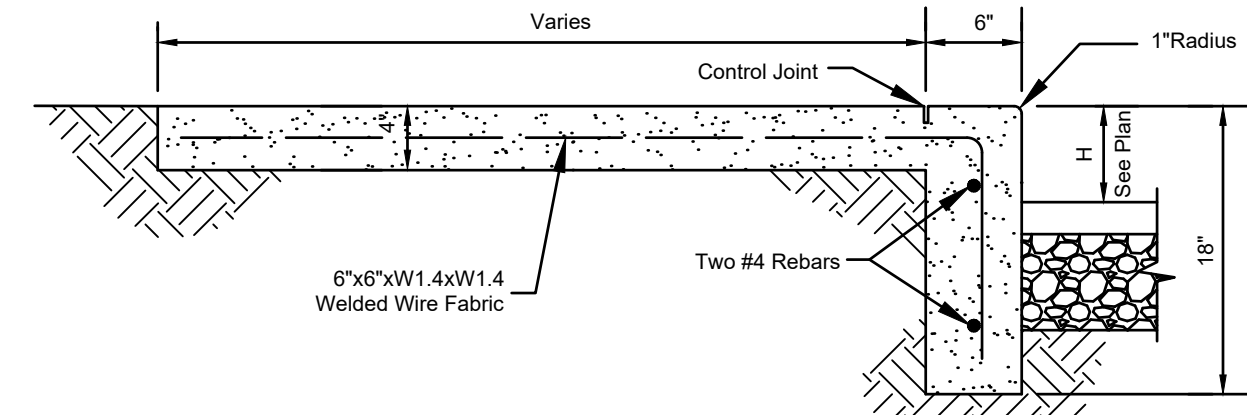

SIDEWALK INSTALLATION NOTES:
 1. EXPANSION JOINT MATERIAL SHALL BE INSTALLED IN THE WALK FOR ITS FULL WIDTH AND DEPTH AT INTERVALS OF APPROXIMATELY 55'. CONTROL JOINTS AT INTERVALS OF 1.5 TIMES ITS WIDTH.
 2. SIDEWALK CROSS SLOPE SHALL BE 1.0% - 1.5% (+2%) PER CURRENT ADA GUIDELINES.
 3. MATCH EXISTING SIDEWALK AND CURB JOINT LOCATIONS, WHERE APPLICABLE.
 4. WHERE EXTENDING EXISTING SIDEWALK, THE NEW SIDEWALK TO EXISTING WITH TYPE "D" JOINT WITH 6" REBAR, OR SIMILAR.
 5. INSTALL 4" THICK LAYER OF GRAVEL BASE COURSE WHERE NEW SIDEWALKS ARE ADJACENT THE BUILDING FOUNDATIONS.
 6. SEE ARCHITECTURAL PLANS FOR FROST HEAVE PROTECTION DETAILS.

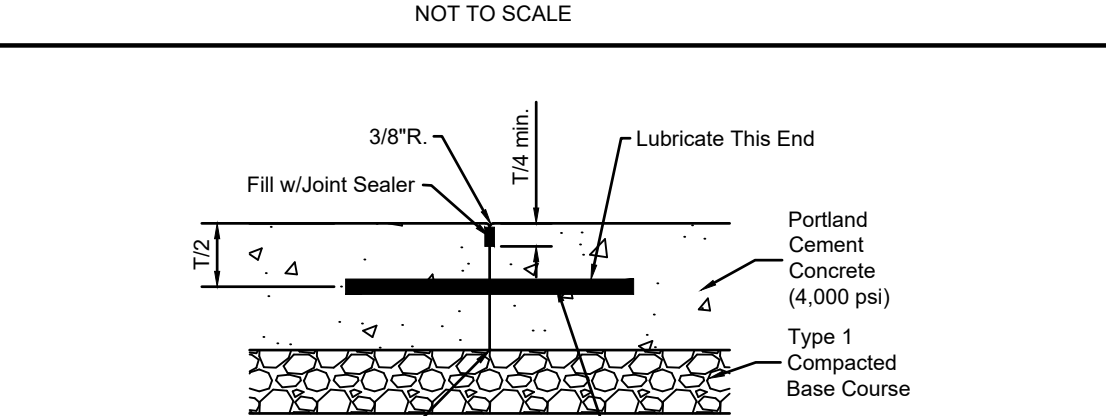
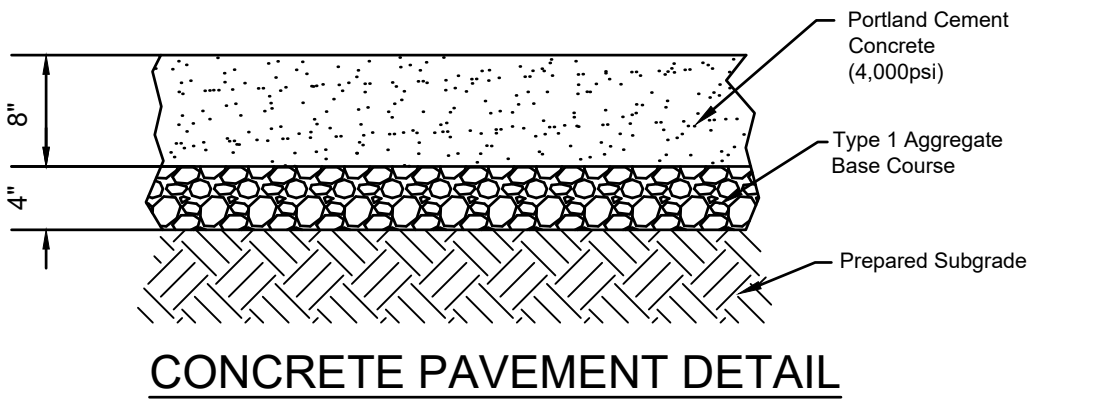
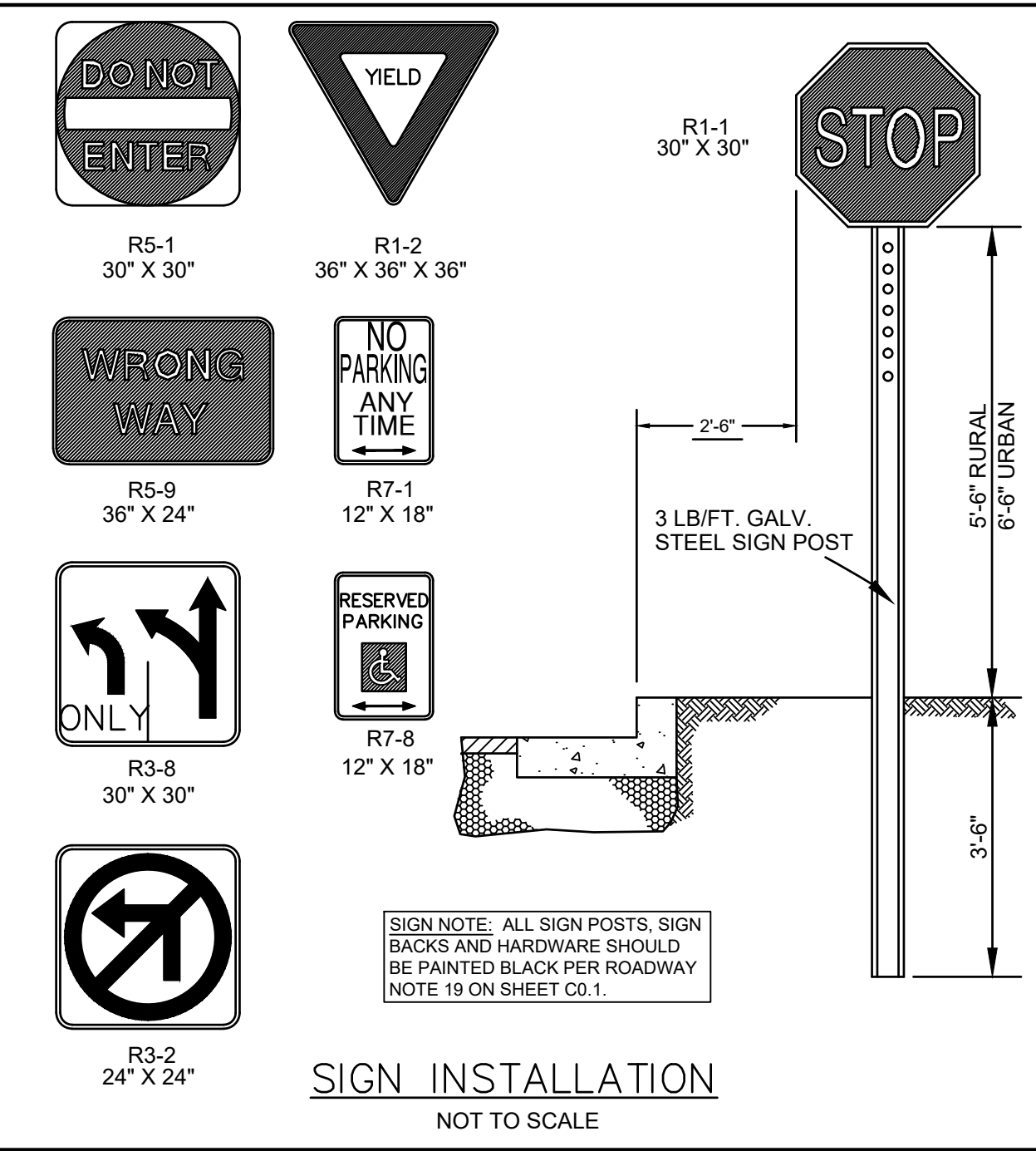

CONCRETE PAVEMENT JOINT DETAIL
 (for use at the end of each work day when pouring concrete and at connections between new & existing pavements & sidewalks)
 NOT TO SCALE

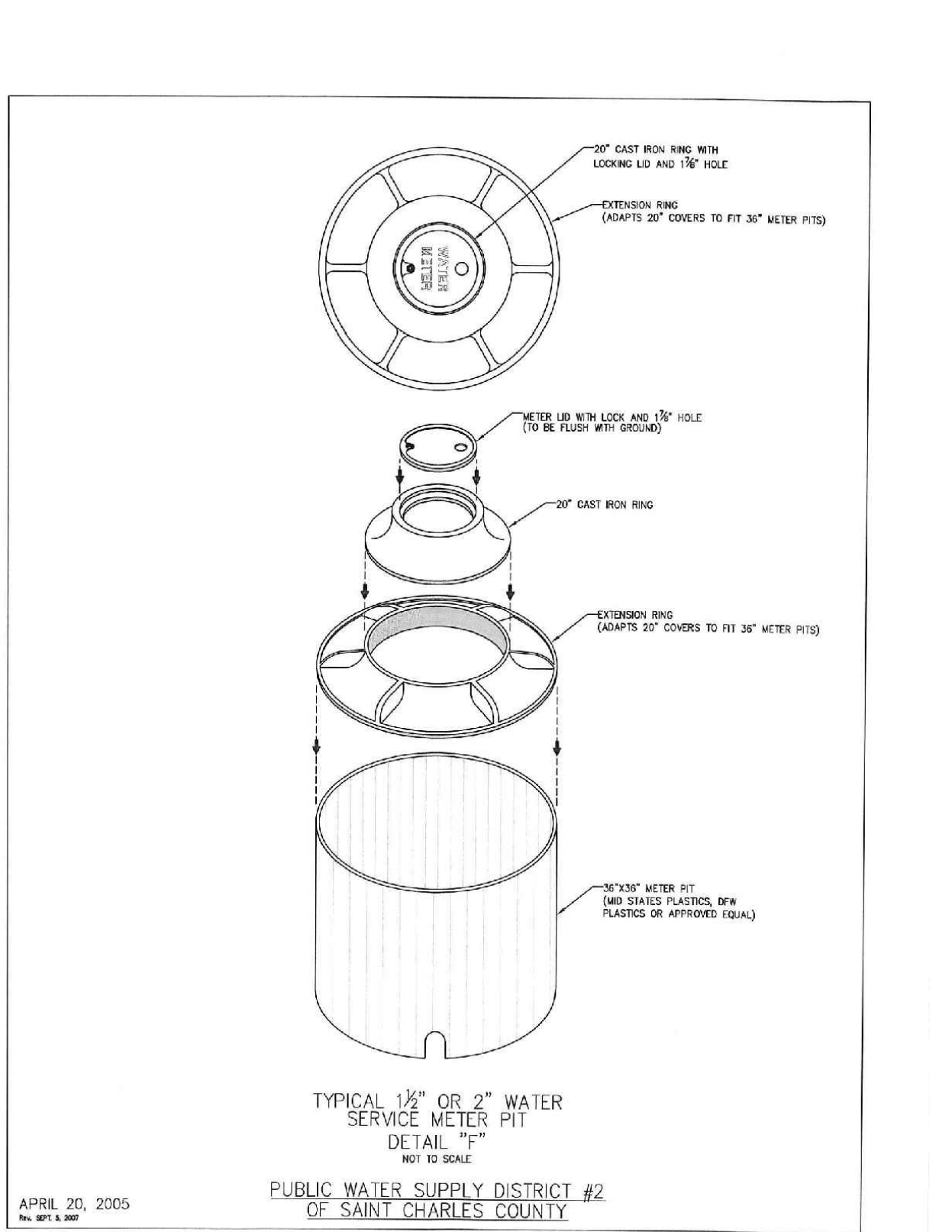
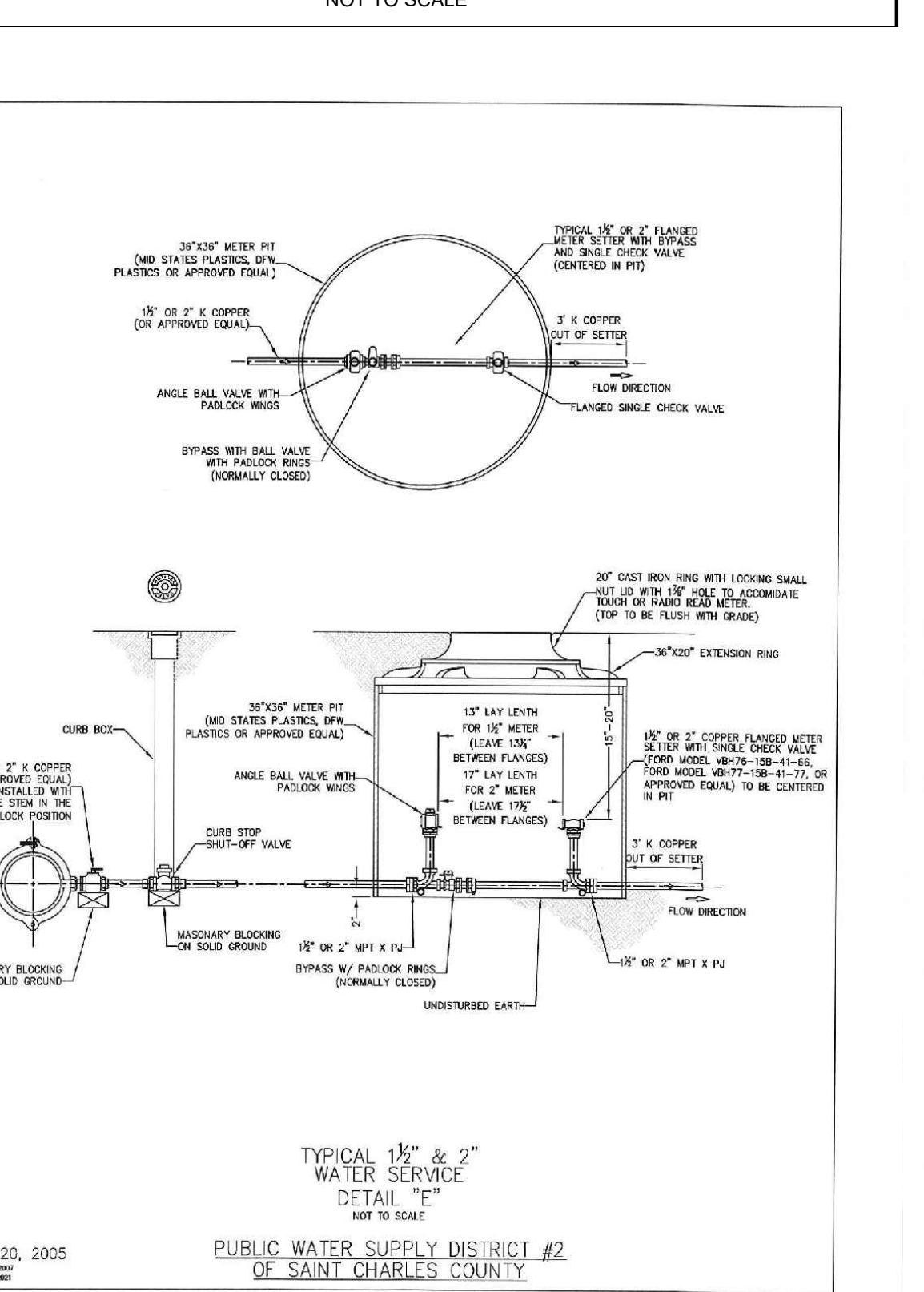
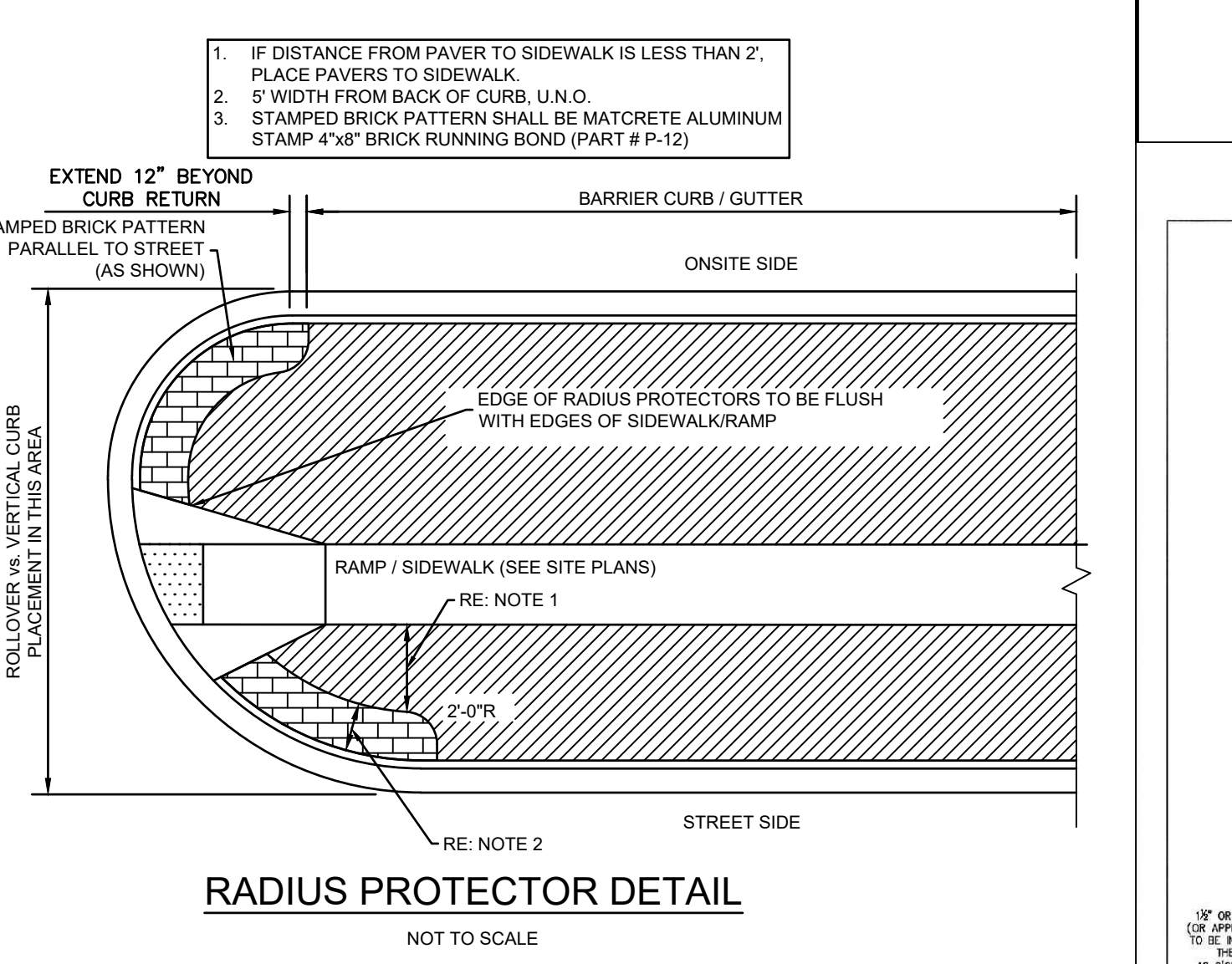
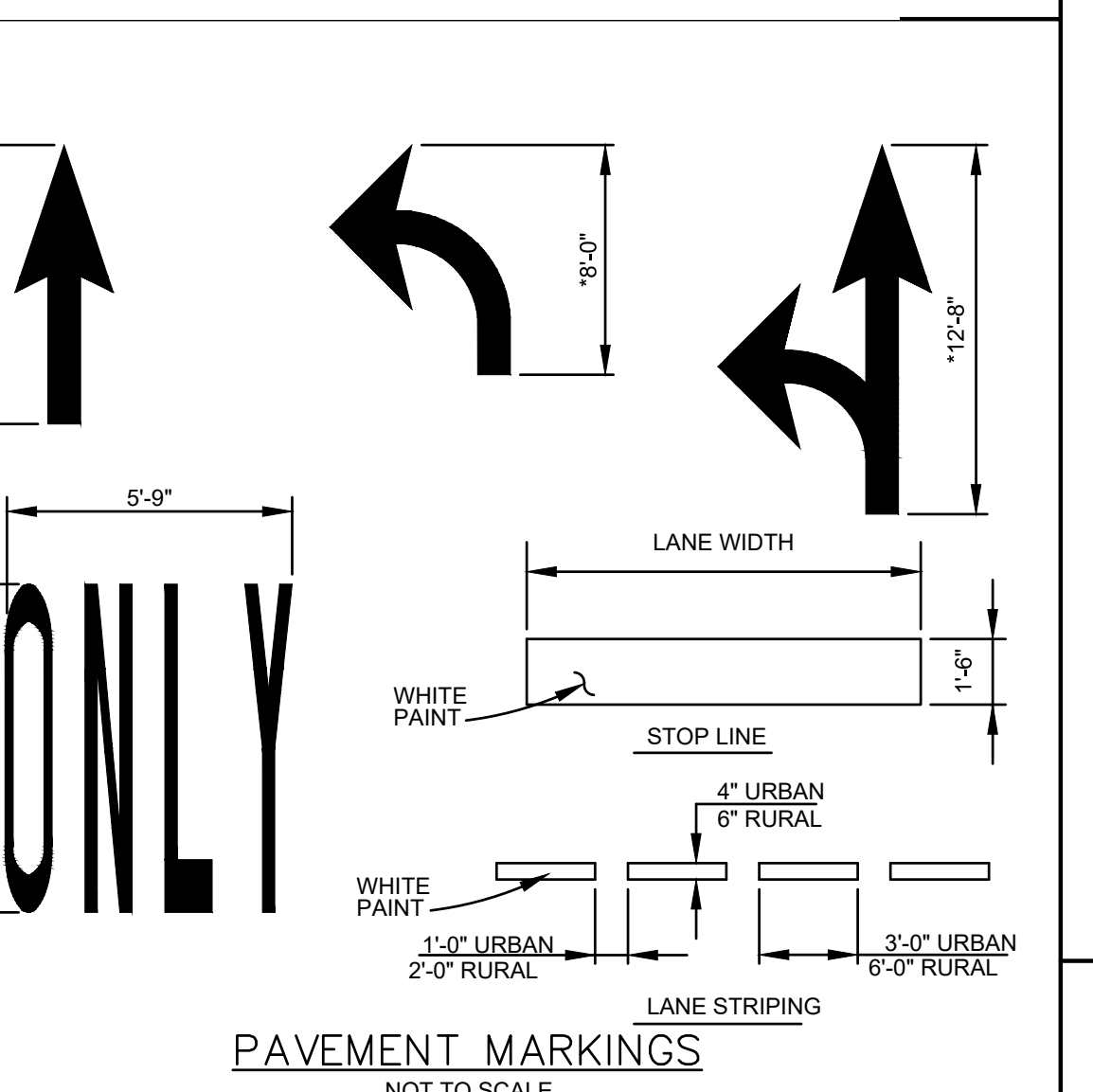
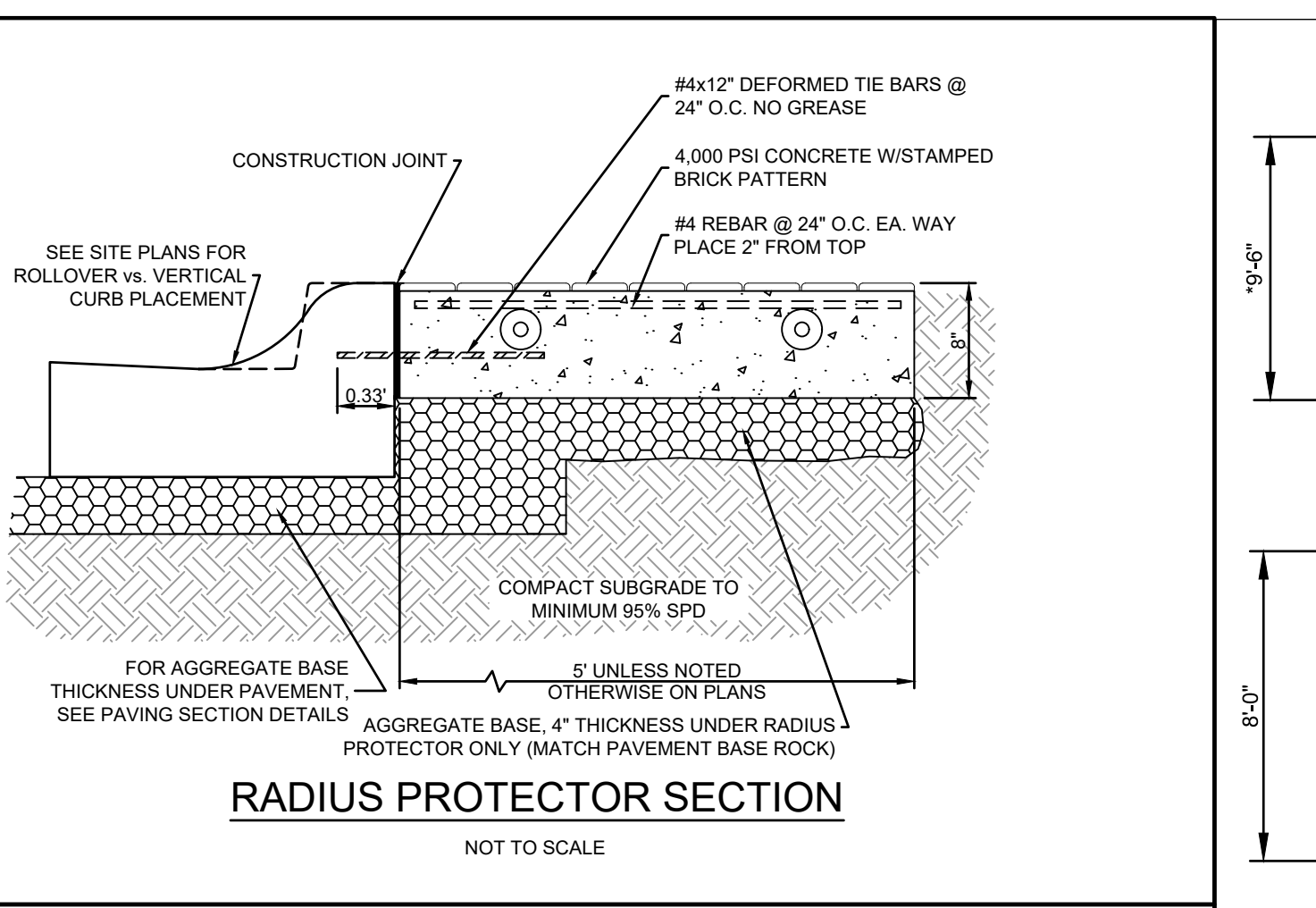
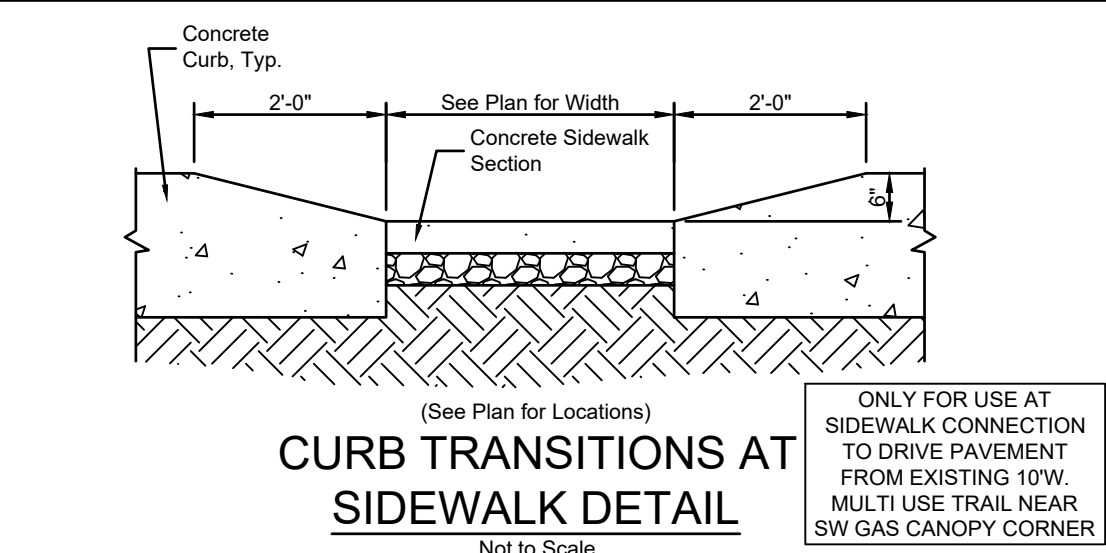
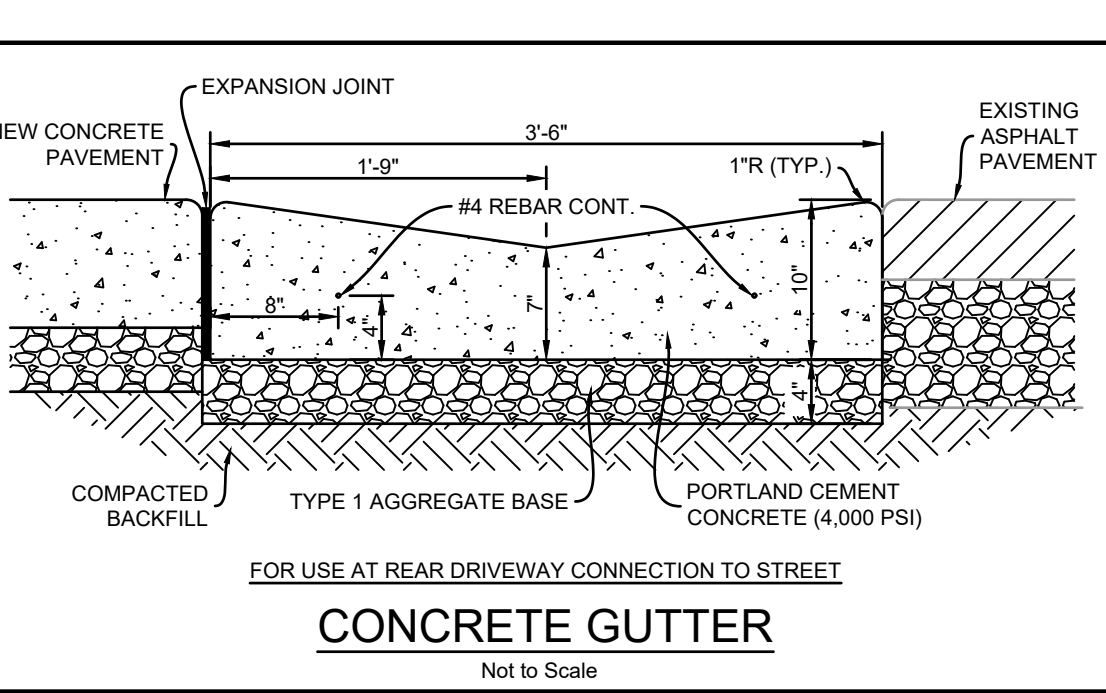
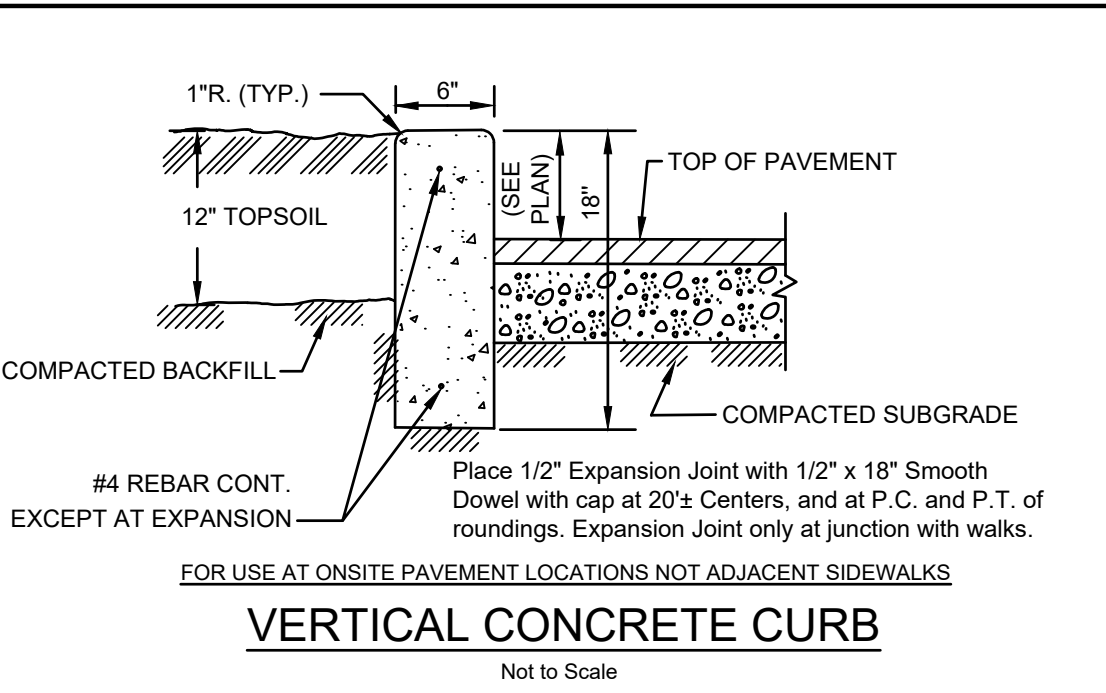

WATER SERVICE NOTE: 2" METER AND LINE - THE PUBLIC WATER SUPPLY DISTRICT NO. 2 WILL SUPPLY ONLY THE WATER METER, GASKETS AND BOLTS AND NUTS NEEDED TO COMPLETE THE SERVICE INSTALLATION. THE CONTRACTOR IS RESPONSIBLE FOR PROVIDING THE TAPPING SADDLE AS WELL AS EXCAVATION, TRENCHING, BACKFILLING AND INSTALLATION. IT SHALL BE WITNESSED AND INSPECTED BY THE WATER DISTRICT. 2" LINES CAN BE TYPE K COPPER ON DISCHARGE SIDE OF THE METER. ALL INSTALLATION TO FOLLOW PUBLIC WATER SUPPLY DISTRICT NO. 2 STANDARDS AND SPECIFICATIONS.

ADDITIONAL NOTES FOR CONCRETE & ASPHALT PAVING
 1. ALL NON-REINFORCED CONCRETE SHALL BE 4,000 P.S.I. AT 28 DAYS.
 2. THE ASPHALT SURFACE SHALL BE COMPACTED TO 98% MAXIMUM DENSITY.

fgma
 FGM Architects Inc.
 1 Metropolitan Sq. Ste. 1945
 St. Louis, Missouri 63102
 314.439.1601 OFFICE
 314.439.1602 FAX
 MISSOURI CERTIFICATE OF AUTHORITY #000311

ARCHITECTURE
 FGM ARCHITECTS
 1 METROPOLITAN SQ, STE. 1945
 ST. LOUIS, MISSOURI, 63102
 314.439.1601 (O) 314.439.1602(F)
 MO STATE CERTIFICATE OF AUTHORITY NO. 000311

CIVIL
 THE CLAYTON ENGINEERING COMPANY, INC.
 2288 WELSH INDUSTRIAL CT.
 ST. LOUIS, MO 63146
 314.692.8888 (O) 314.692.8888(F)
 MO STATE CERTIFICATE OF AUTHORITY NO. 000014
 PROF. ENG. NO. 000067 & PROF. SURVEYING NO. 000014

STRUCTURAL
 ASDG, LLC
 1009 LINCOLN HIGHWAY
 FAIRVIEW HEIGHTS, IL 62208
 618.272.0887 (O) 618.272.0889(F)
 IL STATE CERTIFICATE OF AUTHORITY NO. 184-00343

M.E.P
 BRIC PARTNERSHIP, LLC
 100 EAST WASHINGTON, SUITE 220
 BELLVILLE, IL 62220
 618.272.5200 (O) 618.272.5271(F)
 IL STATE CERTIFICATE OF AUTHORITY NO. 184-00343

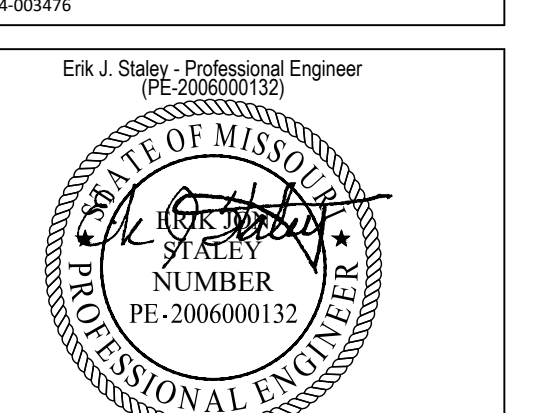

ERIK J. STALEY, PE
 ENGINEER No. 200600132
 The professional engineer seal offered to this sheet applies only to the material and items shown on this sheet. All drawings, instruments or other documents not containing this seal shall not be considered prepared by this engineer, and this engineer expressly disclaims any and all responsibility for such plans, drawings or documents not exhibiting this seal.
 DATE 08/25/2021

NO	DATE	DESCRIPTION
1.	08/25/21	CITY SUBMITTAL
2.	09/22/21	2nd CITY SUBMITTAL
3.	10/06/21	3rd CITY SUBMITTAL
4.	11/22/21	4th CITY SUBMITTAL (BID SET)

O'FALLON, MO MOTOMART
 NEW CONVENIENCE CENTER
 AND CARWASH
 FKG OIL COMPANY
 CONSTRUCTION DETAILS 2

SHEET NO. **C6.1**
 JOB NO. 21-3133.01
 © 2021 FGM Architects Inc.

Call Before you DIG
 Dial 811 or TOLL FREE
 1-800-344-7483
 mo1call.com
 MISSOURI ONE-CALL SYSTEM INC.
 Underground facilities, structures & utilities have been plotted from available surveys, records & information, and therefore, do not necessarily reflect the actual existence, nonexistence, size, type, number, or location of these facilities, structures, & utilities.
 The Contractor shall be responsible for verifying the actual location of all underground facilities, structures, & utilities, either shown or not shown on these plans. The underground facilities, structures, & utilities shall be located in the field prior to any grading, excavation or construction of improvements. These provisions shall in no way absolve any party from complying with the Underground Facility Safety and Damage Prevention Act.

The original signed and sealed of this drawing is on file at the office of The Clayton Engineering Company. Any modifications to this drawing shall release said The Clayton Engineering Company, the Engineer and/or Surveyor whose seal appears hereon from any liability resulting from said unauthorized modifications. The signed and sealed original is the official document and shall take precedence over any digital version.

APRIL 20, 2025
 PUBLIC WATER SUPPLY DISTRICT #2
 OF SAINT CHARLES COUNTY

APRIL 20, 2025
 PUBLIC WATER SUPPLY DISTRICT #2
 OF SAINT CHARLES COUNTY

PRINTED ON 24" x 36" SHEET
 Project Number: 20350
 PLOTTED: 11/22/2021 10:33 AM BY: ERIC STALEY
 FILE: C:\2021\20350_MOTOMART\DWG\Plan\Main\Main.dwg
 Copyright 2021 Clayton Engineering Co. All Rights Reserved
 Designed: EJS / RPK
 Drawn: EJS / RPK
 T.B. 1447

the clayton engineering company, inc.
 ENGINEERS • SURVEYORS • PLANNERS
 2288 WELSH INDUSTRIAL COURT
 ST. LOUIS, MISSOURI 63146
 (314) 692-8888 FAX: (314) 692-8888 claytoneng.com
 Mo. Cert. of Authority - Prof. Engineering #000067
 & Prof. Surveying #000014
 Il. Dept. Financial & Prof. Reg. Prof. Design & Engineering Corp. #184-00079