

SIZE	CATALOG NO.	A	B	C	D	E	F	G	H	CT	PT
4"	334-040	4.56	8.23	4.25	4.10	3.94	4.80	2.72	2.7	.32	.25
6"	334-060	6.68	9.93	6.31	4.57	5.88	6.90	3.72	3.5	.45	.36

Duckett Creek Sanitary District

SDR-35 x C900 BELL AND SPIGOT ADAPTERS
 Own By: BSM App By: KLA Detail No. 19A
 Cld By: MDOB Date: 1-3-01

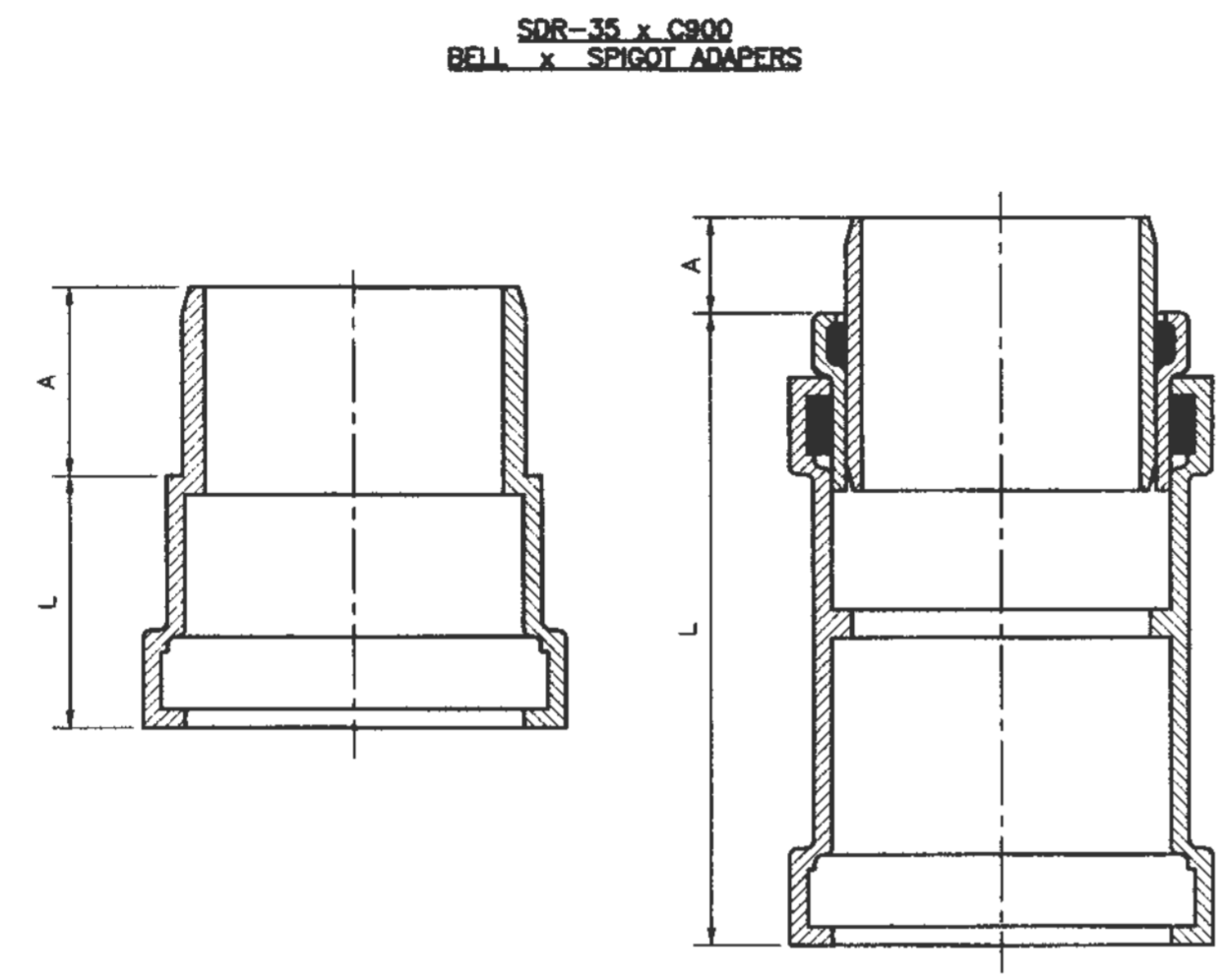

SIZE	CATALOG NO.	A	L	STYLE
4"	335-040	3.2	10.0	FABRICATED
6"	335-060	2.9	3.5	HARCO
8"	335-080	4.0	12.5	FABRICATED

Duckett Creek Sanitary District

SDR-35 x C900 BELL AND SPIGOT SPECIAL 4", 6" & 8" ADAPTERS
 Own By: BSM App By: KLA Detail No. 19B
 Cld By: MDOB Date: 1-3-01

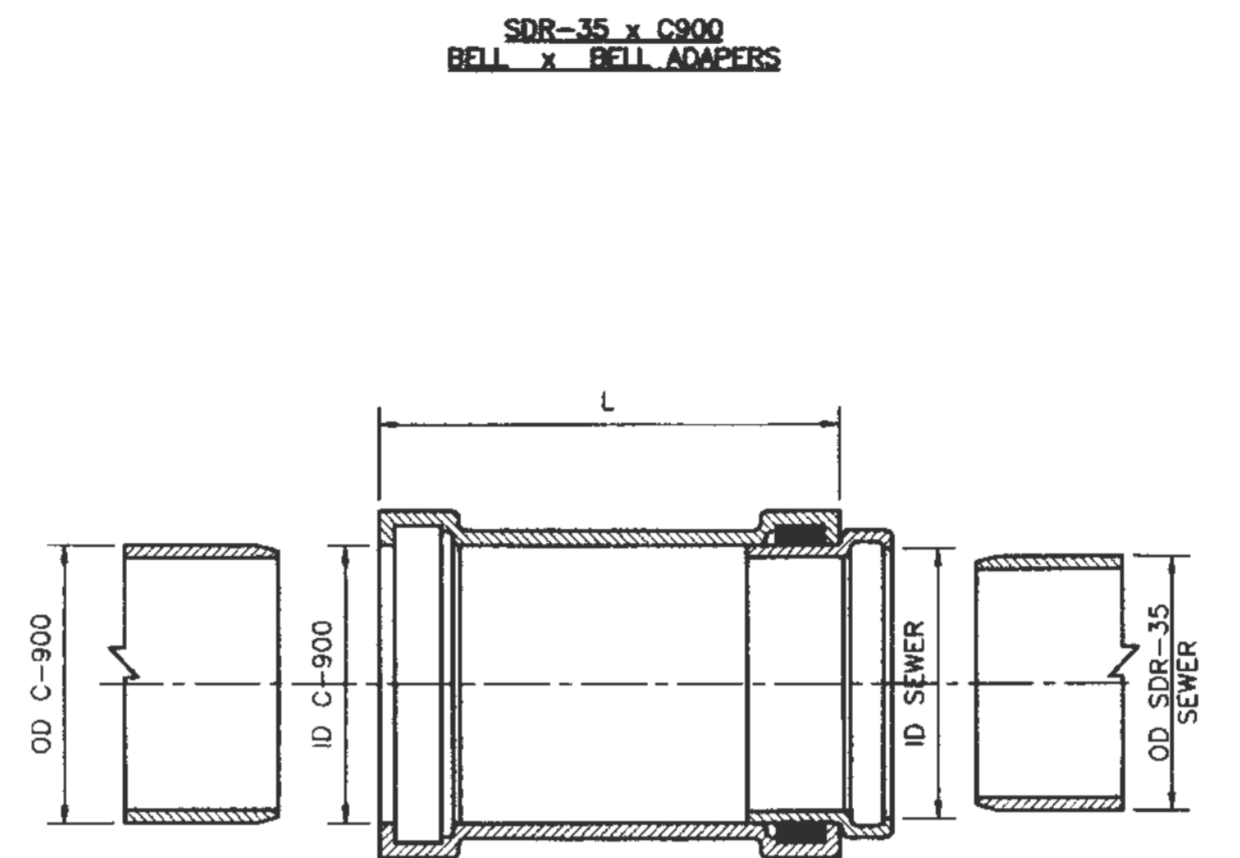

SIZE	CATALOG NO.	OD C900 SEWER	OD C900 SEWER	ID C900 SEWER	ID C900 SEWER	L	CTN QTY	CTN WT
4x4	337-040	4.80	4.215	4.86	4.25	10.0	1	4
6x6	337-060	6.90	6.275	6.96	6.32	11.13	1	8
8x8	337-080	9.05	8.400	9.13	8.45	12.50	1	15

Duckett Creek Sanitary District

SDR-35 x C900 BELL AND BELL 4", 6" & 8" ADAPTERS
 Own By: BSM App By: KLA Detail No. 19C
 Cld By: MDOB Date: 1-3-01

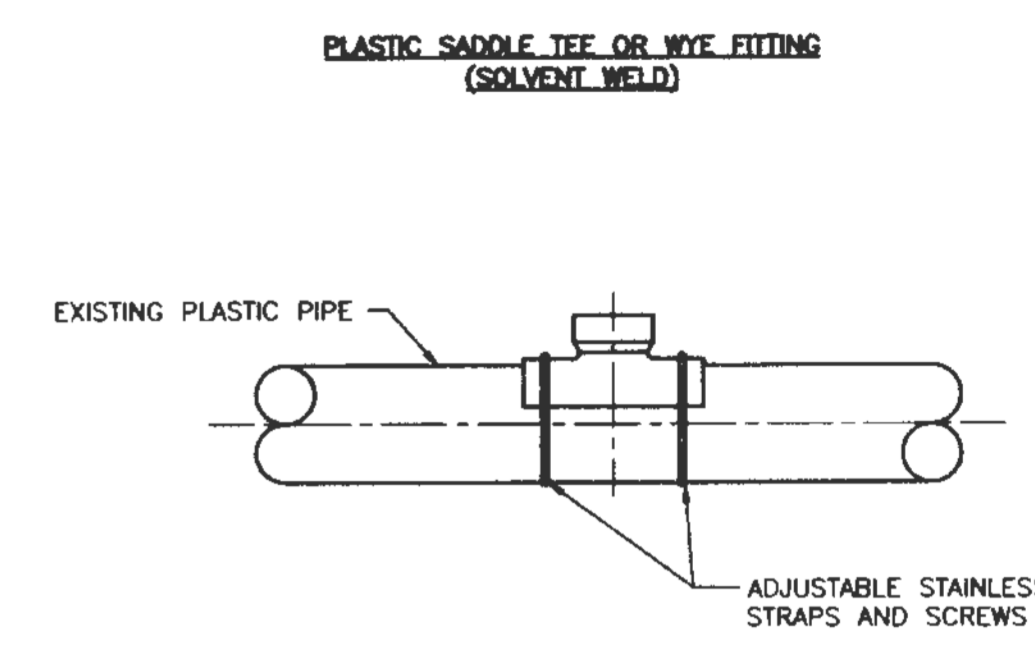

WHEN CONNECTION TO A PLASTIC PIPE IS ALLOWED AND A CONNECTION IS LARGER THAN 6" IN DIAMETER, A SOLVENT WELD WYE OR TEE FITTING OF A SIMILAR MATERIAL MUST BE USED. (EXAMPLE: 10" x 8") THIS IS ACCOMPLISHED BY CAREFULLY CUTTING A HOLE WITH A SAW IN THE MAIN AT THE REQUIRED LOCATION AFTER CUTTING AND SHAPING THE HOLE TO THE SIZE OF THE FITTING. THE FOLLOWING STEPS SHOULD BE TAKEN.

- CLEAN AND DRY BOTH INSIDE THE SADDLE WYE SURFACE AND PIPE SURFACE TO BE SOLVENT CEMENTED.
- IMPORTANT: APPLY A LIBERAL, HEAVY COAT OF ONE-STEP SOLVENT CEMENT TO THE INSIDE SURFACE OF THE SADDLE WYE AND TO THE EXTERIOR WELDING SURFACE TO THE PIPE.
- WITHOUT DELAY, MATE THE SURFACES AND STRAP DOWN TIGHTLY. A BEAD OF SOLVENT SHOULD APPEAR AFTER THE SADDLE HAS BEEN STRAPPED DOWN TIGHTLY.
- USING A RAG OR PAPER TOWEL, WIPE BEAD AND ANY EXCESS SOLVENT CEMENT OFF PIPE AND SADDLE.
- ALLOW 30-60 MINUTES FOR SET-UP TIME BEFORE BACKFILLING. CURE TIME DEPENDS ON SIZE FIT OF MATERIALS BEING INSTALLED AND VARIOUS COLD DAMP CONDITIONS.
- DISCARD OLD SOLVENT IF IT BECOME JELLED OR LUMPY.
- A CLEAN, DRY BEDDING MATERIAL IS REQUIRED AROUND THE COMPLETED CONNECTION BEFORE BACKFILLING. THE BEDDING MATERIAL SHOULD BE ONE OF THE FOLLOWING:
 - A 1 TO 3 CEMENT TO SAND MIX
 - "PRE-MIX" CONCRETE
 - CCSD APPROVED BEDDING FOR SANITARY SEWERS.

Duckett Creek Sanitary District

8" & LARGER CONNECTION TO PLASTIC MAIN
 Own By: BSM App By: KLA Detail No. 20A
 Cld By: MDOB Date: 1-4-01

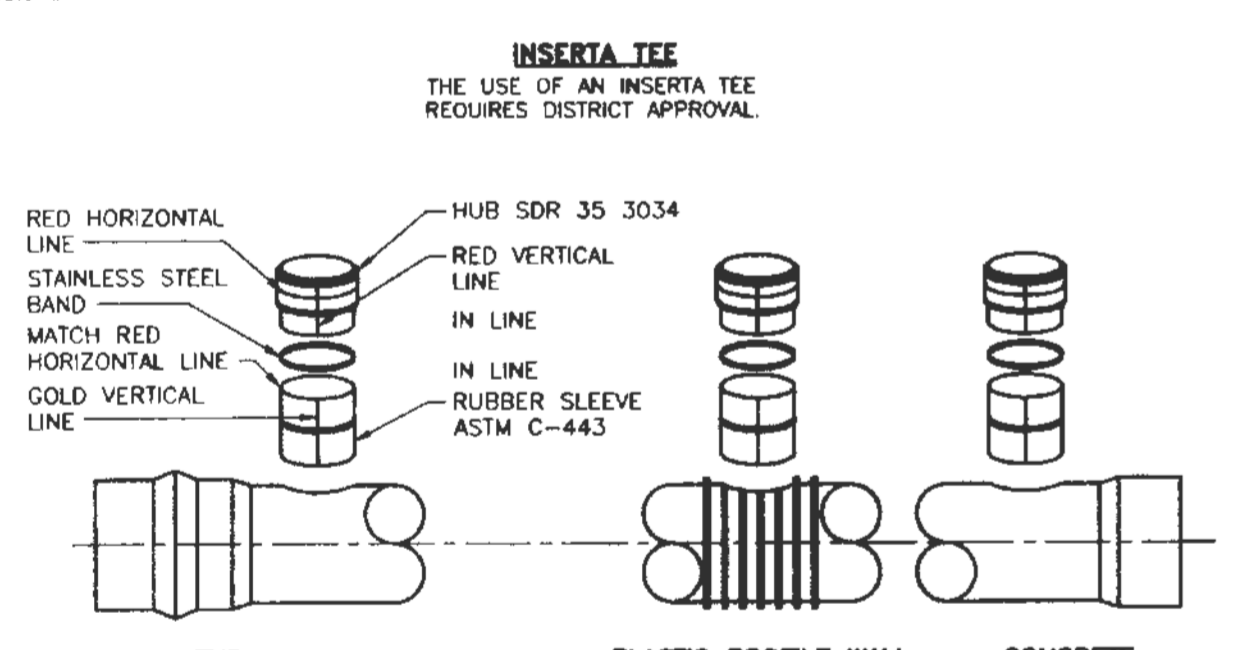

- INSTALLATION PROCEDURE:**
- CORE THE PROPER SIZE HOLE. TEE SIZE: 4" 6" 8" 10" 12" 15" BIT SIZE: 4 1/2" 6 1/2" 8 1/2" 10 1/2" 12 1/2" 15 1/2"
 - INSERT THE RUBBER SLEEVE (1) IN THE CORED HOLE WITH THE GOLD VERTICAL LINE ON THE RUBBER SLEEVE (2) FACING TO THE SIDE OF THE MAIN LINE. THE UPPER SEGMENT SHOULD BE ON TOP OF THE WALL OR RIB AND THE LOWER SEGMENT (PVC, PROFILE WALL, AND POLYETHYLENE PIPE ONLY) SHOULD BE ON THE INSIDE OF THE PIPE.
 - APPLY THE INSERTA TEE SOLUTION SUPPLIED TO THE INSIDE OF THE RUBBER SLEEVE AND TO THE OUTSIDE OF THE PVC HUB ADAPTER. CAUTION - DO NOT USE AN OIL BASED LUBRICANT.
 - PLACE THE PVC HUB ADAPTER (3) INTO THE RUBBER SLEEVE. MAKE SURE THAT THE RED VERTICAL LINE (4) ON THE PVC HUB ADAPTER IS IN LINE WITH THE GOLD VERTICAL LINE (2) ON THE RUBBER SLEEVE.
 - PLACE THE 2x4 BOARD ONTO THE TOP OF THE PVC HUB ADAPTER.
 - THE RED HORIZONTAL LINE (5) AT THE TOP OF THE HUB ADAPTER IS A DEPTH MARK. THIS TELLS THE INSTALLER HOW FAR TO DRIVE THE ADAPTER INTO THE RUBBER SLEEVE. DRIVE THE PVC HUB ADAPTER INTO THE RUBBER SLEEVE TO WHERE THE HORIZONTAL RED LINE (5) ON THE PVC HUB ADAPTER (3) MEETS THE TOP OF THE RUBBER SLEEVE (2).
 - PLACE THE STAINLESS STEEL BAND (7) AROUND THE TOP OF THE RUBBER SLEEVE AND TIGHTEN DOWN.
 - INSTALL PIPE IN NORMAL MANNER.

Duckett Creek Sanitary District

INSERTA TEE DETAILS AND SPECIFICATIONS
 Own By: BSM App By: KLA Detail No. 20B
 Cld By: MDOB Date: 1-4-01

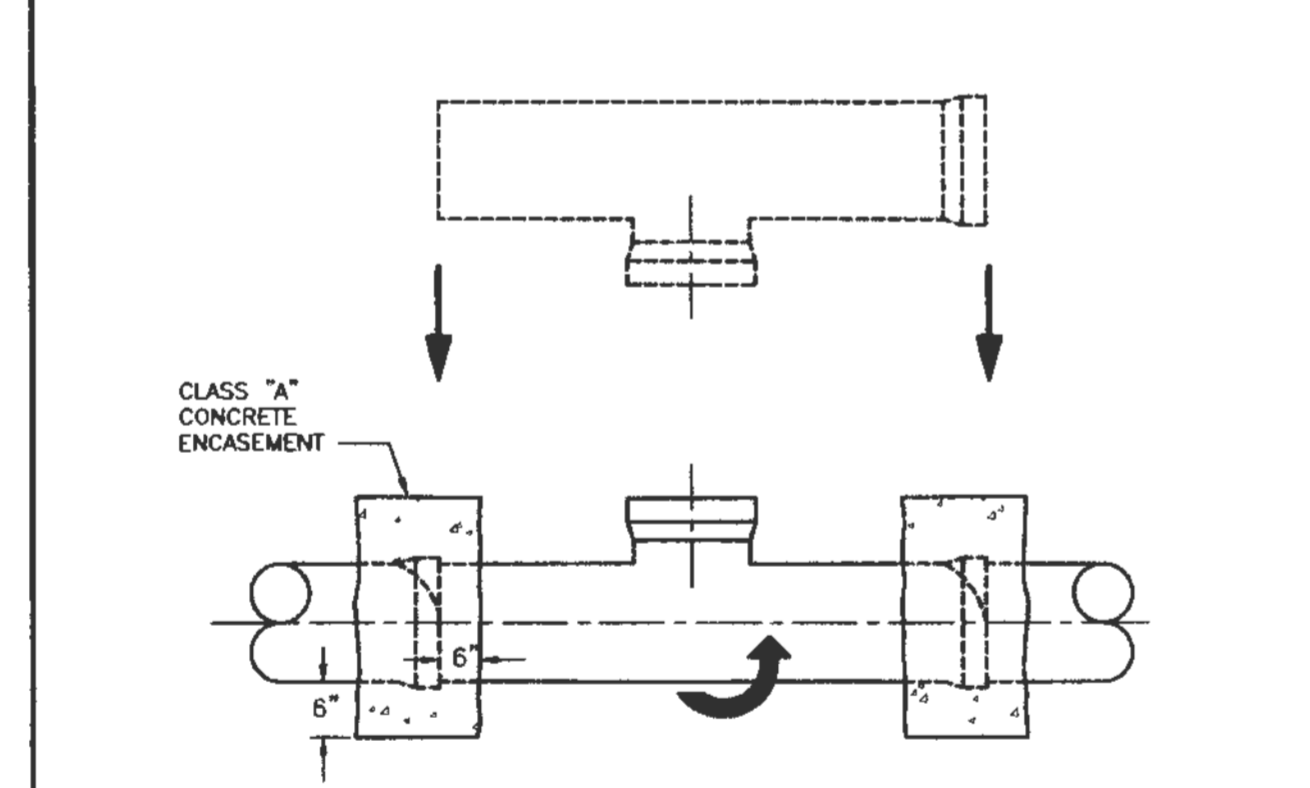

- NOTES:**
- WHEN A CONNECTION IS ALLOWED LARGER THAN 6" DIAMETER A SADDLE MAY BE USED IF THE I.D. OF THE CONNECTION PIPE IS NOT GREATER THAN ONE HALF (1/2) OF THE I.D. OF THE MAIN SEWER. (EXAMPLE: 24" x 10")
 - IF THE I.D. OF THE CONNECTION PIPE IS GREATER THAN ONE HALF (1/2) THE I.D. OF THE MAIN SEWER THE WYE OR TEE MUST BE "ROLLED IN". (EXAMPLE: 15" x 8")
 - THIS IS ACCOMPLISHED BY BREAKING AWAY AND REMOVING ONE SECTION OF PIPE. THE TOP HALF OF THE BELL ON THE PIPE LYING ADJACENT TO THE GAP IS CAREFULLY BROKEN OFF. THE TOP HALF OF THE BELL ON THE MAIN REPLACEMENT SECTION (WITH A "TEE" WYE?) FITTING IS ALSO BROKEN OFF. THE REPLACEMENT PIPE IS THEN PLACED IN THE LINE GAP WITH THE STUD POINTED IN THE WRONG DIRECTION. THE BROKEN BELLS ON THE REPLACEMENT AND ADJOINING PIPE MAKE IT POSSIBLE FOR THE REPLACEMENT SECTION TO FIT INTO THE SEWER LINE WITHOUT DISTURBING THE ADJOINING PIPE SECTIONS. THE REPLACEMENT SECTION IS THEN ROTATED TO THE DESIRED POSITION AND THE BROKEN BELLS ARE ENCASED WITH A 6" CLASS "A" CONCRETE ENCASEMENT.
 - ID OF MAIN SEWER SHALL NOT BE DECREASED BY A ROLL-IN CONNECTION.

Duckett Creek Sanitary District

"ROLL-IN" (FOR EXISTING CLAY OR CONCRETE PIPE)
 Own By: BSM App By: KLA Detail No. 21
 Cld By: MDOB Date: 1-5-01

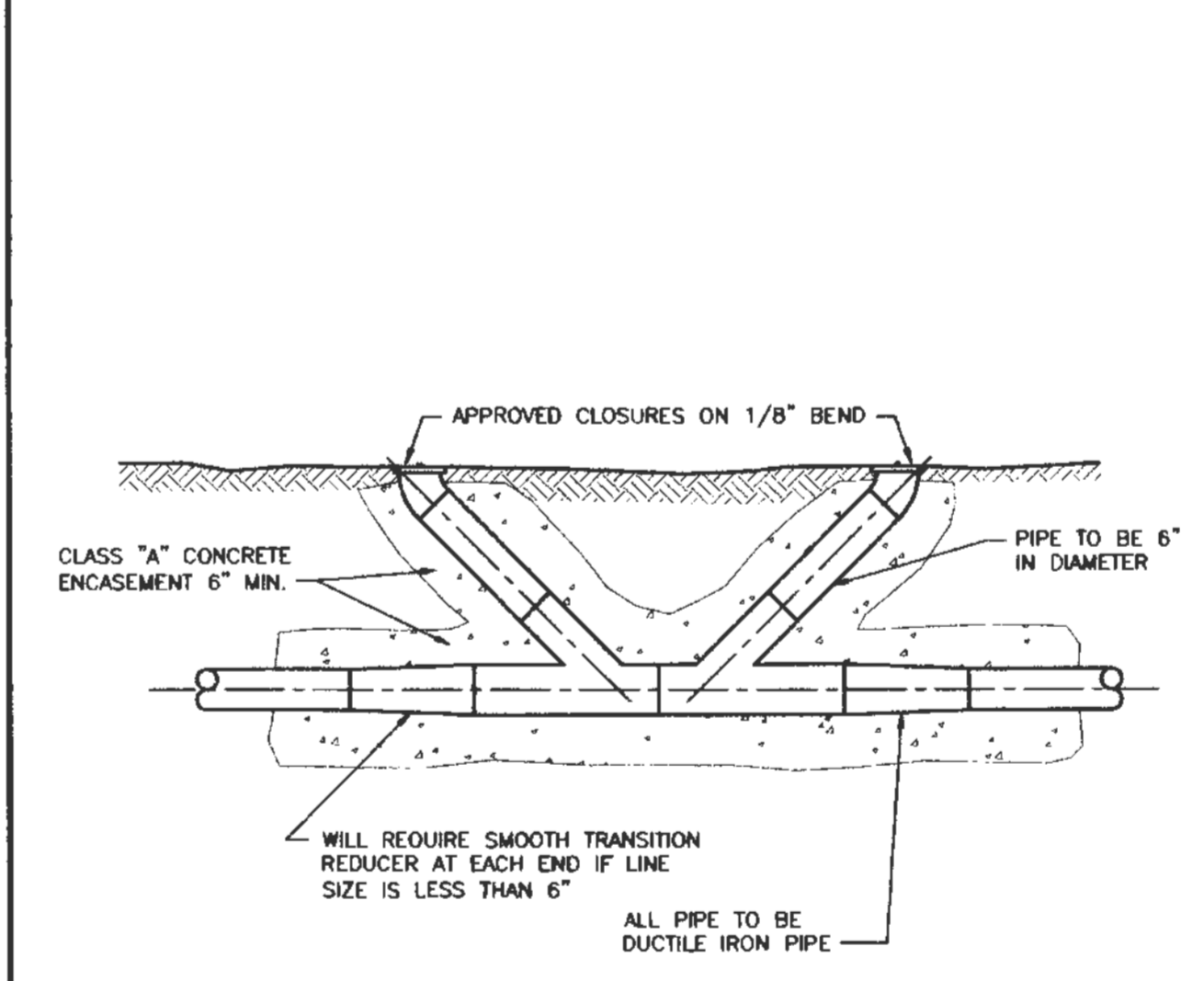

1800' MAXIMUM SPACING

Duckett Creek Sanitary District

FORCE MAIN CLEANOUT (6" DIA. & SMALLER)
 Own By: BSM App By: KLA Detail No. 22
 Cld By: MDOB Date: 1-5-01

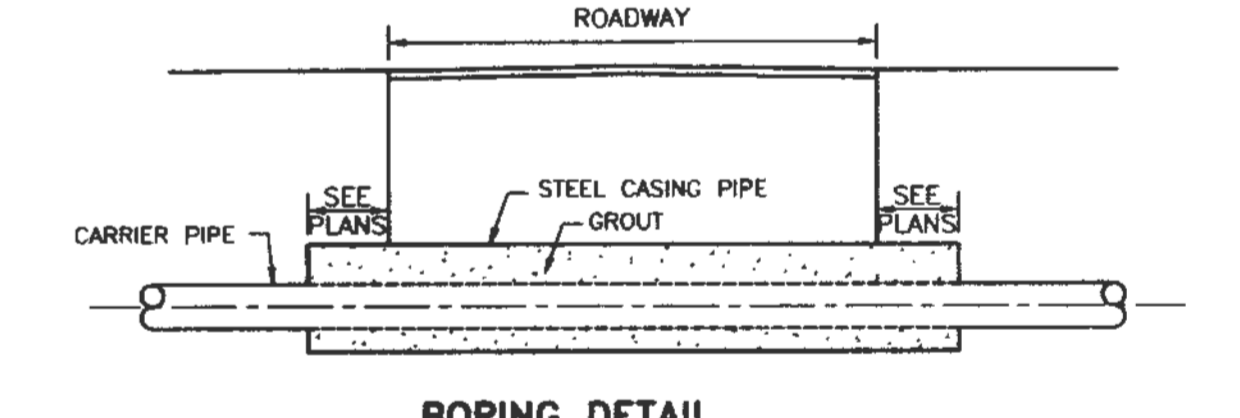

- NOTES:**
- INSIDE DIAMETER OF CASING PIPE TO BE MINIMUM OF 4" GREATER THAN COUPLING DIAMETER OF CARRIER PIPE.
 - ENCASEMENTS TO BE INSTALLED UNDER THE ROAD BY MEANS OF JACKING IT THROUGH, OR BY DRY BORING A HOLE THAT WILL RECEIVE THE CASING WITH A SNUG FIT.
 - THE OUTSIDE DIAMETER OF THE CASING SHALL NOT BE LESS THAN, NOR MORE THAN ONE INCH GREATER THAN THE BORED HOLE.
 - THE ANNULAR SPACE BETWEEN THE CASING PIPE AND THE BORED HOLE SHALL BE FILLED WITH GROUT.

SUPPORT OF CARRIER PIPE OR FORCE MAIN IN CASING

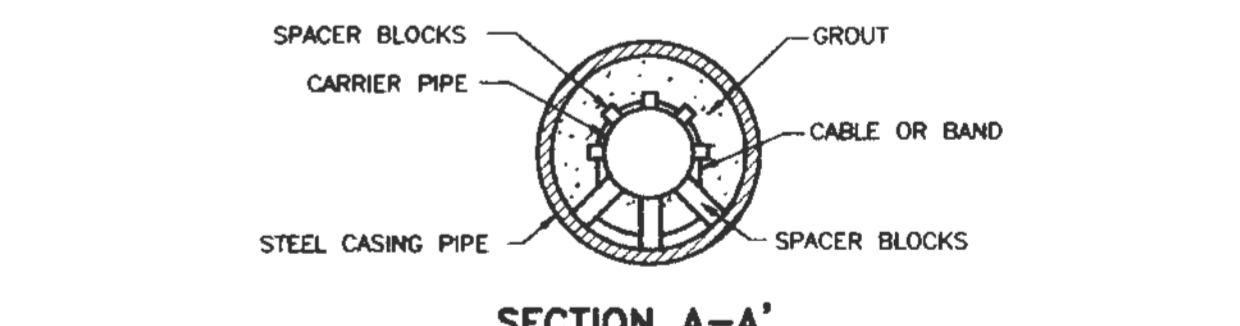

Duckett Creek Sanitary District

ROADWAY BORING DETAIL
 Own By: BSM App By: KLA Detail No. 23
 Cld By: MDOB Date: 1-5-01

PROJECT TITLE

MUIRFIELD MANOR

PRS No. 13033MCHO.00R

PICKETT, RAY & SILVER INC

CIVIL ENGINEERING, LAND SURVEYING, AND NATURAL RESOURCES SERVICES
 St. Peters, Missouri, MO 66156
 Phone: (636) 397-1211 Fax: (636) 397-1104
 www.prs3.com

ENGINEERS AUTHORIZATION
 THE RESPONSIBILITY FOR PROFESSIONAL ENGINEERING LIABILITY ON THIS PROJECT IS LIMITED TO THE SET OF PLANS AUTHORIZED BY THE SEAL, SIGNATURE, AND DATE HEREON AFFIXED. RESPONSIBILITY IS DECLINED FOR ALL OTHER ENGINEERING PLANS THROUGHOUT THIS PROJECT AND SPECIFICALLY FOR ALL REVISIONS AFTER THIS DATE UNLESS REAUTHENTICATED.

PICKETT, RAY & SILVER, INC. MO LICENSE #000285

Handwritten signature and date

EDDIE S. TIDWELL PROFESSIONAL ENGINEER LICENSE E-23345

Developer / Owner Information

MCKELVEY HOMES
 218 Chesterfield Towne Centre
 Chesterfield, Missouri 63005
 Phone: 636-630-6900

MCKELVEY HOMES
 Building A, Inc. (a wholly owned subsidiary of PulteGroup, Inc.)

CITY OF O'FALLON - Duckett Creek Sanitary District Details

P+Z No.

City No.

Page No.

I:\PRIS\6852011\Projects\Call 3D\Projects\13033\DWG\Water & Sanitary\Drawings.dwg 12/27/2015 2:58:14 PM dclan