

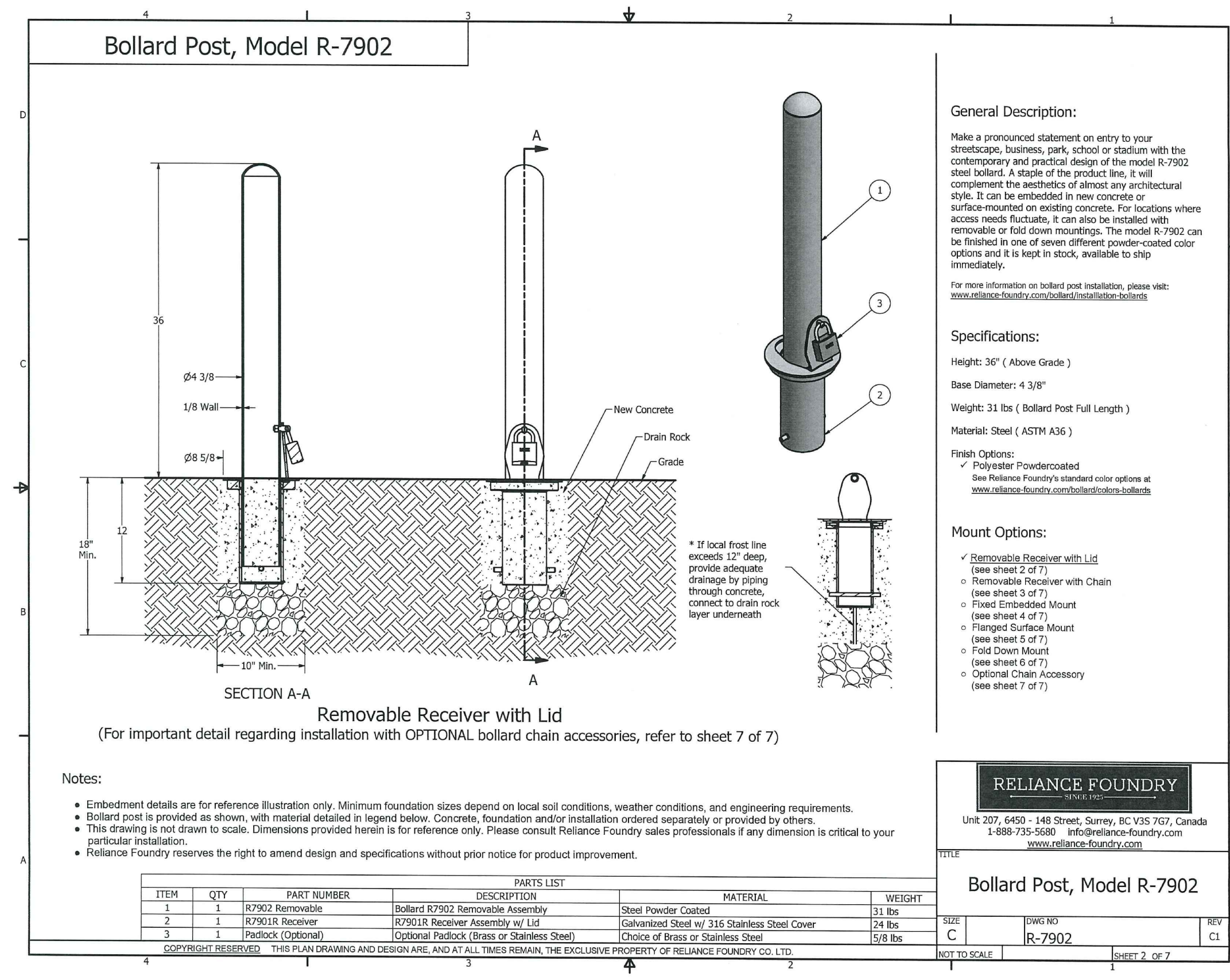

No.	Description	Date
02	PRELIM P&Z	04/28/17
03	P&Z RESUBMIT	05/17/17
04	100% DD SET	06/09/17
05	50% CD SET	07/14/17
06	90% CD SET	08/01/17
07	PERMIT SET	08/18/17
08	PERMIT SET	09/22/17
	FIRE DEPT.	
09	PERMIT SET	10/04/17
	REVISIONS	

No.	Description	Date



B REMOVABLE BOLLARD - DETAIL
SCALE: NTS

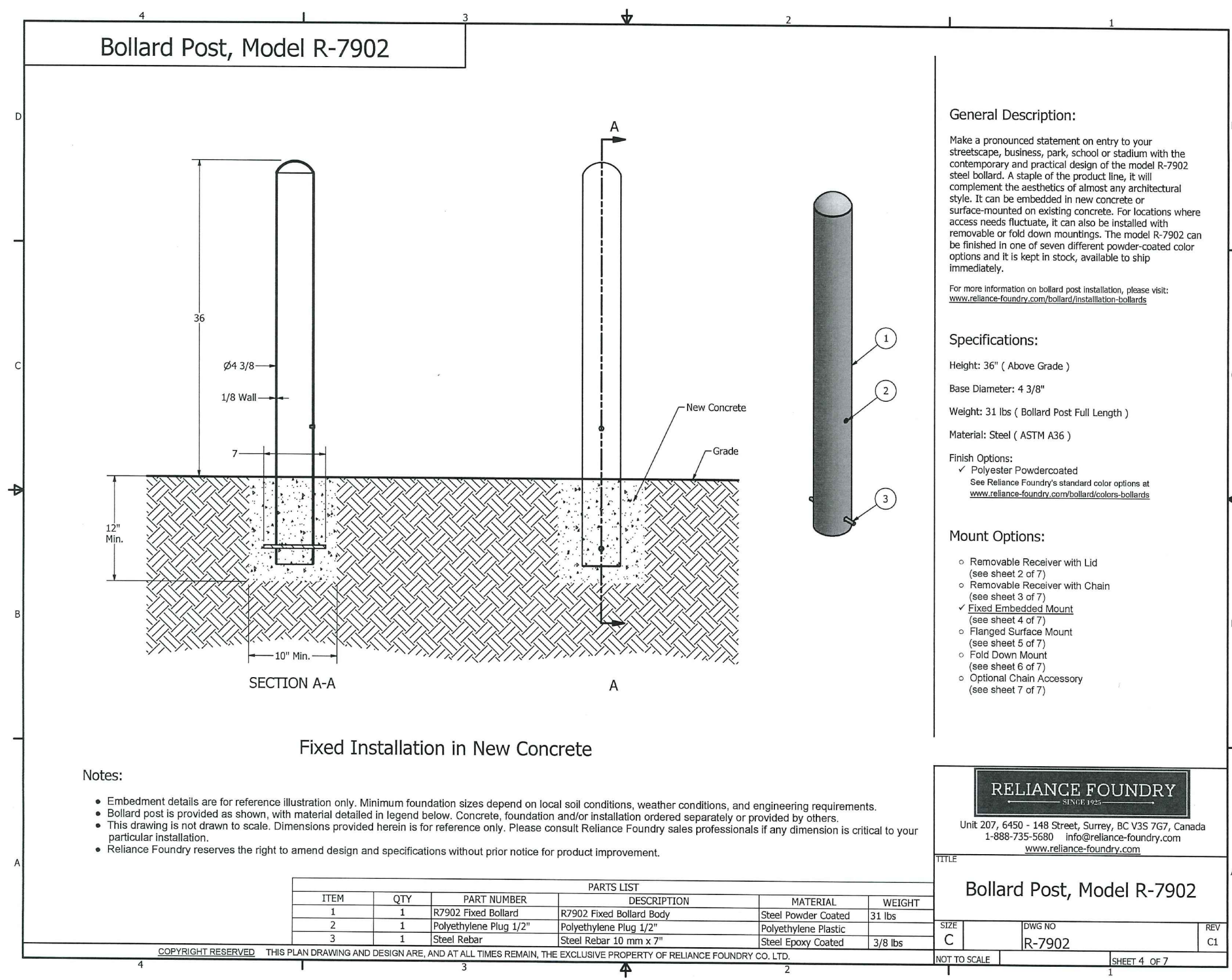

A FIXED BOLLARD - DETAIL
SCALE: NTS

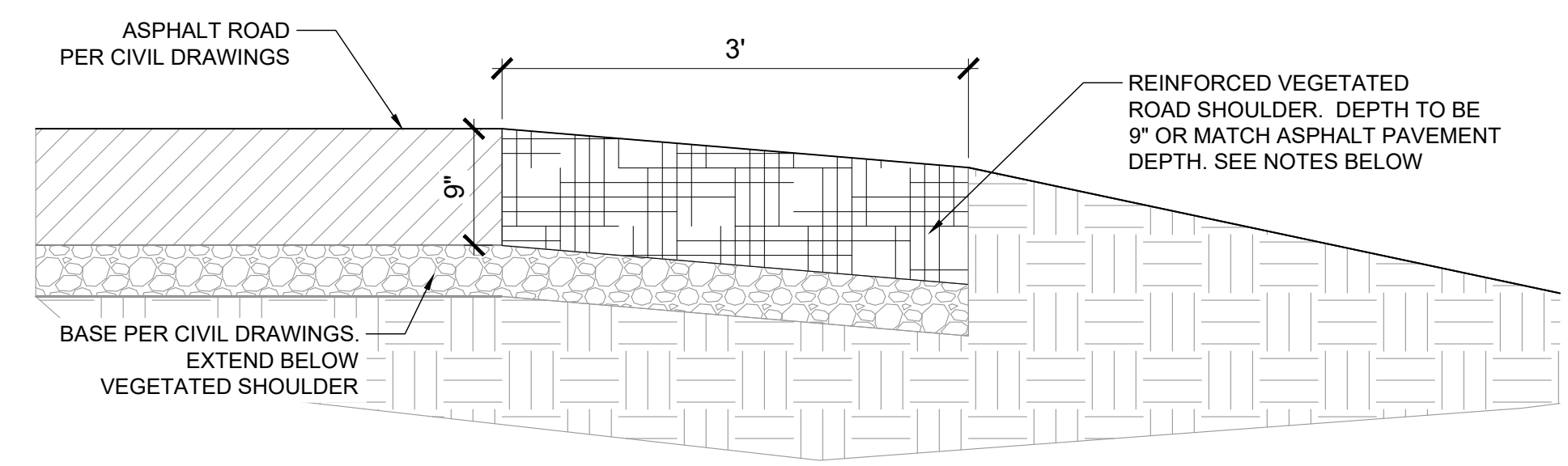

- NOTES:**
- SOIL FOR REINFORCED VEGETATED ROAD SHOULDER TO BE SOIL GRAVEL MIX. TWO COMPONENTS OF THE SOIL MIX SHALL BE COMBINED IN THE FOLLOWING PROPORTIONS BY WEIGHT:
-100 PARTS: 3/4" - 1 1/2" CLEAN HIGHLY ANGULAR CRUSHED NATIVE STONE
-20 PARTS: CLAY LOAM SOIL. CLAY LOAM SHALL CONFORM TO THE USDA SOIL CLASSIFICATION SYSTEM (GRAVEL <5%, SAND 25-30%, SILT 20-40%) ORGANIC MATTER SHOULD RANGE BETWEEN 2 AND 5%
 - SOIL MIX SHALL BE COMPACTED TO 95% MPR MIN. (MPR=MATERIAL'S MODIFIED PROCTOR - ASTM D1557 - MAX. DRY DENSITY) PER SPECIFICATIONS AND INSTALLED IN 6" LIFTS MAX.
 - INSTALL SEED MIX PER LANDSCAPE DRAWINGS AND INSTALL EXCELSIOR STRAW BLANKETS PER MANUFACTURER'S RECOMMENDATIONS.

E REINFORCED VEGETATED ROAD SHOULDER - DETAIL
SCALE: NTS

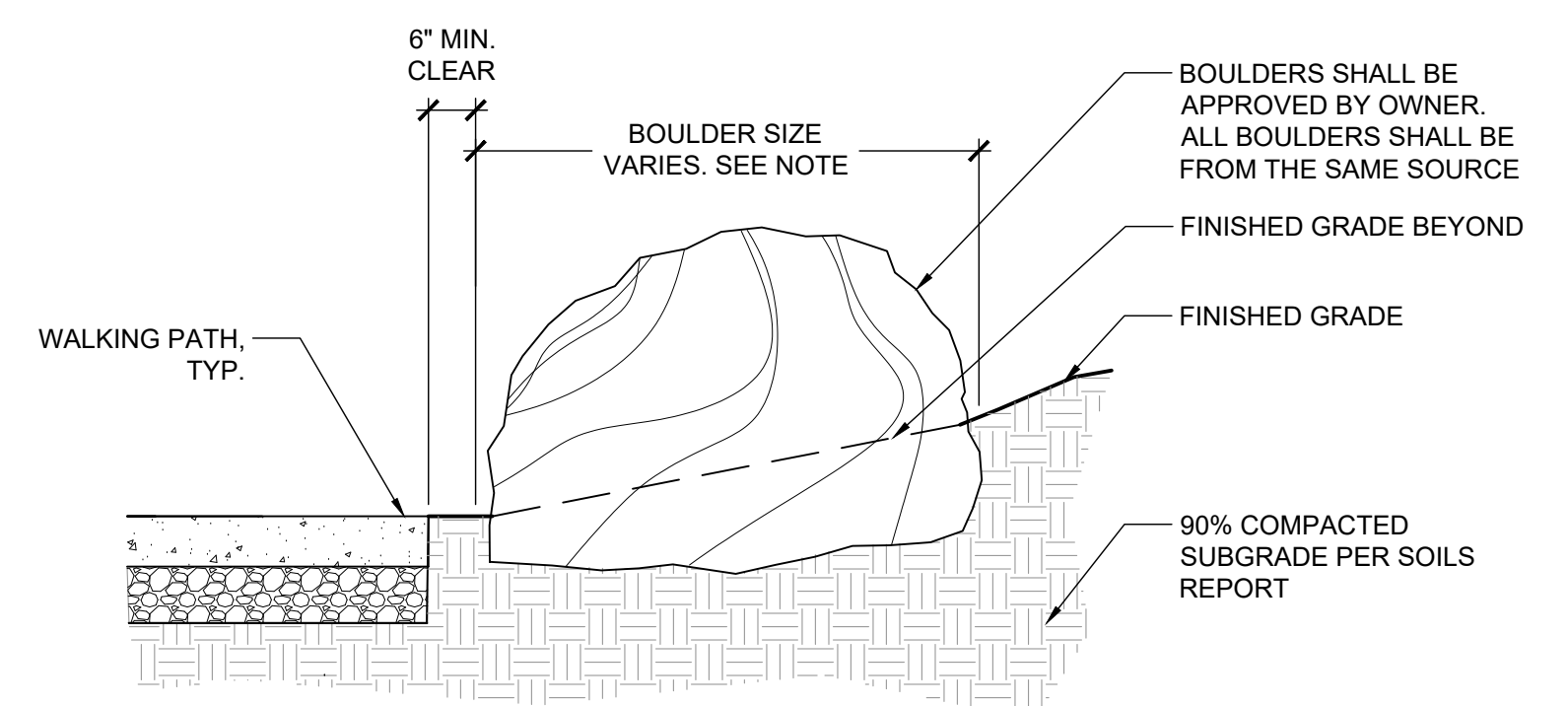

- NOTE:**
- BOULDERS TO BE WEATHERED, LOCALLY SOURCED OUTCROPPING ROCK WITH LICHEN, MOSS, &
 - INSTALL BOULDERS PER LANDSCAPE ARCHITECT DIRECTION AND SPECIFICATION.
 - BOULDER SIZES VARY:
30" L x 18" H x 2" W
36" L x 18" H x 2" W
5' L x 2' H x 30" W
7' L x 2' H x 3' W

G TYPICAL BOULDER PLACEMENT - DETAIL
SCALE: NTS

D NOT USED
SCALE: NTS

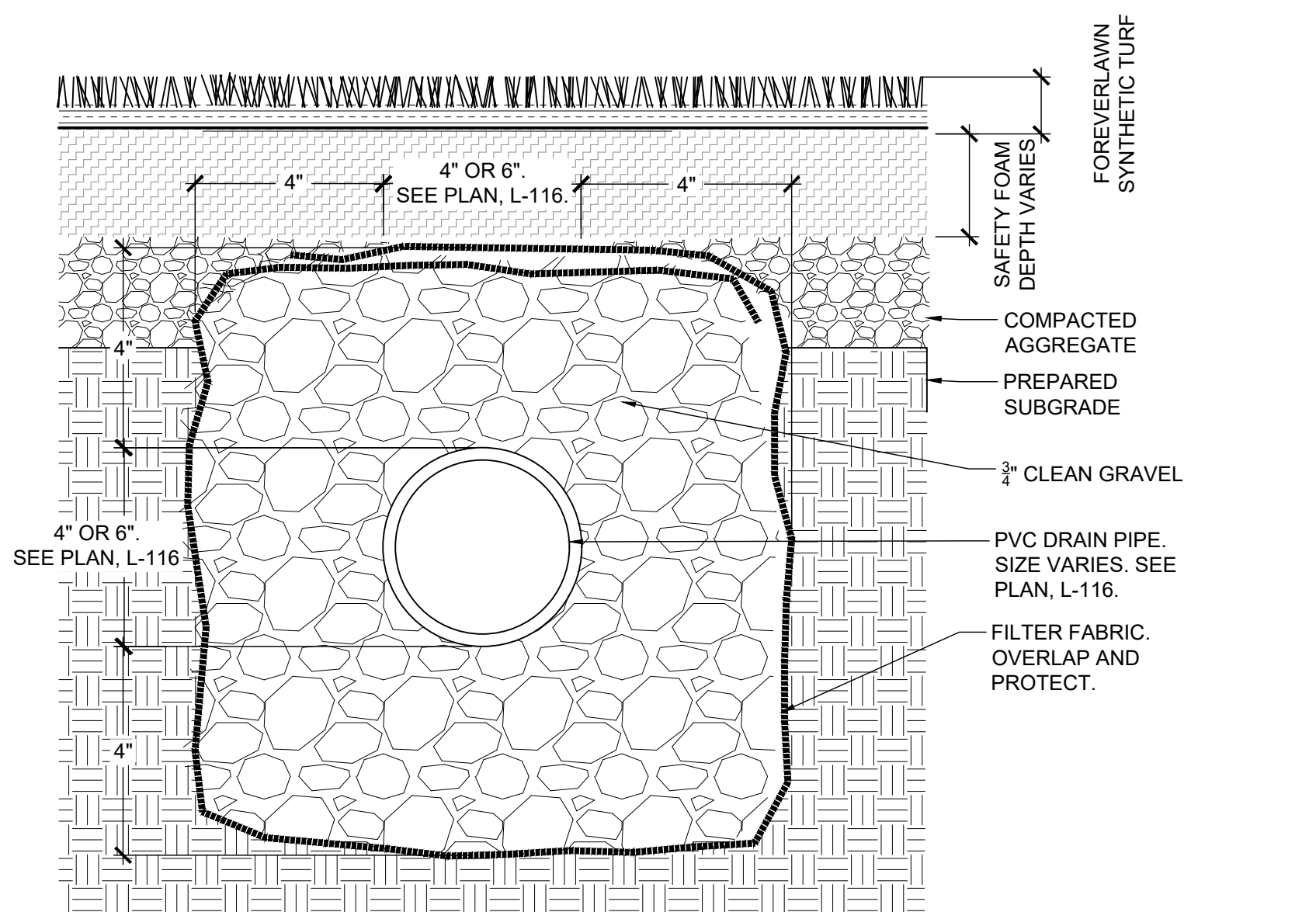

C PLAYGROUND UNDERDRAIN DETAIL
SCALE: NTS

F NOT USED
SCALE: NTS



NOTIFY LANDSCAPE ARCHITECT IMMEDIATELY IN EVENTS OF DISCREPANCIES, OMISSIONS, AND/OR CONFLICTS IN THE DRAWINGS OR SPECIFICATIONS. THE CONTRACTOR IS NOT AUTHORIZED TO SCALE THE DRAWINGS. ALL QUESTIONS IN REFERENCE TO CONTRACT DOCUMENTS SHALL BE IMMEDIATELY DIRECTED TO THE LANDSCAPE ARCHITECT.