

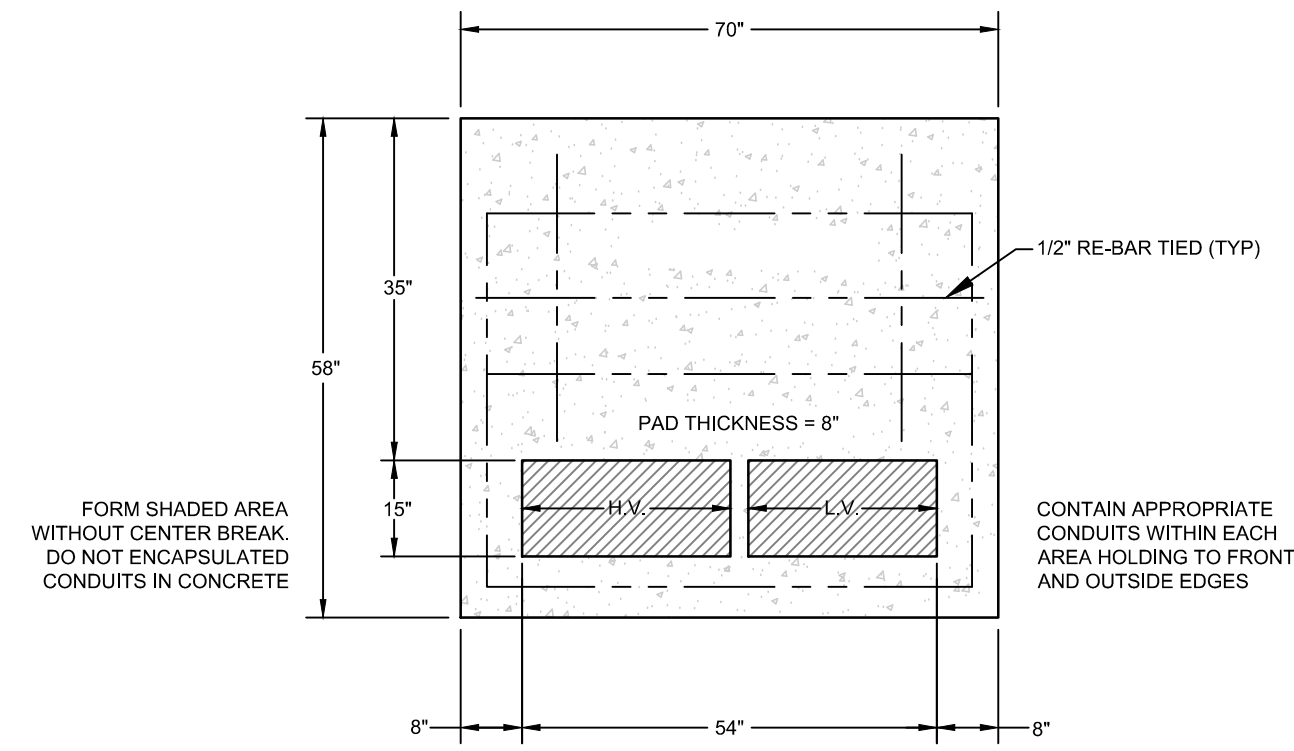

Issuances		
No.	Description	Date
01	PRICING SET	04/18/17
02	PRELIM P&Z	04/28/17
03	P&Z RESUBMIT	05/17/17
04	100% DD SET	05/31/17
05	50% CD SET	07/14/17
06	90% CD SET	08/01/17
07	PERMIT SET	08/18/17
08	PERMIT SET	09/22/17
09	PERMIT SET REVISIONS	10/04/17

Revisions		
No.	Description	Date



45-75 KVA TRANSFORMER PAD DETAIL
SCALE: N.T.S.

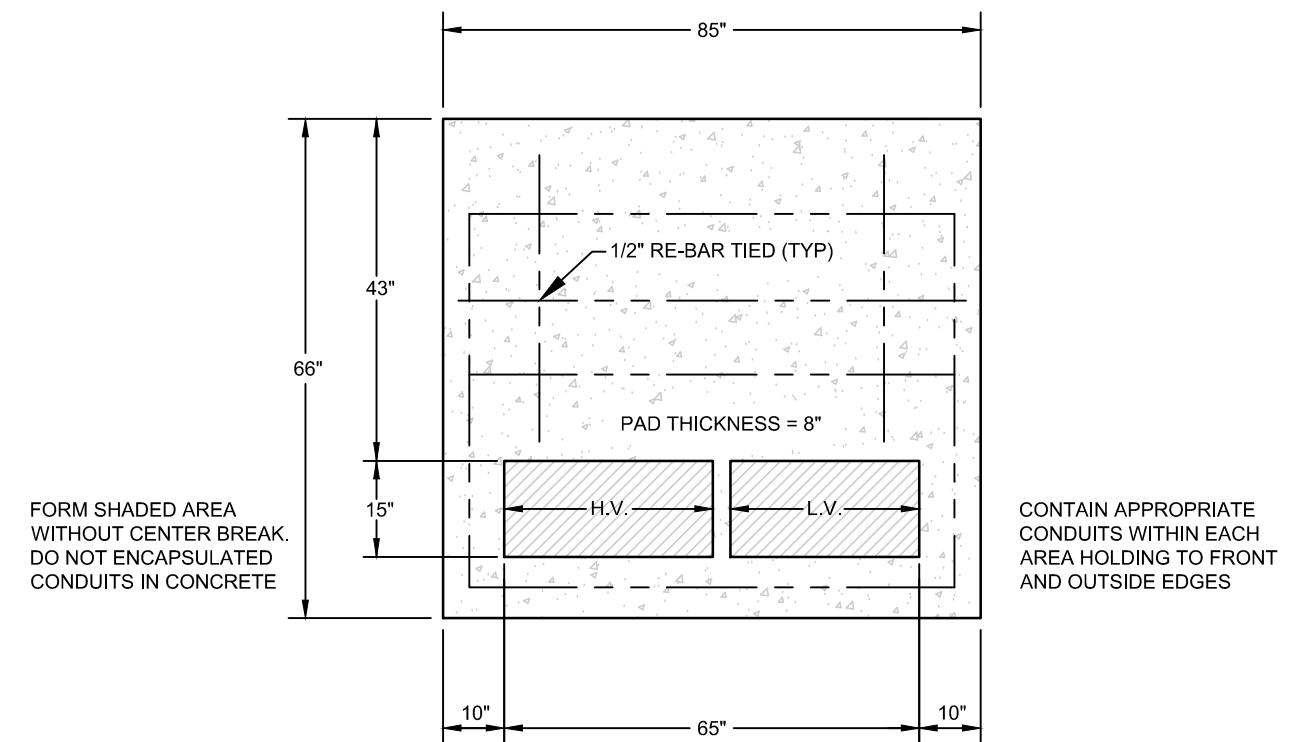

100-500 KVA TRANSFORMER PAD DETAIL
SCALE: N.T.S.

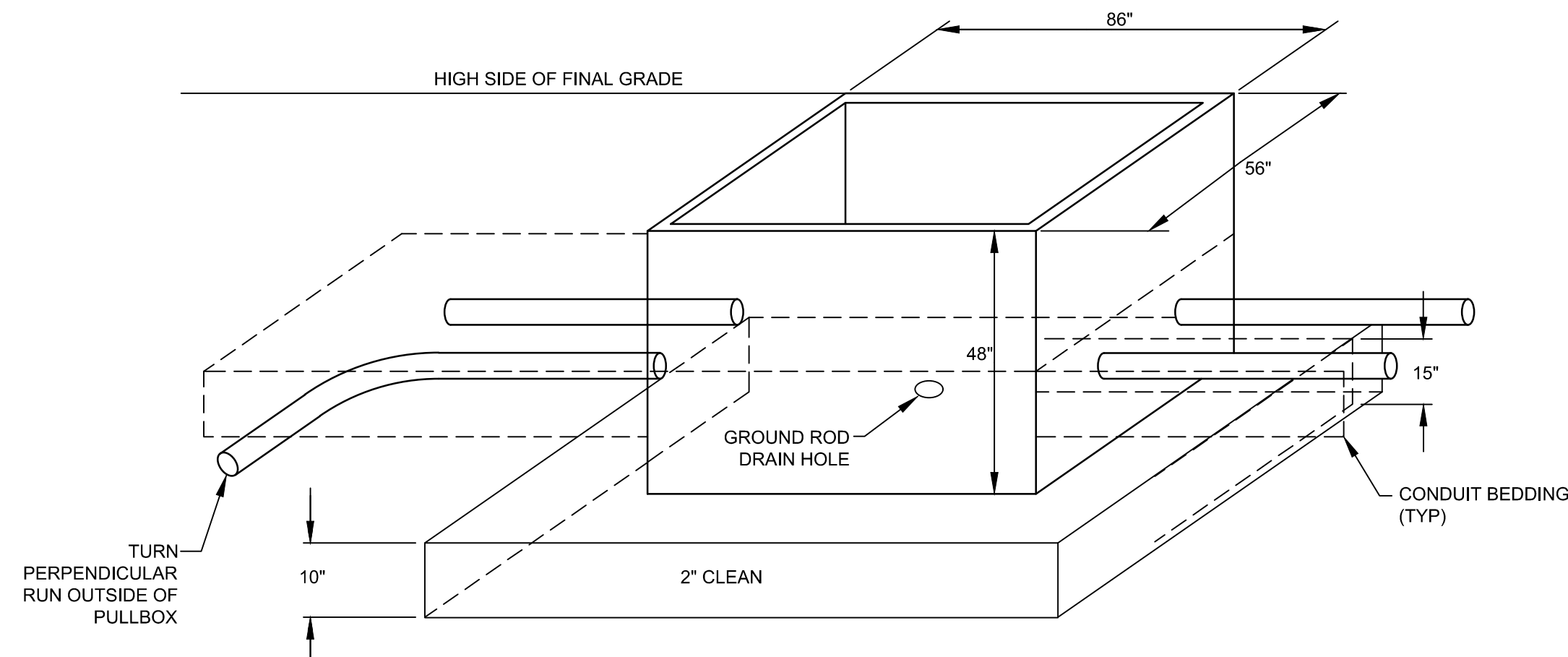

PULLBOX DETAIL
SCALE: N.T.S.

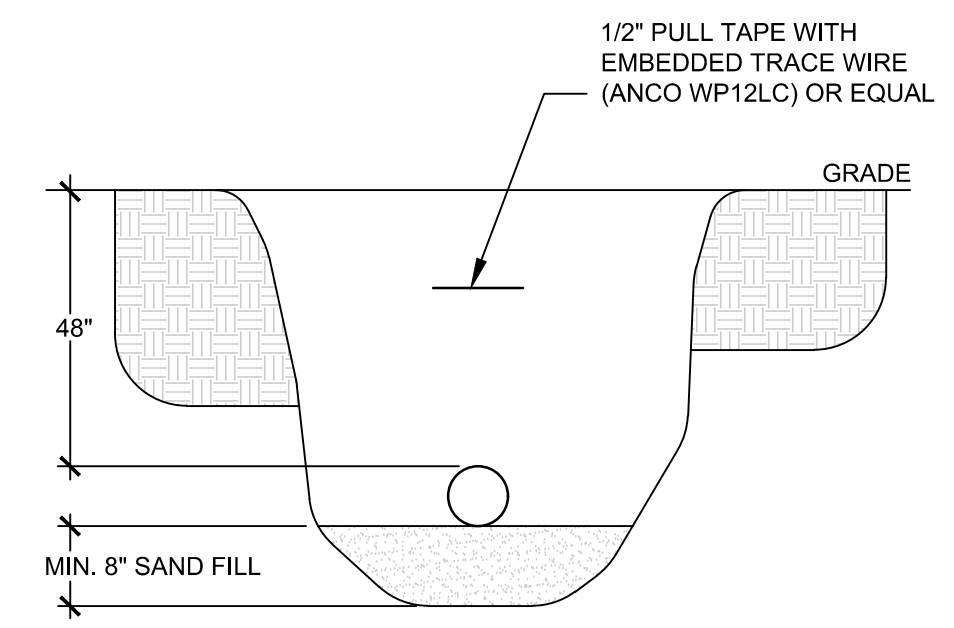

PRIMARY (UTILITY) CONDUIT BURIAL DETAIL
SCALE: N.T.S.

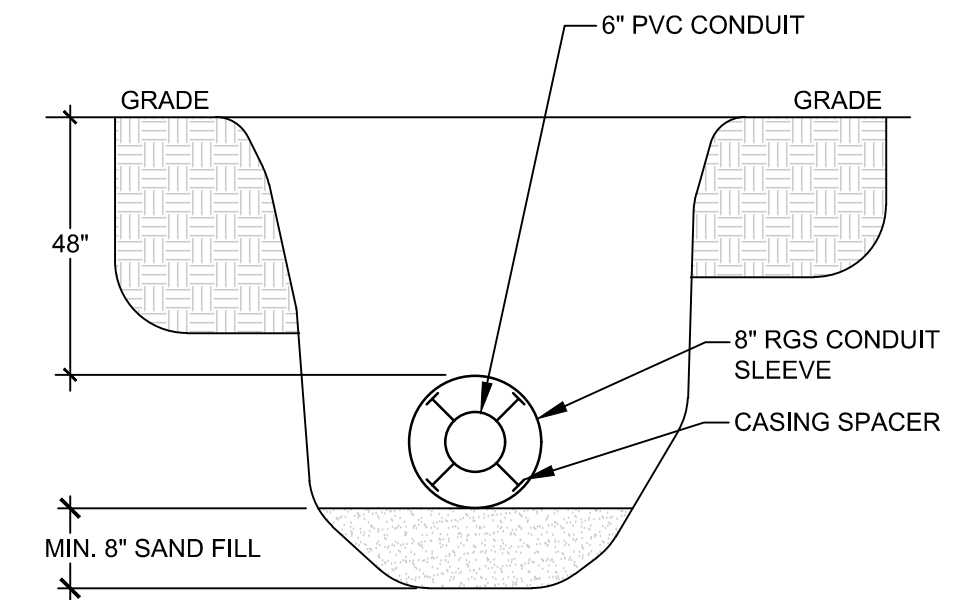

PRIMARY CONDUIT W / SLEEVE BURIAL DETAIL
SCALE: N.T.S.

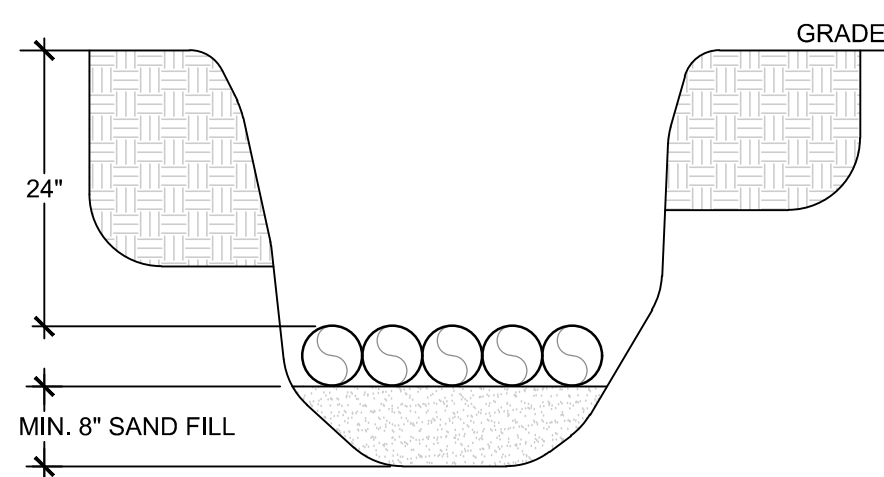

CONDUIT BURIAL DETAIL
SCALE: N.T.S.

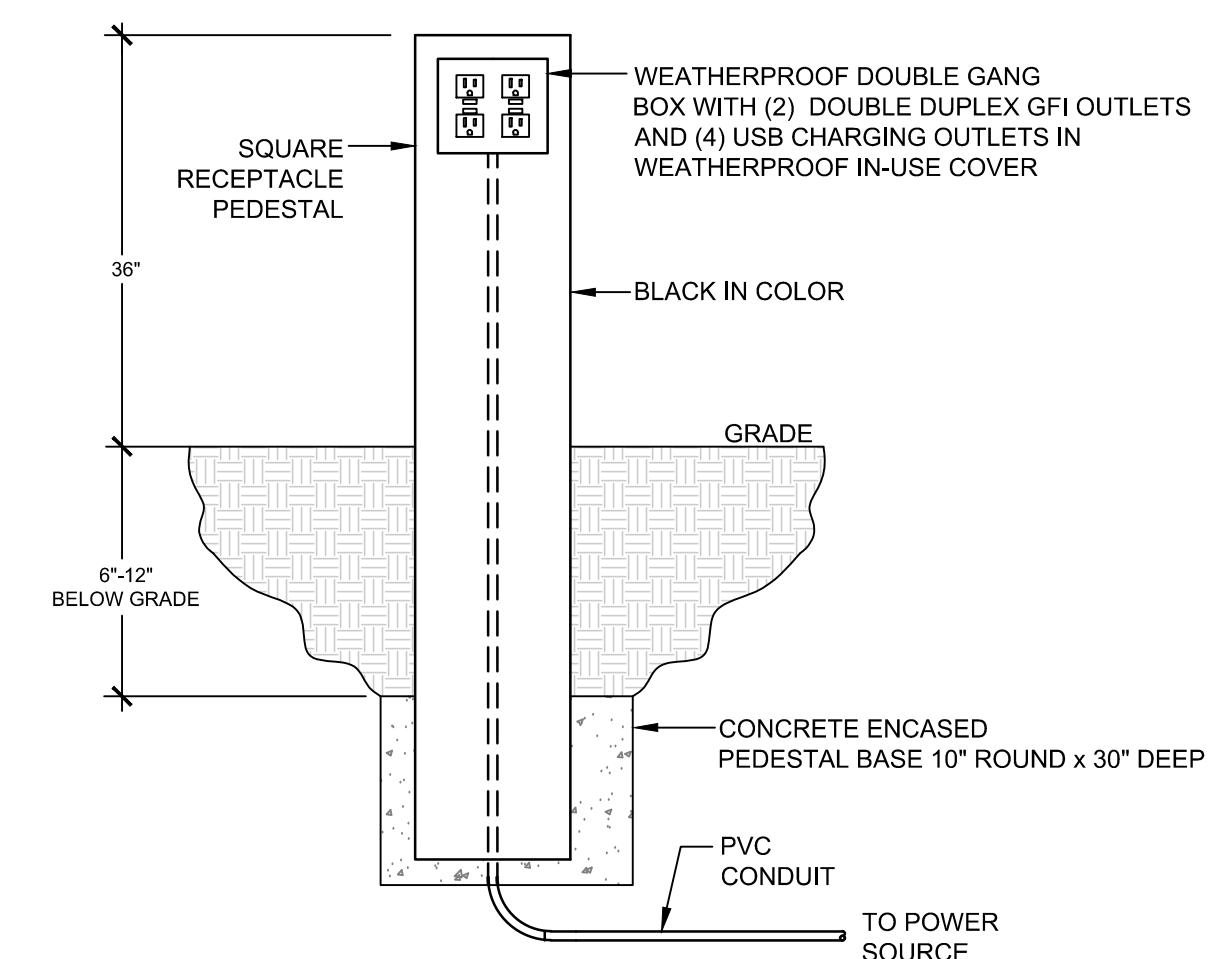

GROUND MOUNTED RECEPTACLE DETAIL
SCALE: N.T.S.