

TOP OF SAFETY BARRIER SHALL BE BUILT PARALLEL TO GRADE WITH SAFETY BARRIER JOINTS NORMAL TO GRADE.

ALL EXPOSED EDGES OF SAFETY BARRIER AND SIDEWALK SHALL HAVE EITHER A 1/2" RADIUS OR A 30° BEVEL UNLESS OTHERWISE NOTED.

WHEN THE SAFETY BARRIER IS BID BY LINEAR FOOT, THE CONTRACT UNIT PRICE SHALL INCLUDE THE COST OF ALL CONCRETE AND REINFORCEMENT, COMPLETE-IN-PLACE.

MEASUREMENT OF SAFETY BARRIER IS TO THE NEAREST LINEAR FOOT. IS MEASURED ALONG THE OUTSIDE TOP OF SLAB FROM END OF WING TO END OF WING.

PLAN VIEWS OF SIDEWALK SHOWING REINFORCEMENT

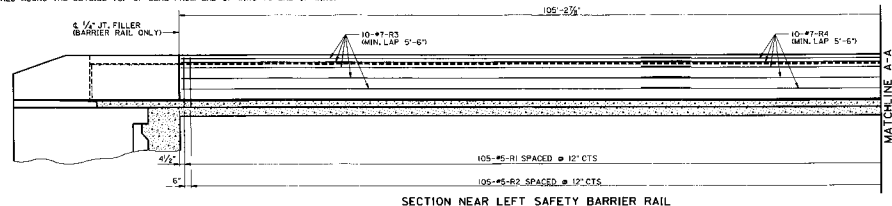

SECTION NEAR LEFT SAFETY BARRIER RAIL

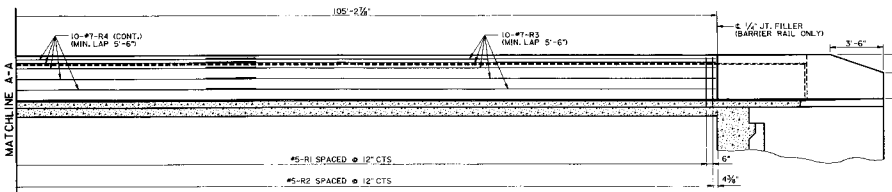

SECTION NEAR LEFT SAFETY BARRIER RAIL



V-GROOVE DETAIL

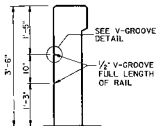

RAIL RUSTIFICATION DETAIL

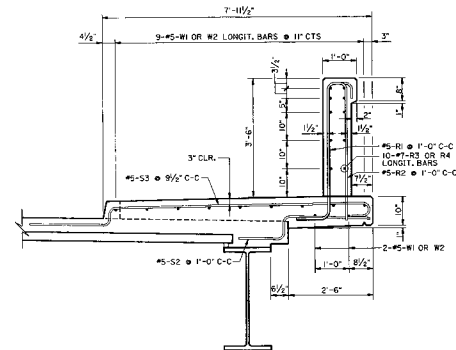

CONCRETE PARAPET AND SIDEWALK DETAILS

WHEN THE SIDEWALK IS BID BY SQ. FOOT, THE CONTRACT UNIT PRICE SHALL INCLUDE THE COST OF ALL CONCRETE AND REINFORCEMENT, COMPLETE IN PLACE.

CONCRETE IN THE SIDEWALK SHALL BE CLASS B-2.

MEASUREMENT OF THE SIDEWALK IS TO THE NEAREST SQUARE FOOT, MEASURED HORIZONTALLY FROM THE FACE OF CURB TO THE OUTSIDE EDGE OF THE STRUCTURE AND FROM END OF WINGWALL TO END OF WINGWALL.

TRANSVERSE SIDEWALK REINFORCING STEEL TO BE PLACED PARALLEL SKEW.

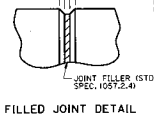

FILLED JOINT DETAIL

SIDEWALK AND RAIL DETAILS
1 OF 2

DATE	01/11/2007
PROJECT	O'FALLON ROAD
BY	W. W. GARDNER
CHECKED	
DATE	

DATE	01/11/2007
PROJECT	O'FALLON ROAD
BY	W. W. GARDNER
CHECKED	
DATE	

DATE	01/11/2007
PROJECT	O'FALLON ROAD
BY	W. W. GARDNER
CHECKED	
DATE	