

	ROW Width	Pavement Width	Lane Width	No. of Drive Lanes	Utility Easement	Design Speed
Minor Arterial	84	60	12	5	10	40
Collector	60	39	12	3	10	35
Residential Collector	56	32**	N/A	2	10	25
Minor Residential Local Access	50	26	N/A	2	10	25*

Notes: * = Can be varied with City Engineer's approval
 ** = Detail to match minor residential street with wider pavement
 - these requirements may be varied by other City ordinances
 - these standards are minimum standards
 - Parkway options can be provided as indicated above

Designer will provide roadway cross section and joint locations in a separate detail drawing.

CITY OF O'FALLON
 ENGINEERING DEPARTMENT
 O'FALLON, MISSOURI

Typical Pavement Design
 SECTION NO. 405.970

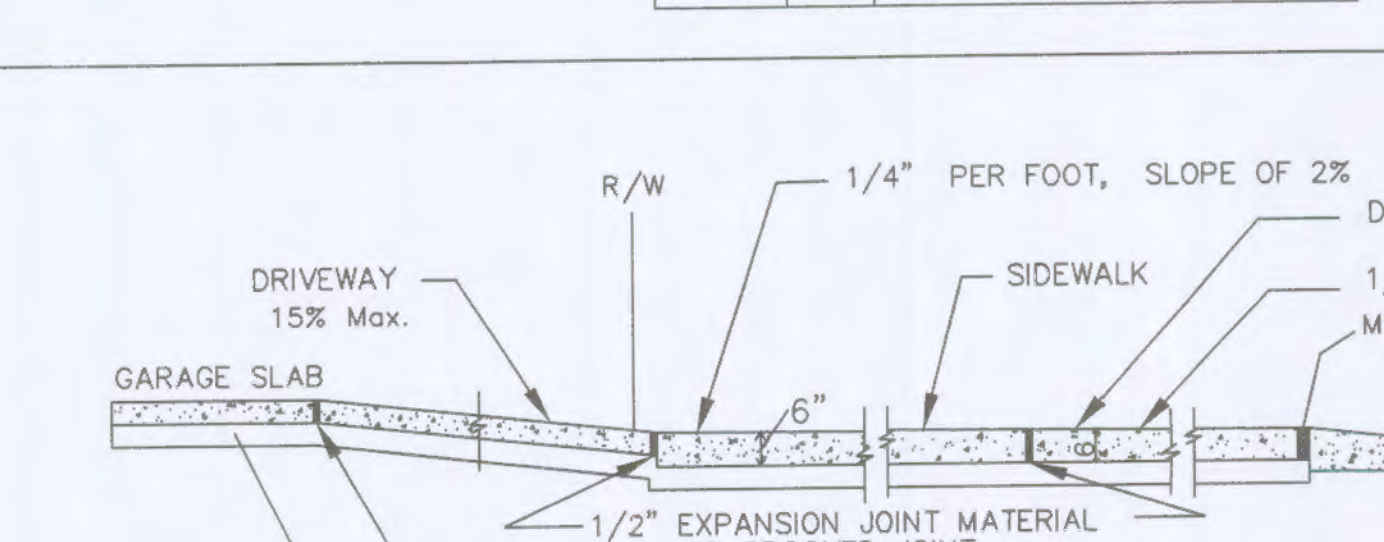
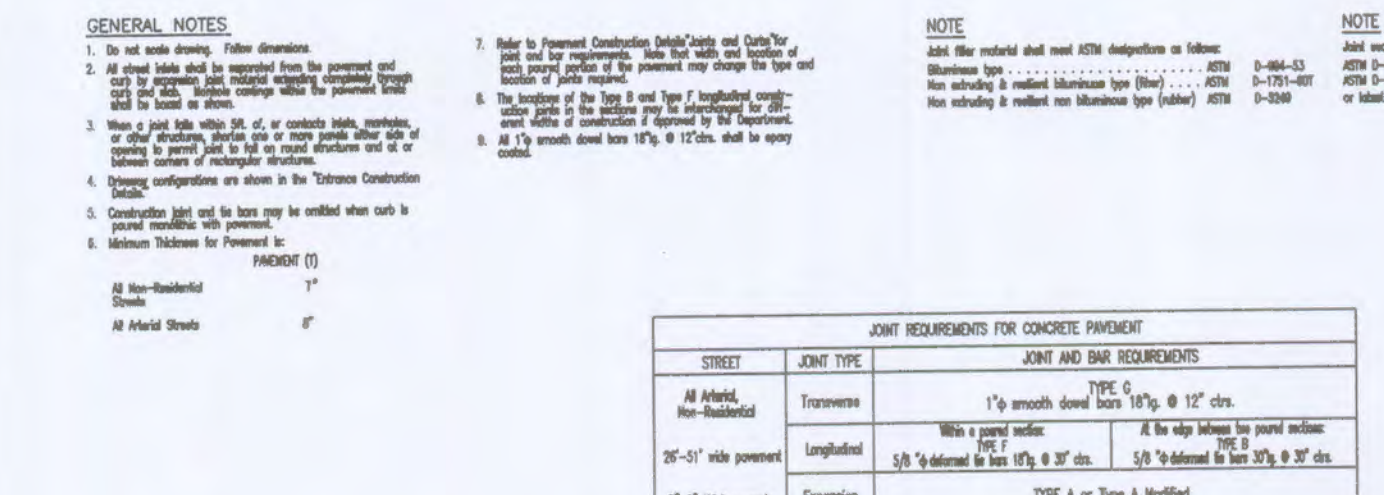
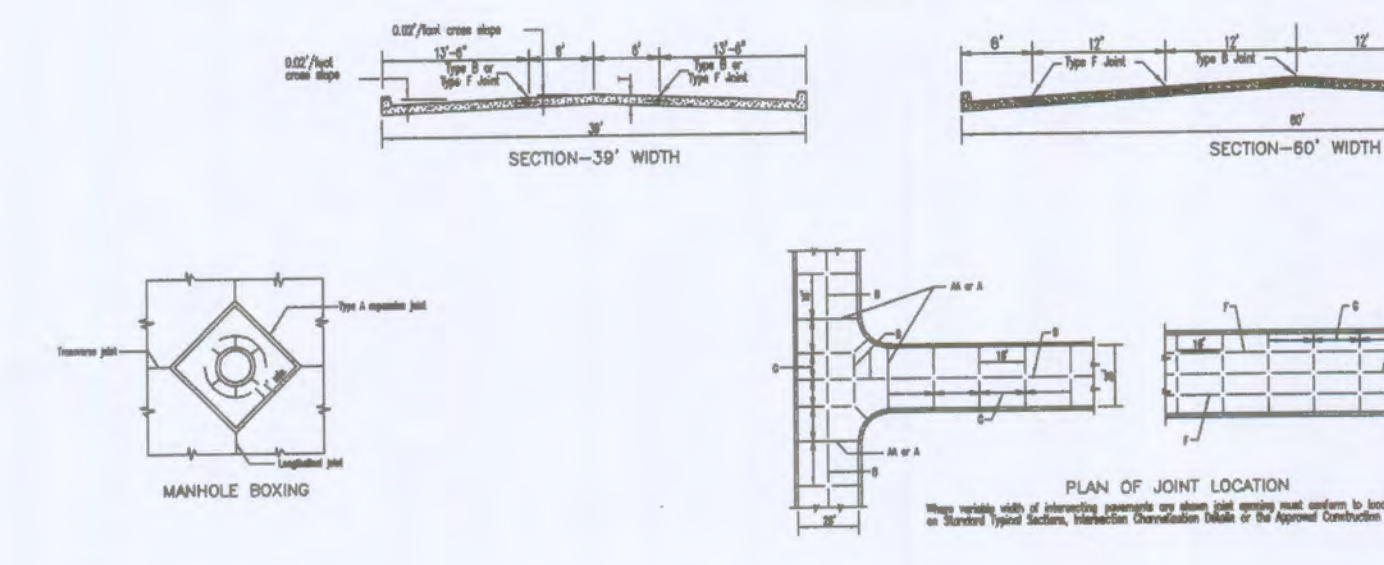
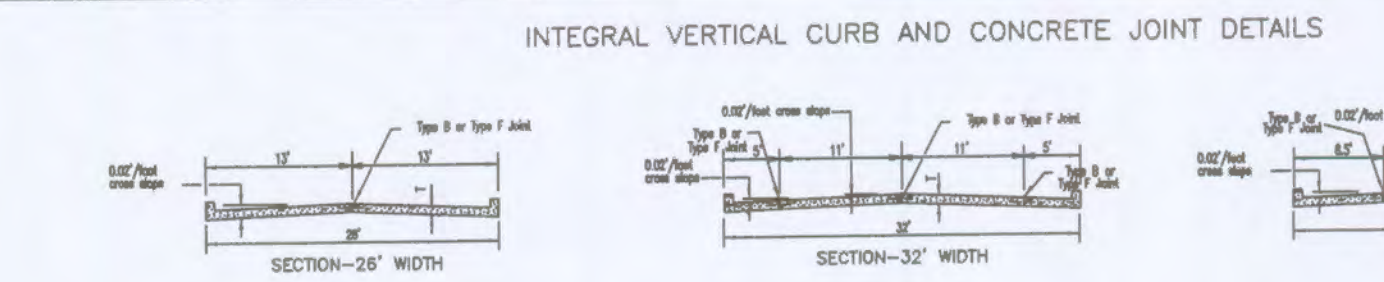
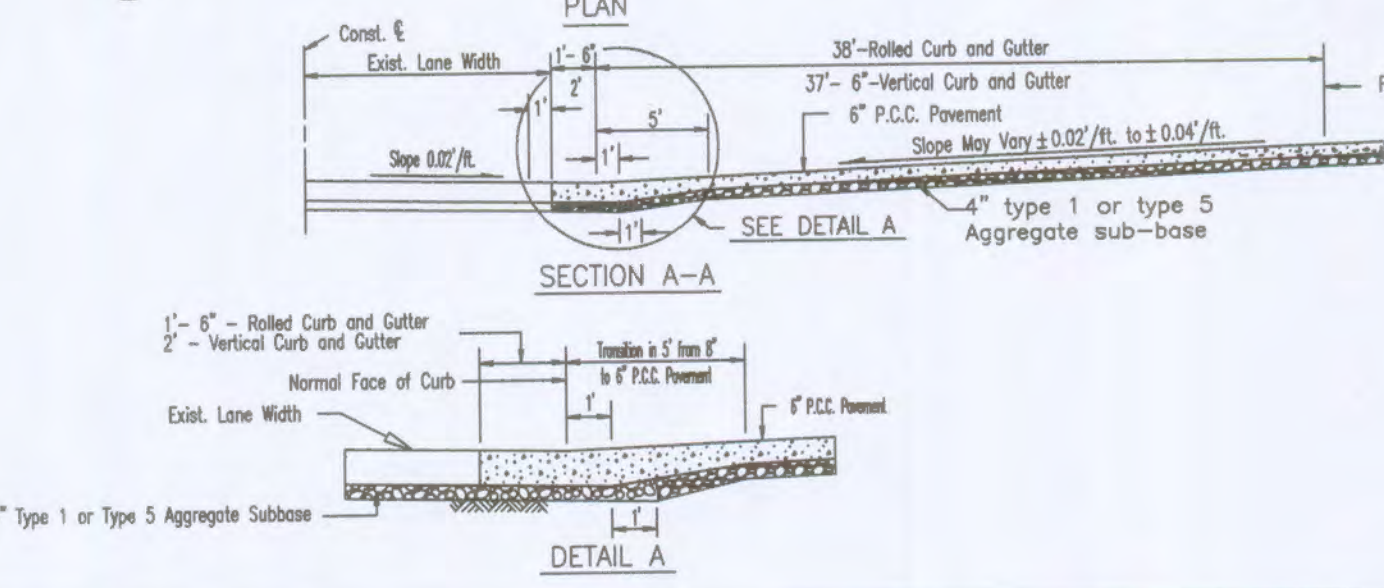
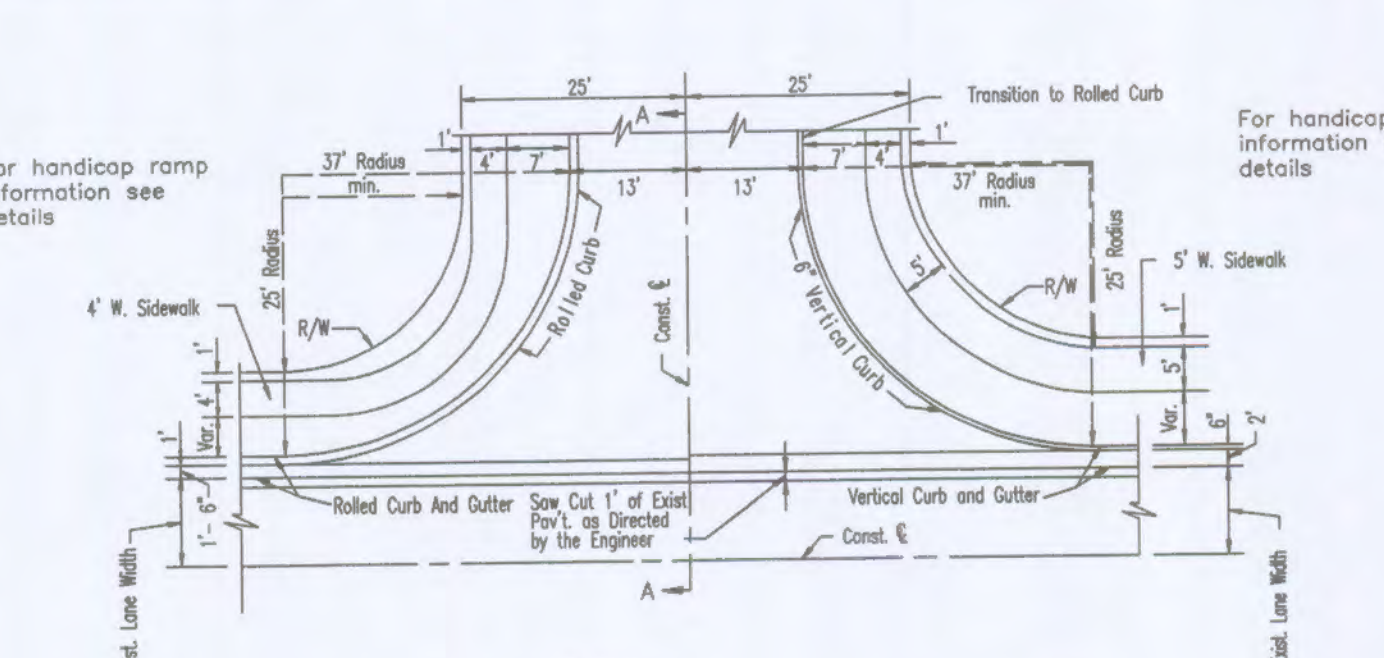

GENERAL NOTES

- Do not scale drawing. Follow dimensions.
- Sections are symmetrical about construction centerline.
- For longitudinal and transverse joints, dowel and bar requirements and curb dimensions refer to the Pavement Construction Details for Joints and Curbs.
- All necessary pavement markings shall be as required by City of O'Fallon.
- For roadway cross slopes, pavement types and thickness refer to Standard Typical Sections.

CITY OF O'FALLON
 ENGINEERING DEPARTMENT
 O'FALLON, MISSOURI

PAVEMENT CONSTRUCTION DETAILS
 STANDARD RESIDENTIAL
 STREET ENTRANCE

Integral Curb Detail
 "B" at Driveway
 SECTION NO. 505.080

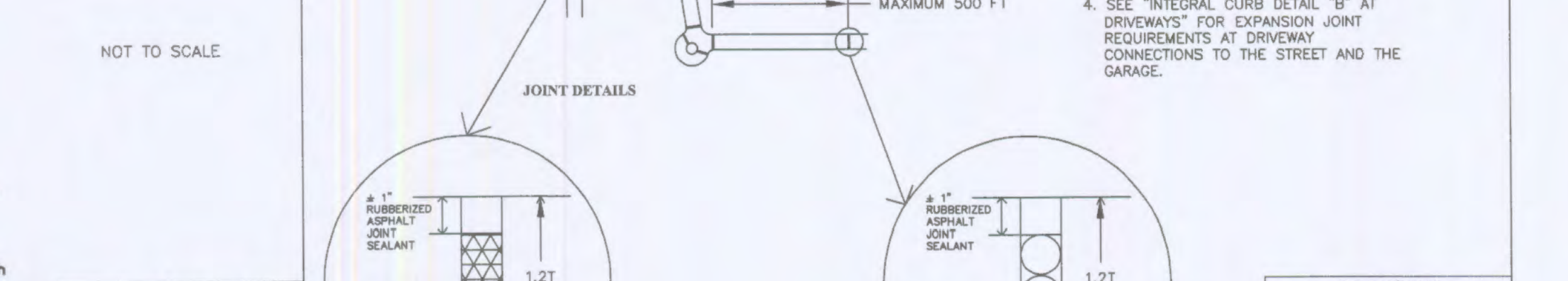
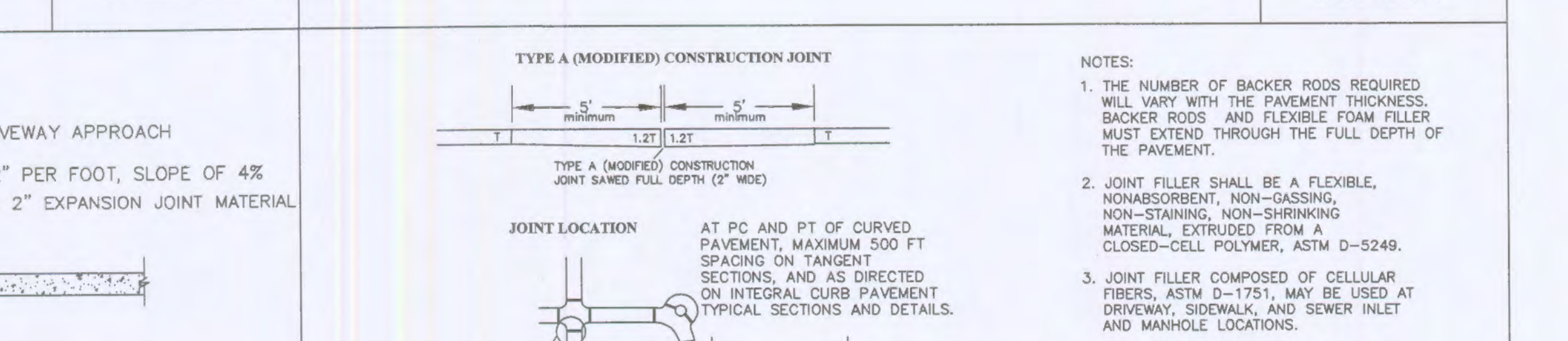
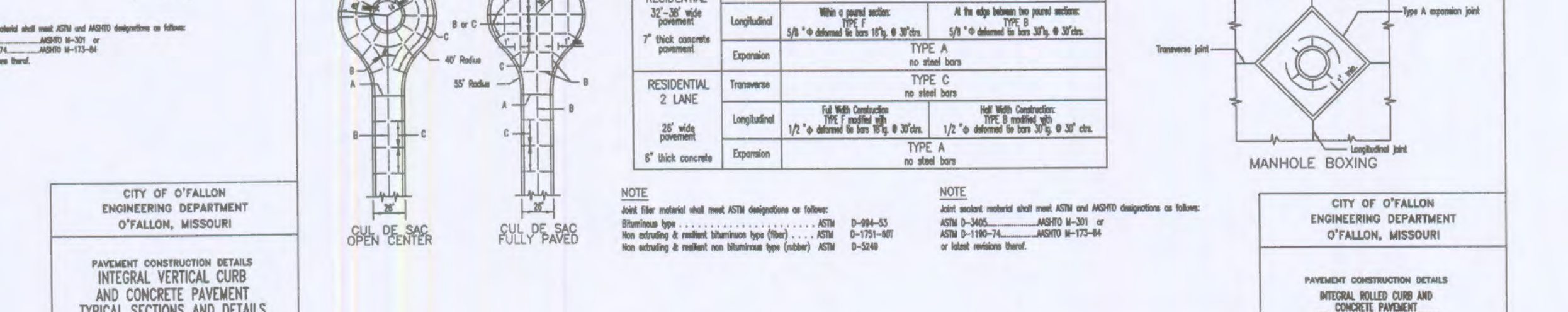
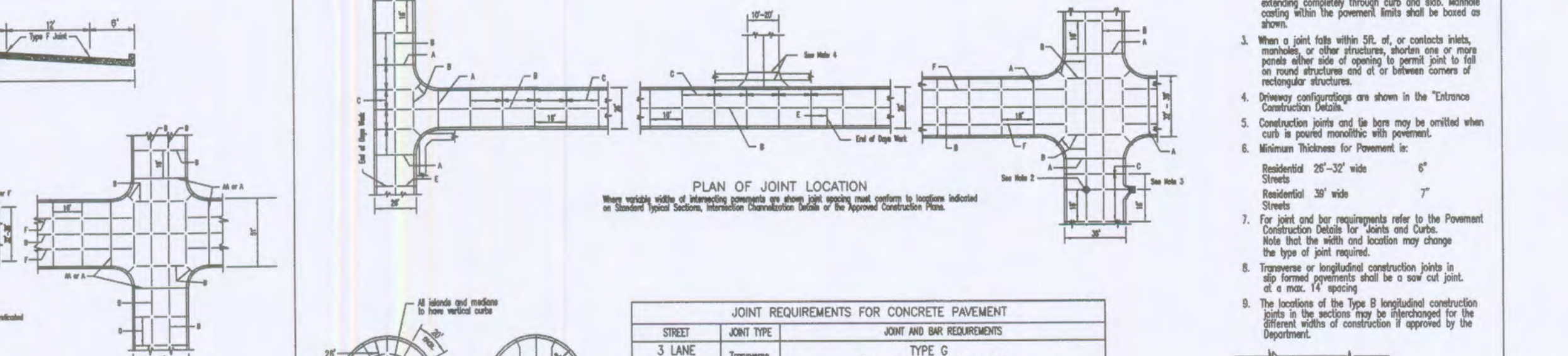
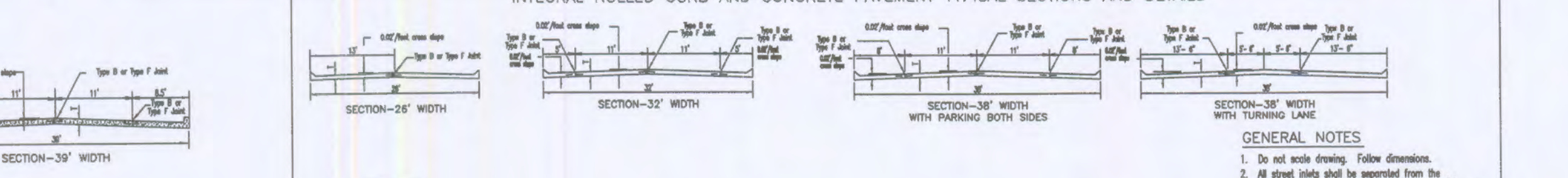
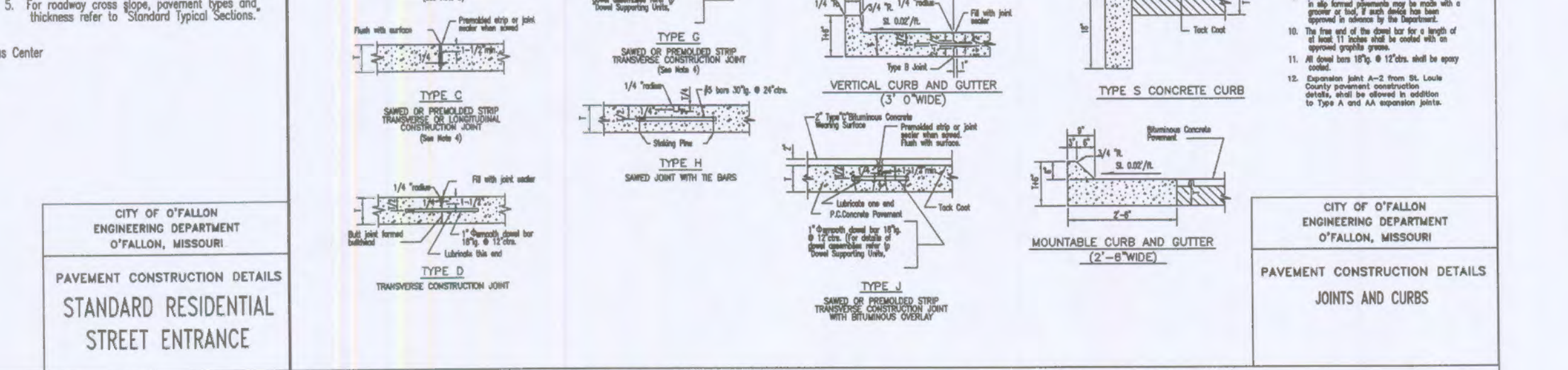
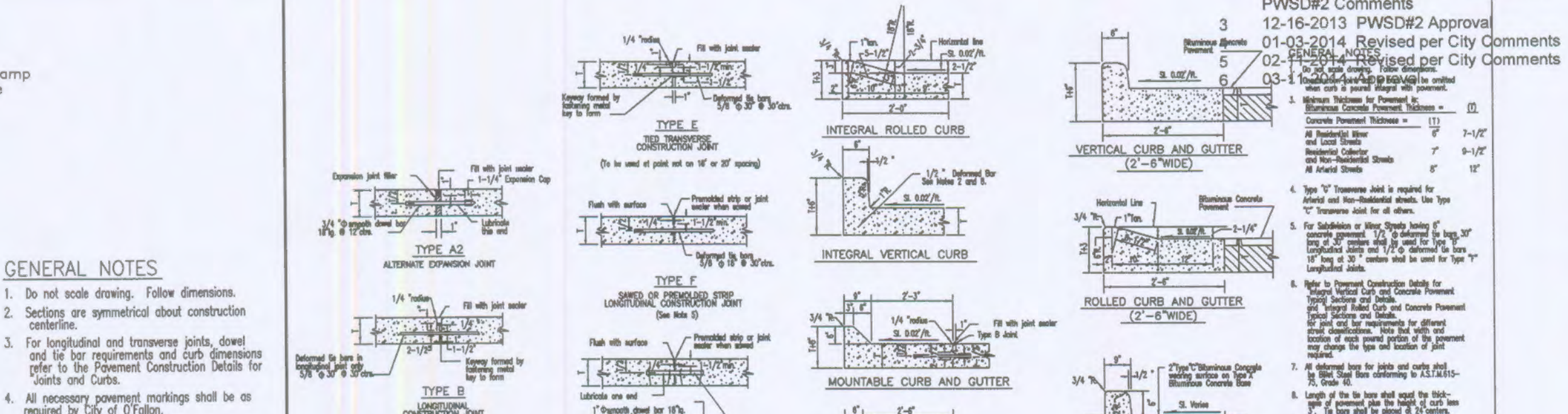

CITY OF O'FALLON
 ENGINEERING DEPARTMENT
 O'FALLON, MISSOURI

PAVEMENT CONSTRUCTION DETAILS
 INTEGRAL VERTICAL CURB
 AND CONCRETE PAVEMENT
 TYPICAL SECTIONS AND DETAILS

PAVEMENT CONSTRUCTION
 DETAIL

PROJECT TITLE

OAKHURST
 O'FALLON, MISSOURI

THE STERLING CO.
 ENGINEERS & SURVEYORS
 5055 New Baumgartner Road
 St. Louis, Missouri 63129
 Ph 314-487-0440 Fax 314-487-8944
 www.sterling-eng-sur.com
 Corporate Certificate of Authority #001348

CITY OF O'FALLON
 ENGINEERING DEPARTMENT
 O'FALLON, MISSOURI

PAVEMENT CONSTRUCTION DETAILS
 JOINTS AND CURBS

GENERAL NOTES

- Do not scale drawing. Follow dimensions.
- All detail shall be as shown on this drawing and shall be constructed in accordance with the specifications and standards of the Missouri Department of Transportation (MoDOT) and the City of O'Fallon.
- When a joint falls within 5% of a concrete slab, it shall be a construction joint. The location of the joint shall be indicated on the drawing.
- Driveway configurations are shown in the "Driveway" section of this drawing.
- Construction joints and tie bars may be omitted when not required by the specifications.
- Minimum Thickness for Pavement is:
 Residential 2" wide Street 4"
 Residential 3" wide Street 7"
- For joint and bar requirements refer to the Pavement Construction Details for Joints and Curbs. Note that the width and location may change the type of joint required.
- Transverse or longitudinal construction joints in concrete shall be a saw cut joint, at a max. 1' spacing.
- The location of the Type B longitudinal construction joint in the driveway may be determined by the different methods of construction approved by the City Engineer.

Date: Michael G. Boarding
 License No. MO E-28643
 Civil Engineer

LOMBARDO HOMES
 2299 Technology Drive
 O'Fallon, Missouri 63368
 Ph. 636-265-2710

PAVEMENT DETAILS

P+Z No. 207.02
 City No.
 Date: July 22, 2013
 Job No. 12-10-284
 Page No.

DTL-13
 IMP