

MULCH SEDIMENT BARRIER
NOT TO SCALE

NOTE: CONTRACTOR TO USE MULCH FROM ONSITE CLEARING OPERATIONS WHEN POSSIBLE.

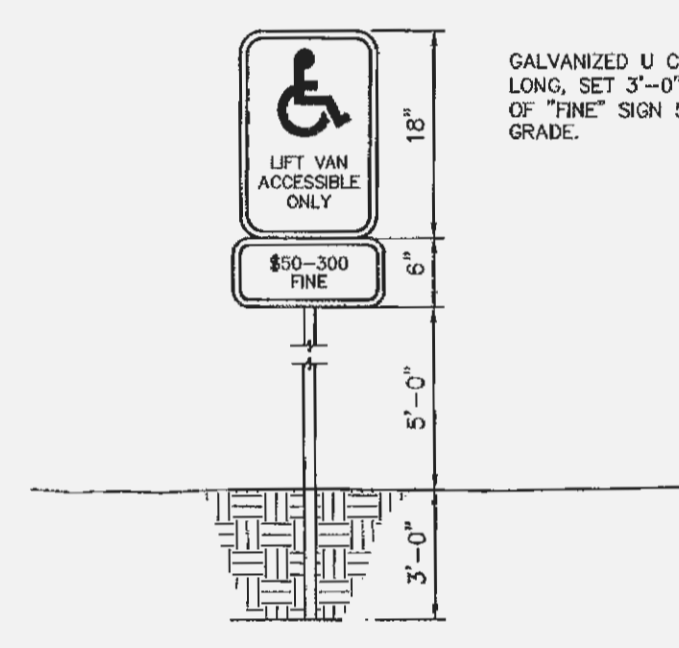

LIFT VAN ACCESSIBLE ONLY PARKING SIGN
NOT TO SCALE

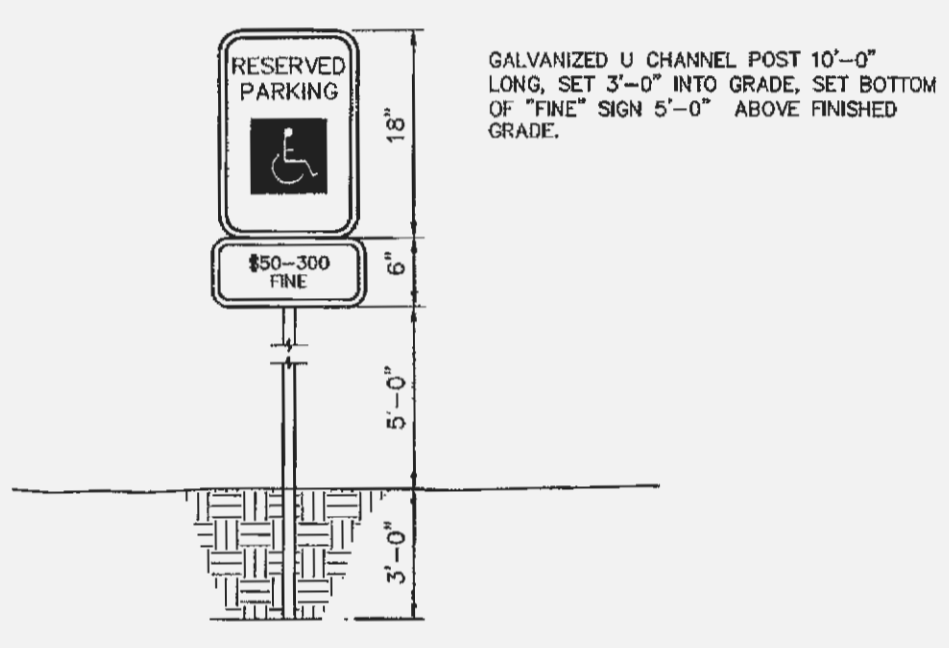

ACCESSIBLE VEHICLE PARKING SIGN
NOT TO SCALE

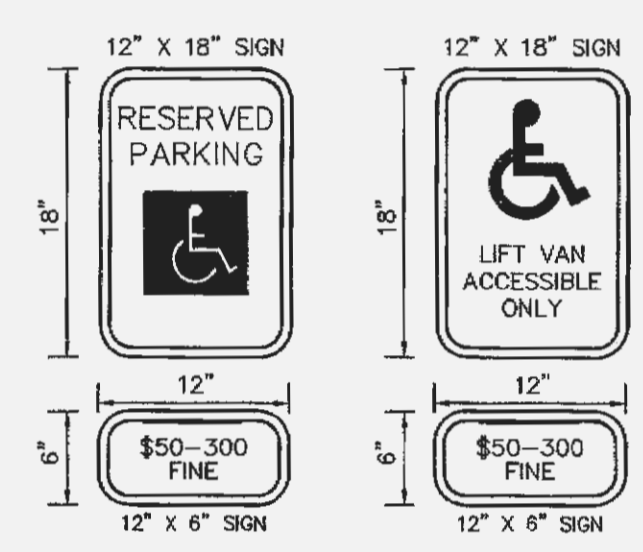

ACCESSIBLE PARKING SIGNS
NOT TO SCALE

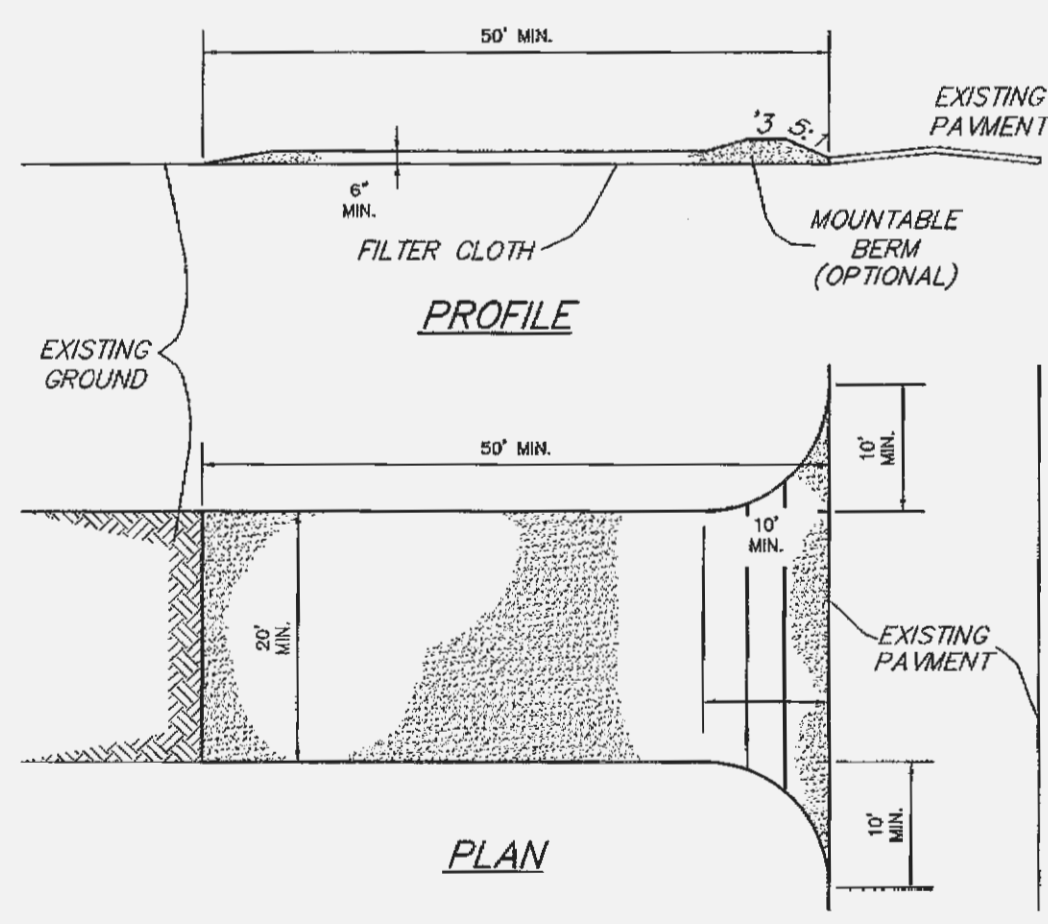

CONSTRUCTION SPECIFICATIONS

1. Stone Size - Use 2" stone, or reclaimed or recycled concrete equivalent.
2. Length - As required, but not less than 50 feet (except on a single residence lot where a 30 foot minimum length would apply).
3. Thickness - Not less than six (6) inches.
4. Width - Twenty (20) foot minimum, but not less than the full width at points where ingress or egress occurs.
5. Filter Cloth - Will be placed over the entire area prior to placing of stone. Filter will not be required on a single family residence lot.
6. Surface Water - All surface water flowing or diverted toward construction entrances shall be piped across the entrance. If piping is impractical, a mountable berm with 5:1 slopes will be permitted.
7. Maintenance - The entrance shall be maintained in a condition which will prevent tracking or flowing of sediment onto public rights-of-way. This may require periodic top dressing with additional stone as conditions demand and repair and/or cleanout of any measures used to trap sediment. All sediment spilled, dropped, washed or tracked onto public rights-of-way must be removed immediately.
8. Washing - Wheels shall be cleaned to remove sediment prior to entrance onto public rights-of-way. When washing is required, it shall be done on an area stabilized with stone and which drains into an approved sediment trapping device.
9. Periodic inspection and needed maintenance shall be provided after each rain.

STABILIZED CONSTRUCTION ENTRANCE/WASHDOWN AREA
NOT TO SCALE

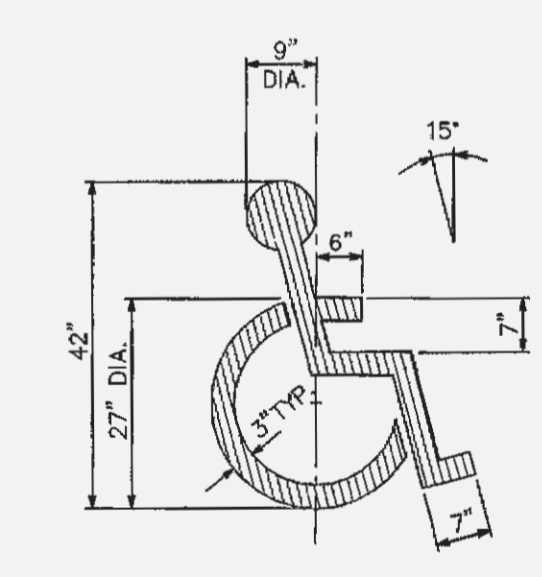

PAINTED ACCESSIBLE PARKING SYMBOL
NOT TO SCALE

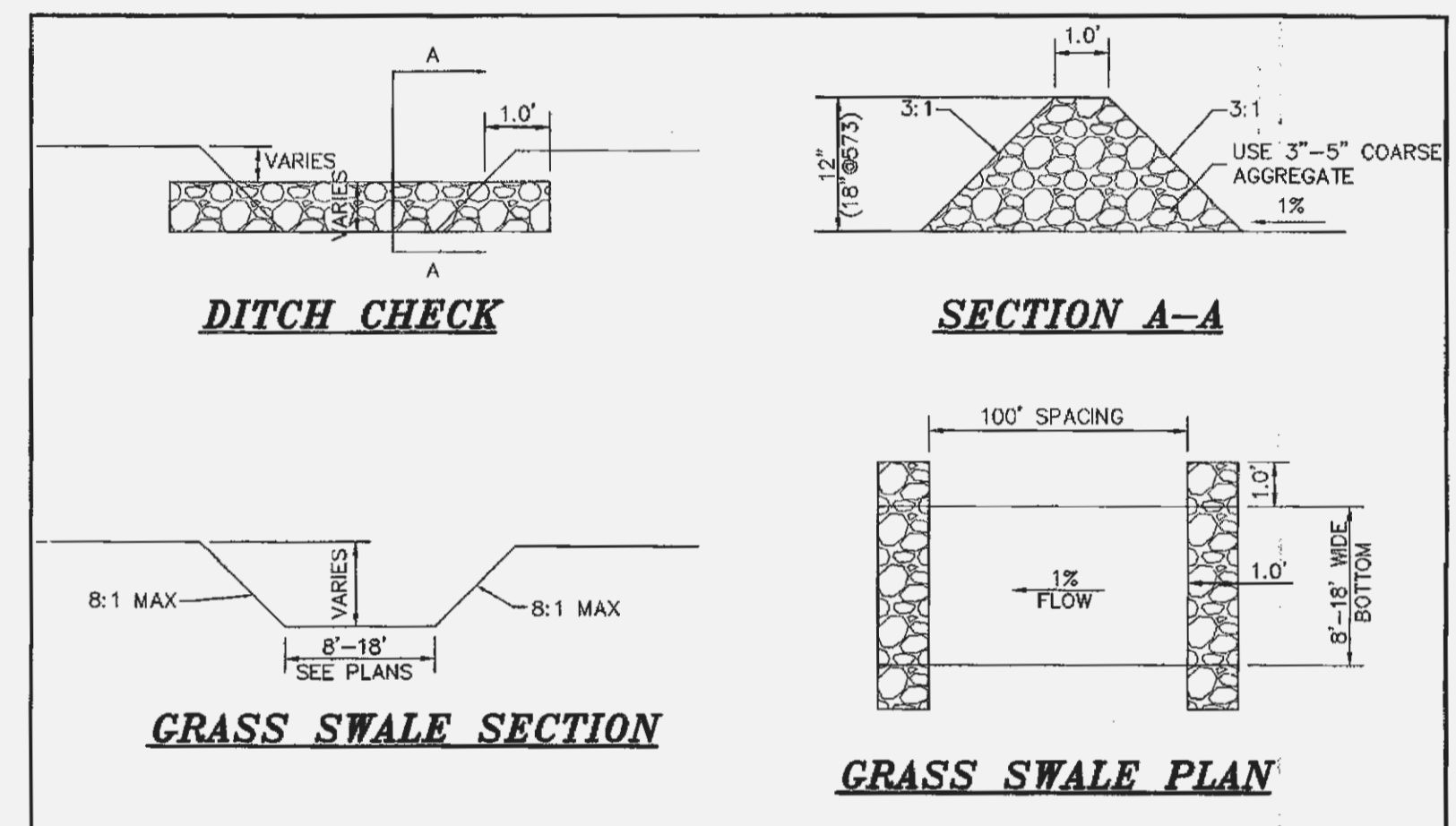

GRASS SWALE NOTES

1. A dense cover of water-tolerant, erosion-resistant grass or other vegetation must be established using either sod or seeding with erosion control matting.
2. Recommended grasses include, but are not limited to the following: Kentucky-31 tall fescue, reed canary grass, redtop and rough-stalked blue grass. Note that these grasses can be mixed.
3. Maintain a minimum of 6" grass height or greater in swale.
4. Construction standards and specifications should comply with the City of O'Fallon Standards.
5. Swale should initially be excavated to within 6" of finish grade. Final grade excavation shall be deferred until all disturbed areas in the watershed have been stabilized. Final excavation shall remove all accumulated sediment.
6. When final grading is completed, the swale bottom should be tilled with rotary tillers or disc harrows to provide a well aerated surface.
7. Soils for swale area should consist of: SL, ML, SM, or SC type materials.

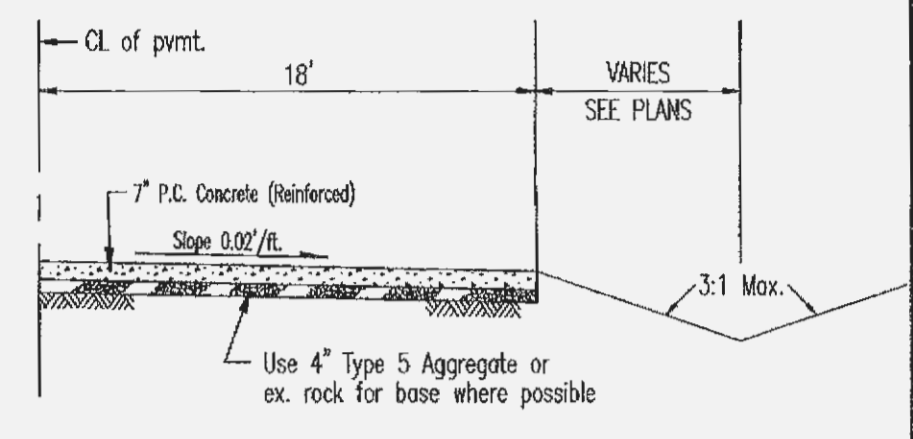

ROAD SECTION W/NO CURB

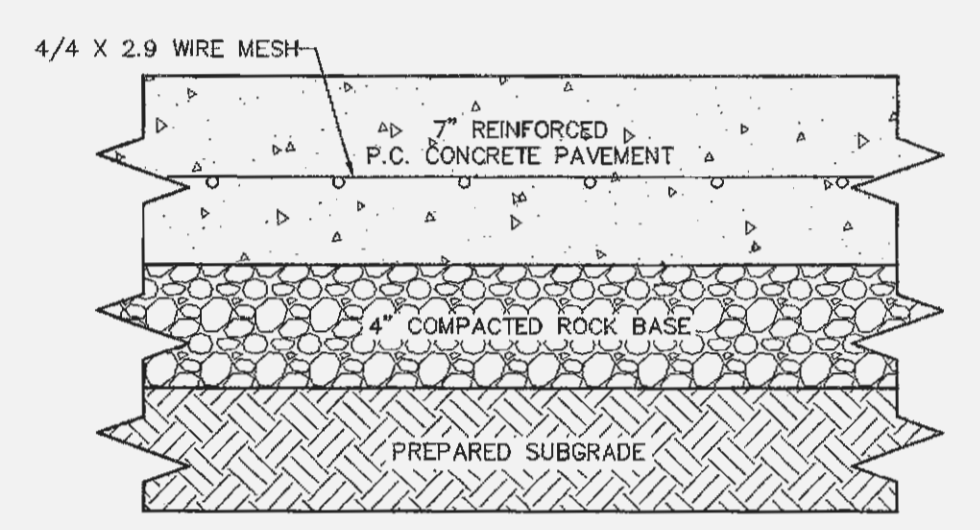

ONSITE PAVEMENT DETAIL
NOT TO SCALE

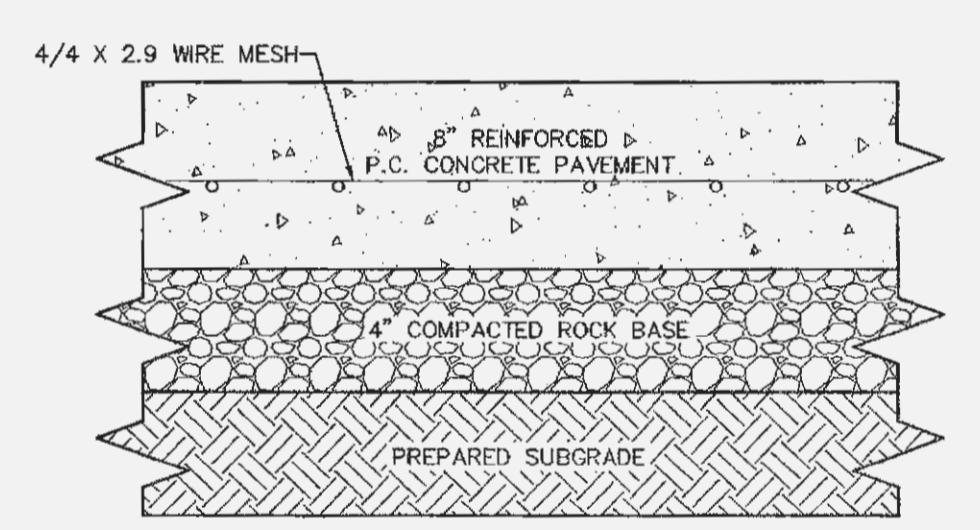

HOFF ROAD R/W PAVEMENT DETAIL
NOT TO SCALE

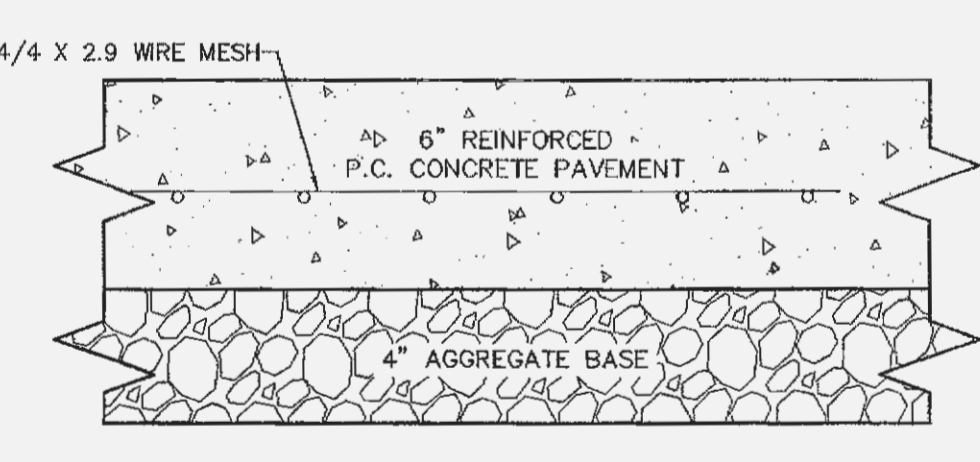

PARKING LOT PAVEMENT DETAIL
NOT TO SCALE

- NOTE:
1. ALL PAVEMENT TO BE REINFORCED WITH 4/4 X 2.9 WIRE MESH.
 2. USE EXISTING ROADWAY AS ROCK BASE FOR PRIVATE DRIVE WHERE POSSIBLE.
 3. ALL GRANULAR ROLLED STONE BASE UNDER PROPOSED CONCRETE MUST BE COMPACTED TO 100% OF THE MAXIMUM DENSITY AS DETERMINED BY THE STANDARD PROCTOR TEST AASHTO-99.
 4. CONCRETE COMPRESSIVE STRENGTH SHALL BE 4000 PSI IN 28 DAYS.

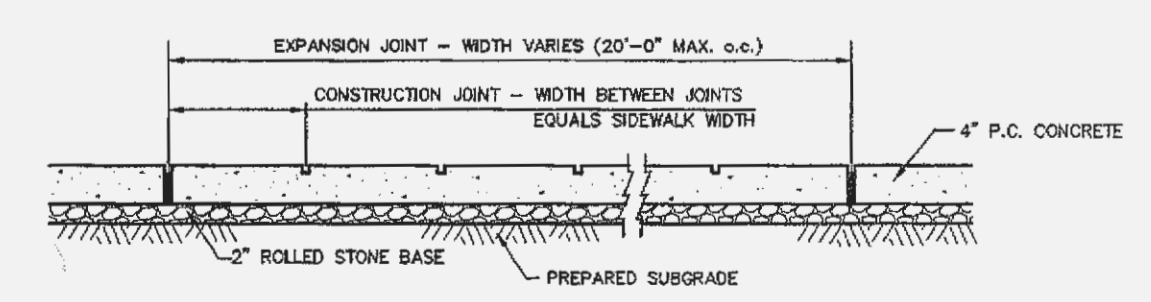

CONCRETE SIDEWALK DETAIL
NOT TO SCALE

* ALL GRANULAR ROLLED STONE BASE UNDER PROPOSED CONCRETE MUST BE COMPACTED TO 100% OF THE MAXIMUM DENSITY AS DETERMINED BY THE STANDARD PROCTOR TEST AASHTO-99. CONCRETE COMPRESSIVE STRENGTH SHALL BE 4000 PSI IN 28 DAYS.

PROJECT TITLE:
PHOENIX METALS

ENGINEERING SURVEYING
221 Point West Blvd.
St. Charles, MO 63301
636-949-6562
FAX 636-949-1718

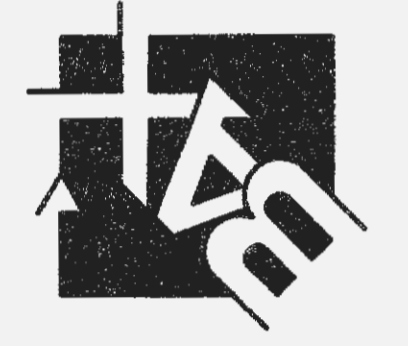

DISCLAIMER OF RESPONSIBILITY
I hereby specify that the documents intended to be submitted by my seal are limited to this project, and I hereby disclaim any responsibility for all other drawings, specifications, estimates, reports or other documents or instruments relating to or intended to be used for any part or subdivision of the architectural or engineering project.

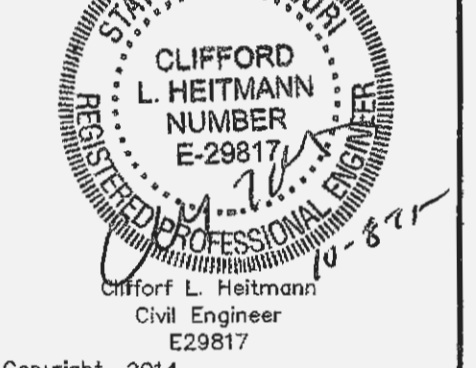

Copyright 2014
Box Engineering Company, Inc.
Engineering Authority No. 000655
Surveying Authority No. 000144
All Rights Reserved

REVISIONS	
01/28/14	CITY COMMENTS
02/03/14	CITY COMMENTS
05/06/14	REVISE UTILITY LAYOUT
08/27/14	REVISE RAIN GARDENS
09/25/14	OWNER REVISIONS
11/20/14	WATER QUAL REVISIONS
12/12/14	CITY COMMENTS
01/28/15	OWNER REVISIONS
02/18/15	CITY/OWNER REVISIONS
04/21/15	CITY/OWNER REVISIONS

Developer / Owner:
MUSM, L.L.C.
2209 DROSTE ROAD
ST. CHARLES, MO 63301
636-949-0680

P+Z No.
#1407.05 & 1407.05.01
Approved May 2, 2013
City No.
#

Page No.
8 of 11