

**FIRE HYDRANT DETAIL
DETAIL "B"
PAGE 1 OF 3**

NOTES

6" PIPES BETWEEN VALVE AND FIRE HYDRANT SHALL BE D.I. "ANCHOR LOKS" OR DUCTILE IRON PIPE WITH "MEGALUG" RESTRAINER FOLLOWER GLANDS ON ALL M.J. JOINTS.

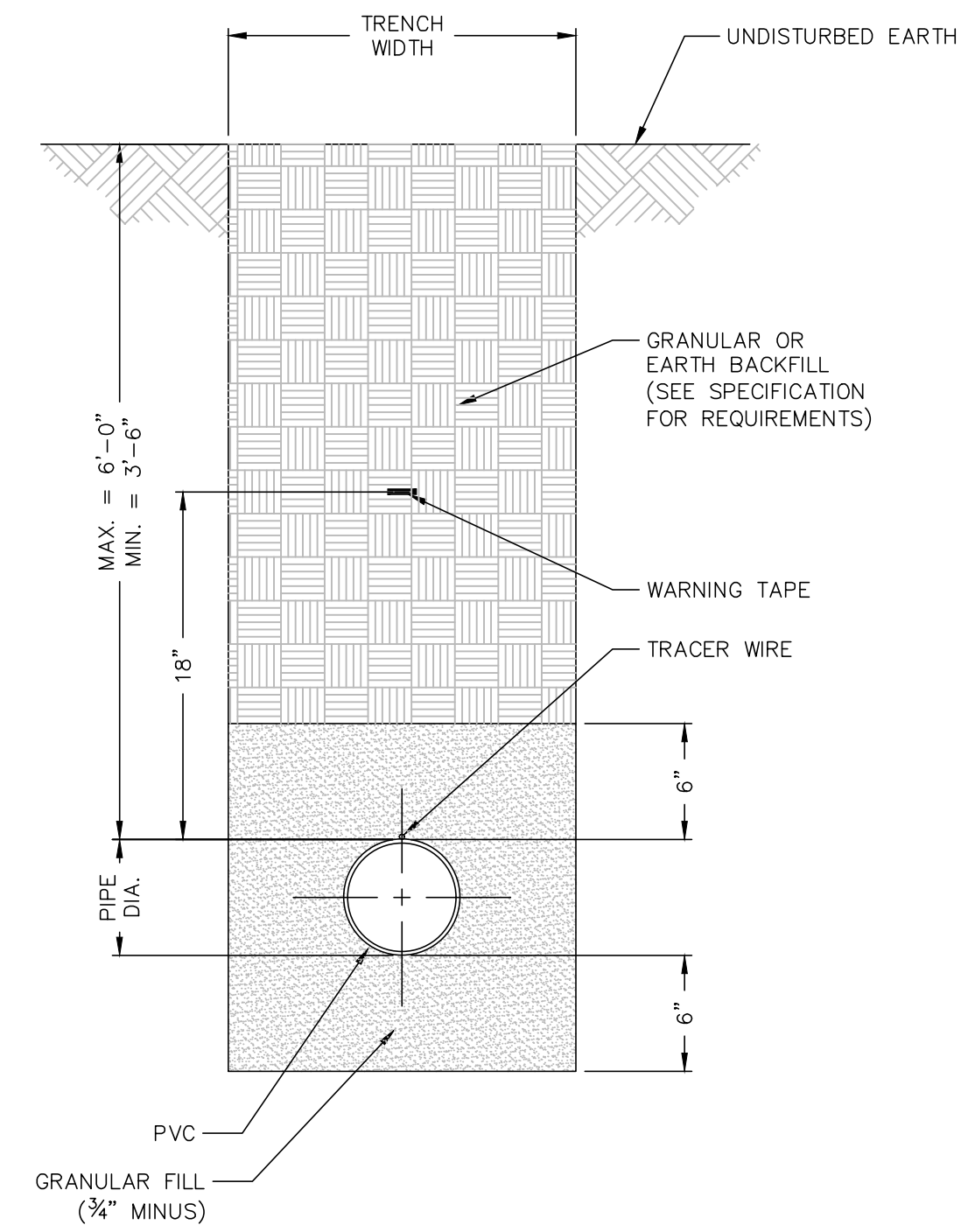

NOTES

1) SEE SPECIFICATIONS FOR ADDITIONAL DETAILS FOR BEDDING AND BACKFILL.

**TYPICAL TRENCH SECTION
FOR PVC PIPE
NOT TO SCALE
DETAIL "A"
PAGE 1 OF 2**

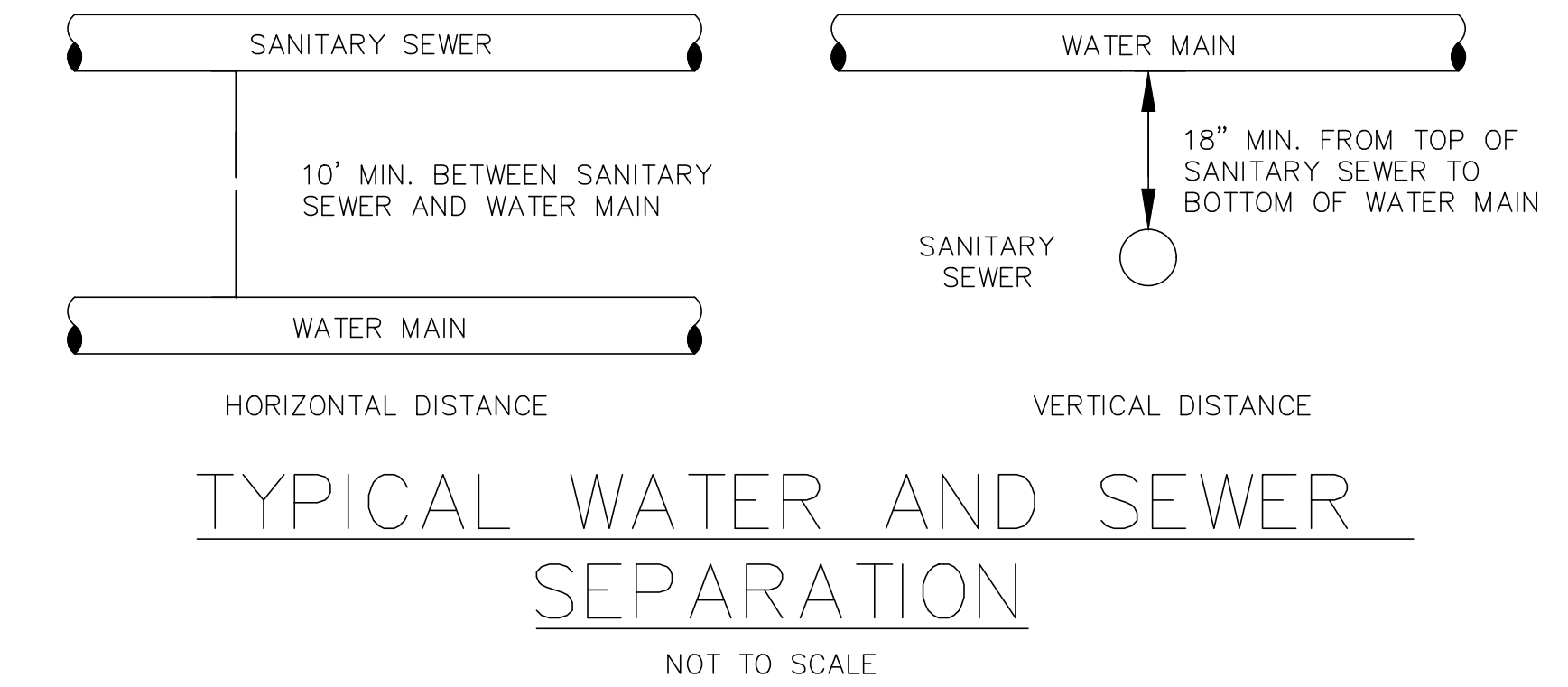

**TYPICAL WATER AND SEWER
SEPARATION
NOT TO SCALE**

CITY OF O'FALLON
ENGINEERING DEPARTMENT
O'FALLON, MISSOURI
**WATER AND SEWER
SEPARATION DETAIL**

RDC Project No. 20-115

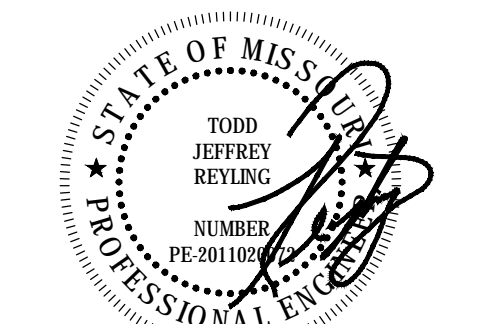

LICENSE EXPIRES - 12.31.2023
DATE SIGNED - 12.01.2021

ENGINEER OF RECORD:
Todd J. Reyling, PE
Missouri PE 2011020072



New Ground Up Building for:
PLANET FITNESS
914 Highway K
O'Fallon, MO 63366
St. Charles County
MTSTUDIO PROJECT NUMBER:

ISSUED / REVISED	DATE
ISSUED TO CITY	05.12.2021
REVISED PER CITY/NOT COMMENTS	07.20.2021
REVISED PER CITY/NOT COMMENTS	08.10.2021
REVISED FOR RETAINING WALL	11.19.2021
REVISED PER CITY COMMENTS	12.01.2021

Civil
Construction
Details

C705

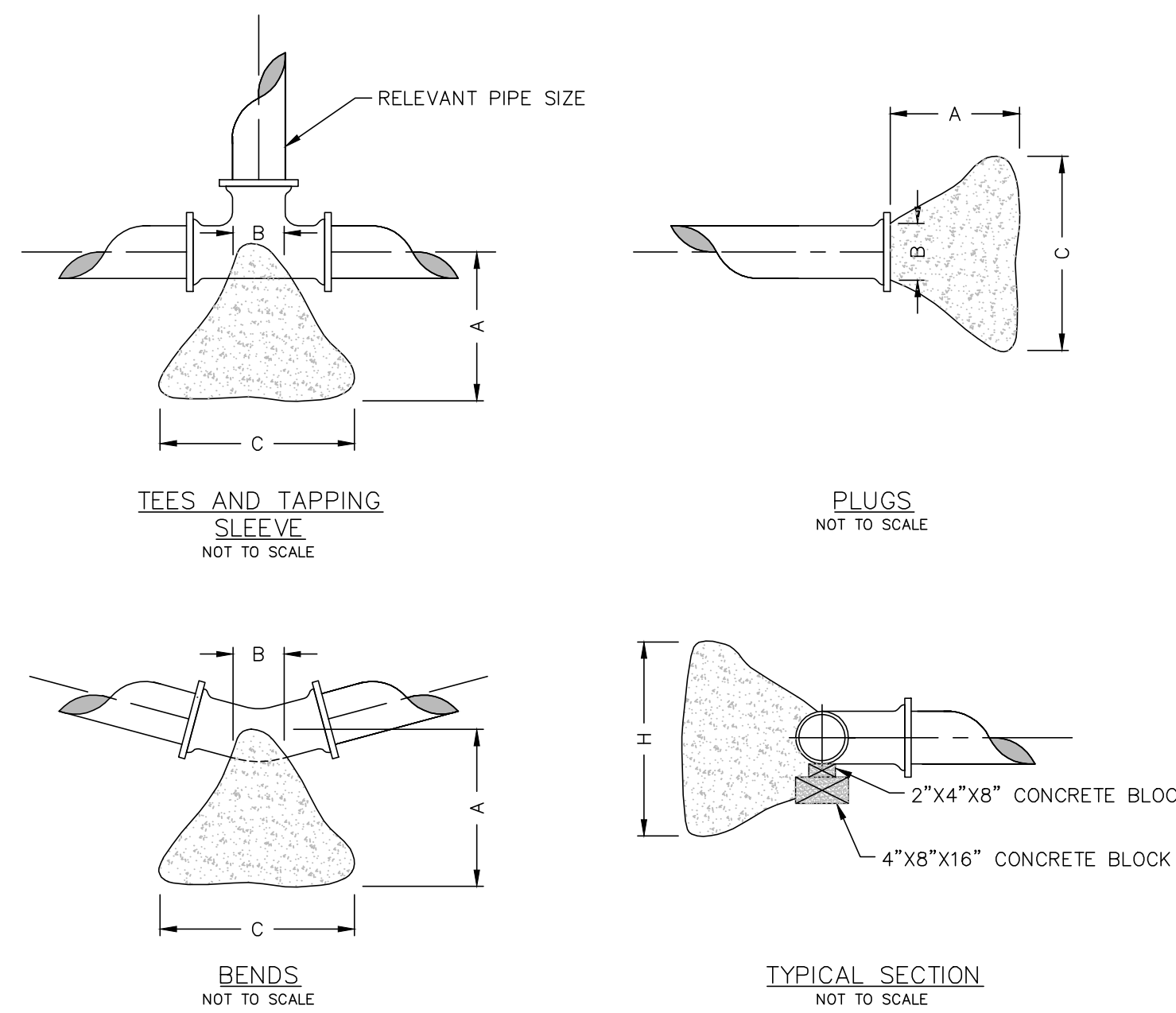

THRUST BLOCK DIMENSIONS - INCHES												
PIPE DIA.	ALL FTGS.		TEE PLUG TAPPING		90 DEGREE BEND		45 DEGREE BEND		22-1/2 BEND		11-1/4 BEND	
	A	B	C	H	C	H	C	H	C	H	C	H
4	14	4	24	12	26	15	18	12	12	12	12	12
6	16	6	36	18	36	24	30	18	24	12	12	12
8	20	8	36	30	42	36	36	24	24	18	18	12
10	20	10	48	36	66	36	36	36	28	24	18	18
12	24	12	68	36	82	42	52	36	40	24	28	18

NOTE

FOR FITTINGS LARGER THAN 12", SPECIAL RESTRAINT DESIGNS ARE REQUIRED.

**HORIZONTAL THRUST BLOCKING
DETAIL "C"**

Buffalo box is an acceptable product to use.
Tyler 562-S and 564-S are acceptable products.

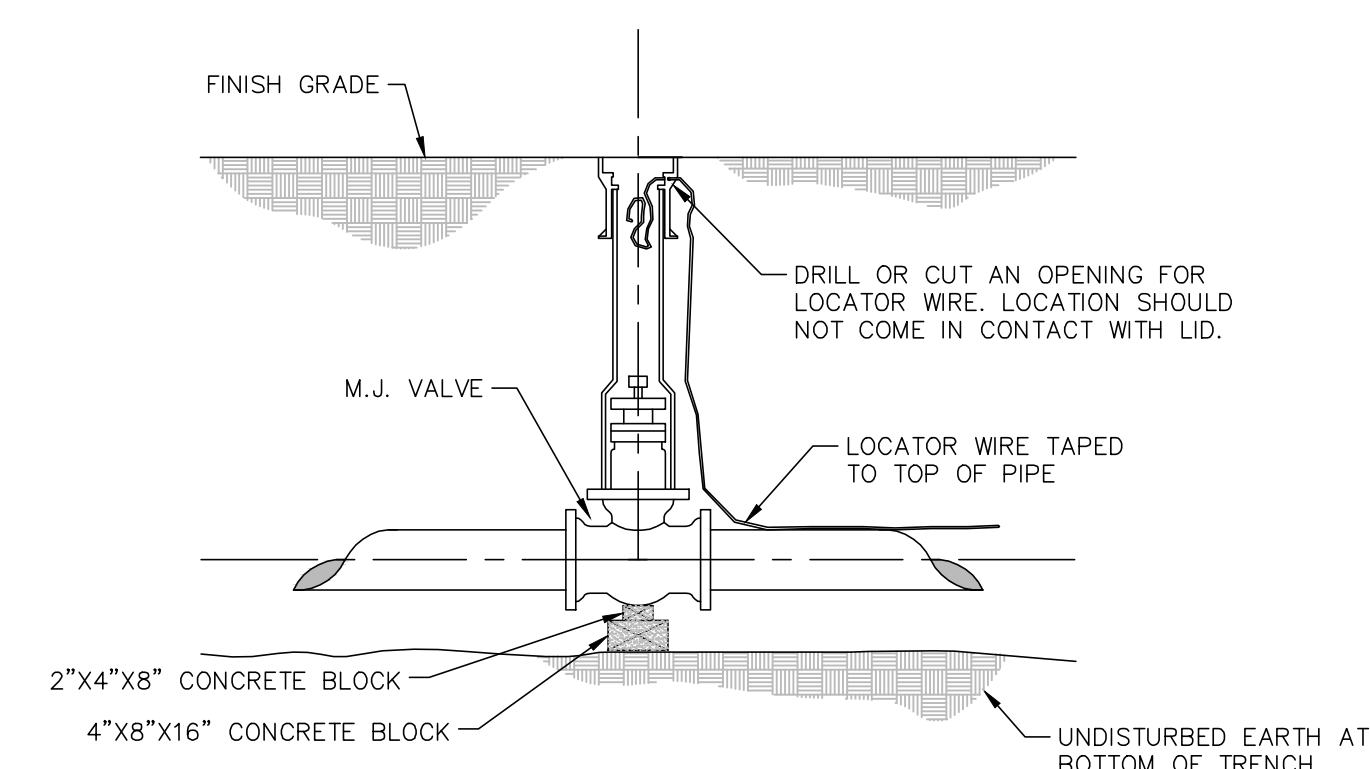

**GATE VALVE DETAIL
NOT TO SCALE
DETAIL "D"**

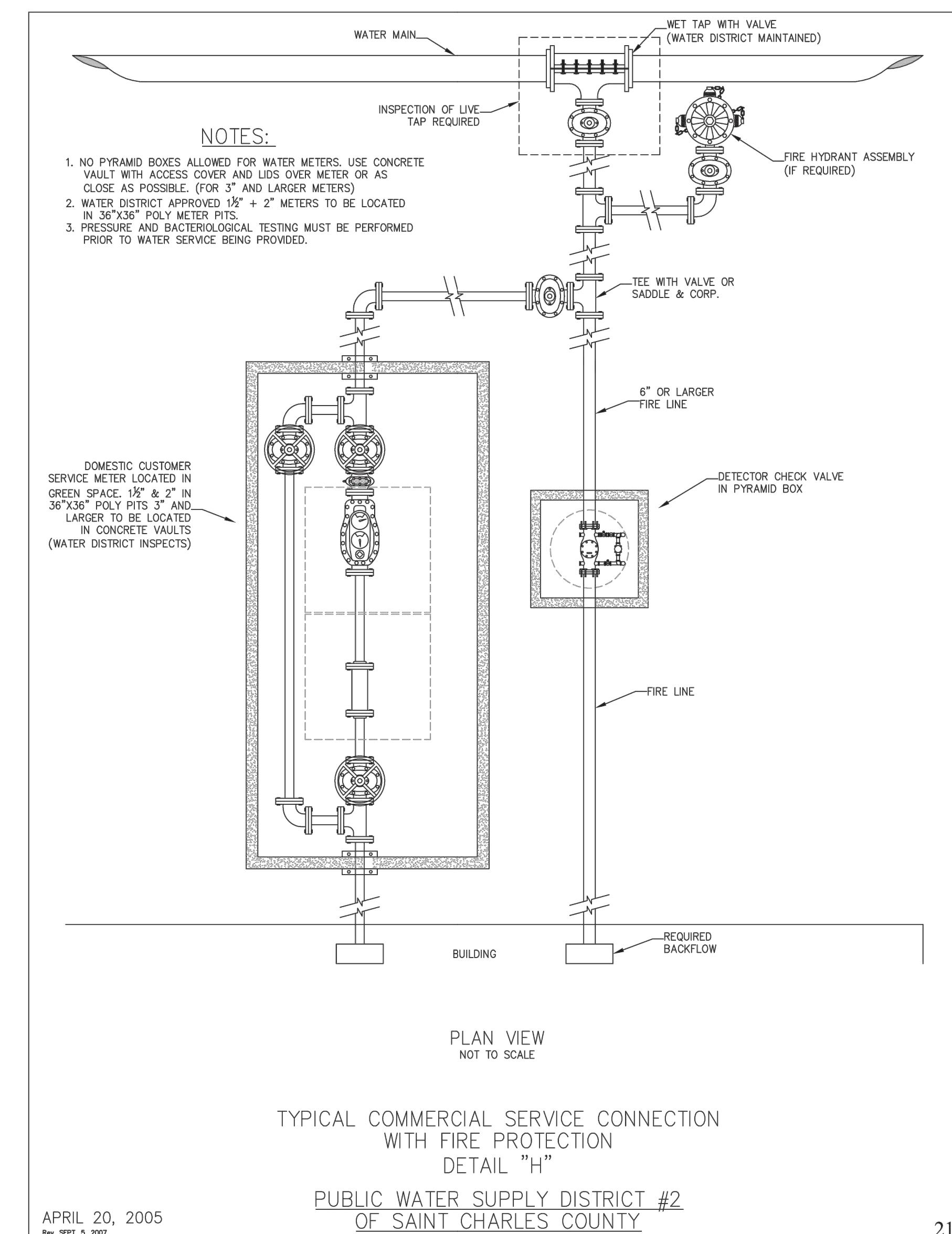

APRIL 20, 2005
REV. 04/20 & 05/01

**TYPICAL COMMERCIAL SERVICE CONNECTION
WITH FIRE PROTECTION
DETAIL "H"
PUBLIC WATER SUPPLY DISTRICT #2
OF SAINT CHARLES COUNTY**