

USER: Mchugh TAB: TEMPLATES 10.0
 DATE: Oct 23, 2007 - 12:06pm
 DRAWING: S:\005\0052007\07-0041\007-0041\img\IMPROVEMENT PLANS PHASE 2\C_PLAN_C10.0_DETAILS.dwg

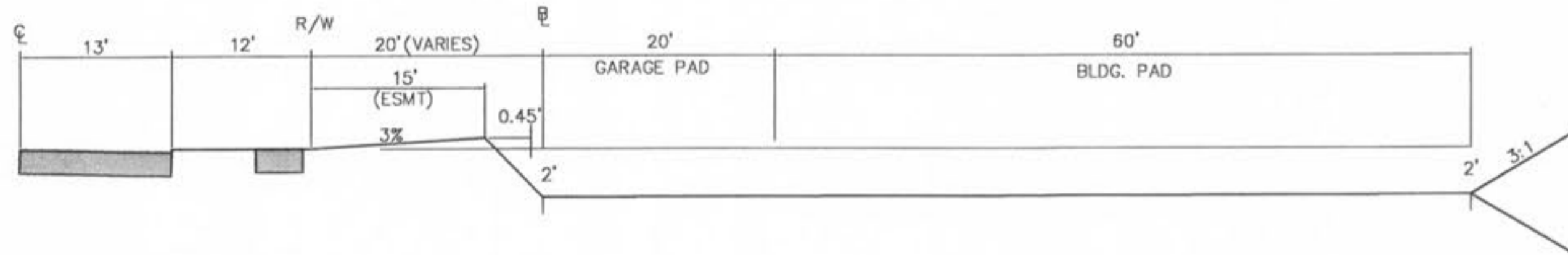

TYPICAL SINGLE FAMILY INGRADE LOT TEMPLATE

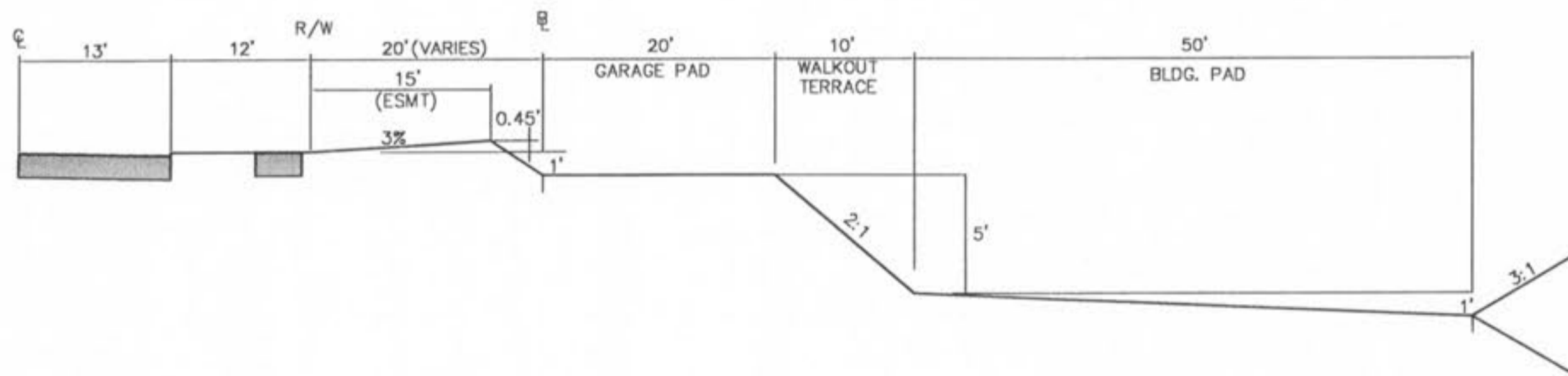

TYPICAL SINGLE FAMILY WALKOUT LOT TEMPLATE

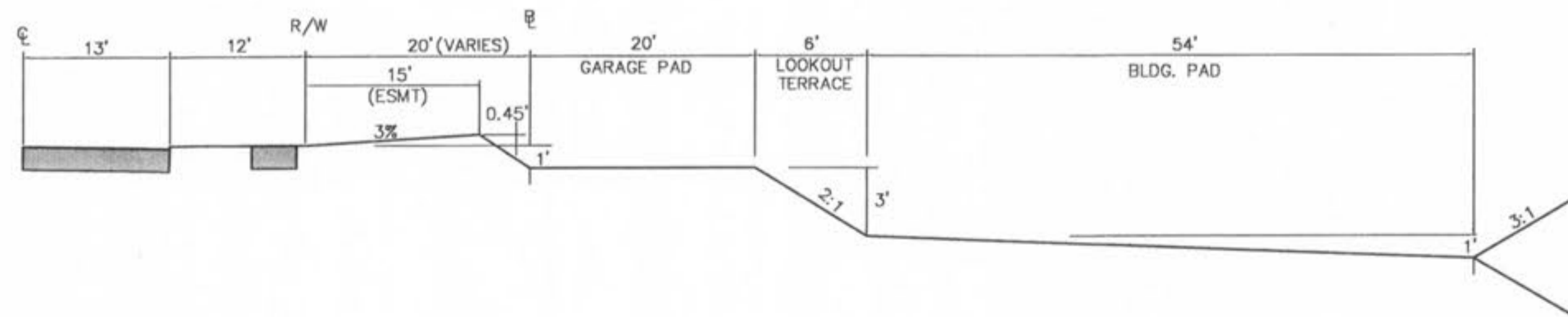

TYPICAL SINGLE FAMILY LOOKOUT LOT TEMPLATE

DESIGN GRADE TEMPLATE

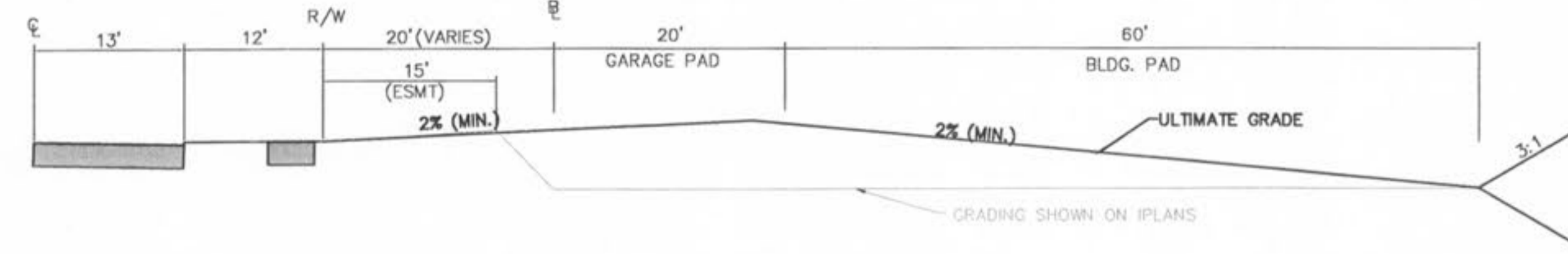

TYPICAL SINGLE FAMILY INGRADE LOT TEMPLATE

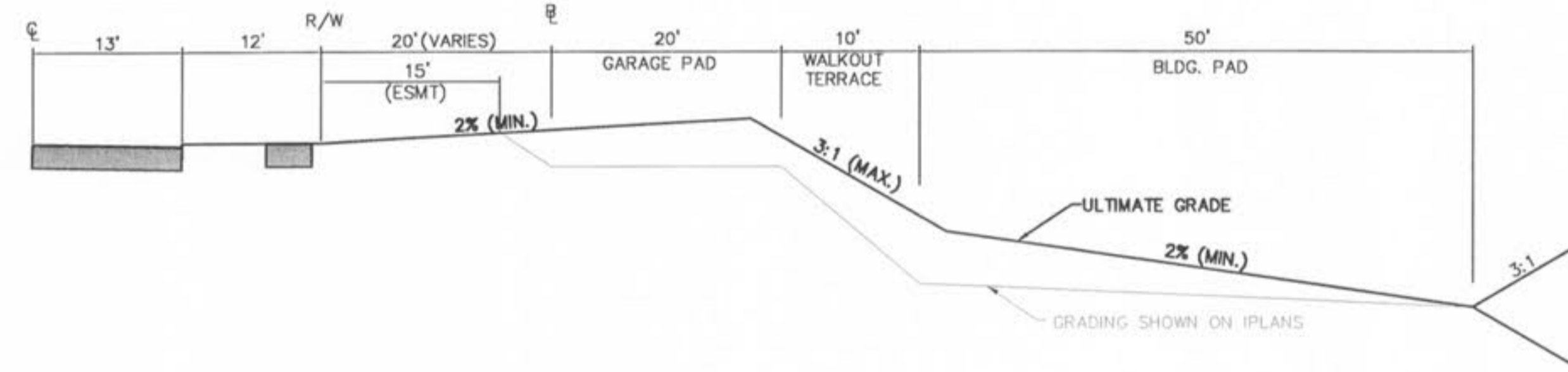

TYPICAL SINGLE FAMILY WALKOUT LOT TEMPLATE

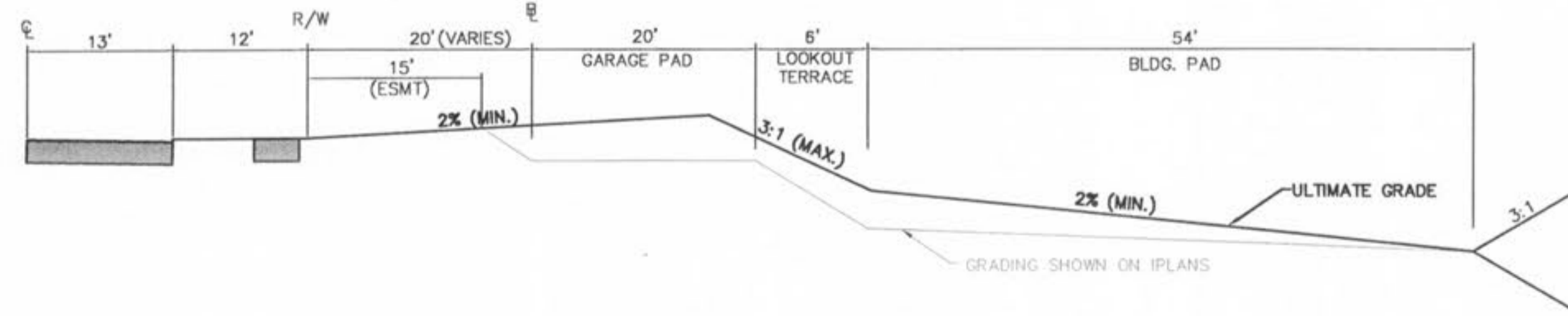

TYPICAL SINGLE FAMILY LOOKOUT LOT TEMPLATE

ULTIMATE GRADE TEMPLATE

DATE	REVISIONS
8/14/07	OWNER/PROVIDER/DUCKETT CREEK
9/14/07	OWNER COMMENTS
9/14/07	DUCKETT CREEK SANITARY DISTRICT
10/12/07	CITY OF FALLON COMMENTS
10/23/07	CITY OF FALLON COMMENTS

DEVELOPER/OWNER:
THE JONES COMPANY HOMES, L.L.C.
 16640 CHESTERFIELD GROVE, SUITE 200
 CHESTERFIELD, MO 63005
 PHONE: (636) 537-7192

THE PROFESSIONAL ENGINEER HAS PERSONAL, REAL WORLD EXPERIENCE
 IN THE DESIGN AND CONSTRUCTION OF RESIDENTIAL DEVELOPMENTS
 AND IS FULLY QUALIFIED TO TAKE RESPONSIBILITY FOR ALL OTHER PLANS
 PREPARED BY HIMSELF OR UNDER HIS SUPERVISION. ANY RESPONSIBILITY
 ASSUMED BY THE UNDERSIGNED PROFESSIONAL RELATING TO OR INTENDED TO BE
 USED FOR ANY PART OR PARTS OF THE PROJECT TO WHICH THIS PAGE REFERS.



PRESTON WOODS - PHASE II
 IMPROVEMENT PLANS
 PRESTON WOODS LANE
 O'FALLON, MO. 63366

RESIDENTIAL GRADING TEMPLATES

planning • engineering • surveying • landscape architecture
Cole
 and ASSOCIATES
 INCORPORATED
 10777 sunset office dr.
 saint louis, missouri 63127
 p: 314 984 9887 f: 314 984 0587

DESIGNED BY: JKW
 DRAWN BY: KDK
 CHECKED BY: JFH
 DATE: 6/14/07
 Job Number: 07-0041
 Sheet Number: C10.0