

ROUND PIPE				HORIZONTAL ELLIPTICAL PIPE			
INSIDE DIAMETER OF PIPE (INCHES)	"W" PAYLINE WIDTH OF TRENCH (INCHES)	"W" PAYLINE WIDTH OF TRENCH (FEET)	PAY-VOLUMES CU. FT. PER FT. CONCRETE ENCASUREMENT	INSIDE DIAMETER OF PIPE (INCHES)	"W" PAYLINE WIDTH OF TRENCH (INCHES)	"W" PAYLINE WIDTH OF TRENCH (FEET)	PAY-VOLUMES CU. FT. PER FT. CONCRETE ENCASUREMENT
4	30	2.50	3.28				
6	30	2.50	3.59				
8	30	2.50	3.87				
10	30	2.50	4.09				
12	30	2.50	4.25				
15	36	3.00	5.55				
18	36	3.00	5.77	14 x 23	41	3.42	5.94
21	39	3.25	6.61				
24	42	3.50	7.39	19 x 30	49	4.08	7.68
27	45	3.75	8.18	22 x 34	53	4.42	8.61
30	49	4.08	9.30	24 x 38	58	4.83	9.70
33	53	4.42	10.53	27 x 42	62	5.17	10.71
36	56	4.67	11.43	29 x 45	66	5.50	11.72
39	DISCONTINUED			32 x 49	71	5.92	13.14
42	63	5.25	13.38	34 x 53	75	6.25	14.05
48	70	5.83	15.67	38 x 60	83	6.92	16.18
54	77	6.42	18.15	43 x 68	92	7.67	18.81
60	84	7.00	20.73	48 x 76	101	8.42	21.59
66	91	7.58	23.45	53 x 83	109	9.08	24.35
72	98	8.17	26.37	58 x 91	118	9.83	27.45
78	105	8.75	29.39	63 x 98	126	10.50	30.50
84	112	9.33	32.57	68 x 106	135	11.25	33.91
90	119	9.92	35.90	72 x 113	143	11.92	36.99
96	126	10.50	39.37	77 x 121	152	12.67	40.69
102	133	11.08	42.99	82 x 128	160	13.33	44.45
108	140	11.67	46.75	87 x 136	168	14.00	47.79
114	147	12.25	50.66	92 x 143	176	14.67	51.70
120	154	12.83	54.72	97 x 151	185	15.42	56.01
126	161	13.42	58.92				
132	168	14.00	63.27	106 x 166	202	16.83	64.48
144	182	15.17	72.40	116 x 180	218	18.17	73.59

**Duckett Creek Sanitary District**

PAYLINE WIDTHS OF TRENCH AND PAY-QUANTITIES OF CONCRETE

Drawn By: BSM	App. By: KLA	Detail No. 1
Check By: MDOB	Date: 12-21-99	

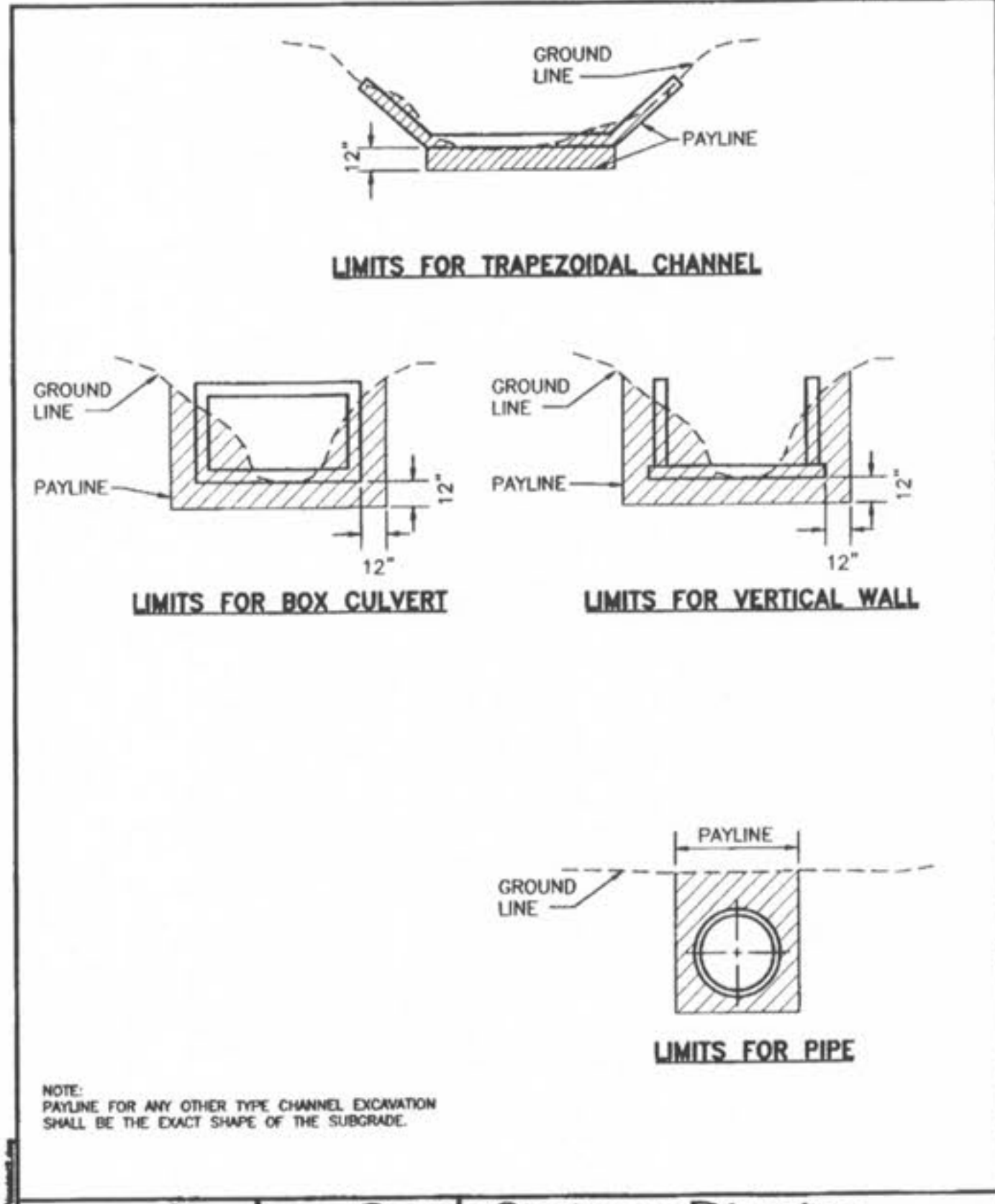

**Duckett Creek Sanitary District**

PAYLINE LIMITS FOR EXCAVATION

Drawn By: BSM	App. By: KLA	Detail No. 2
Check By: MDOB	Date: 12-21-99	

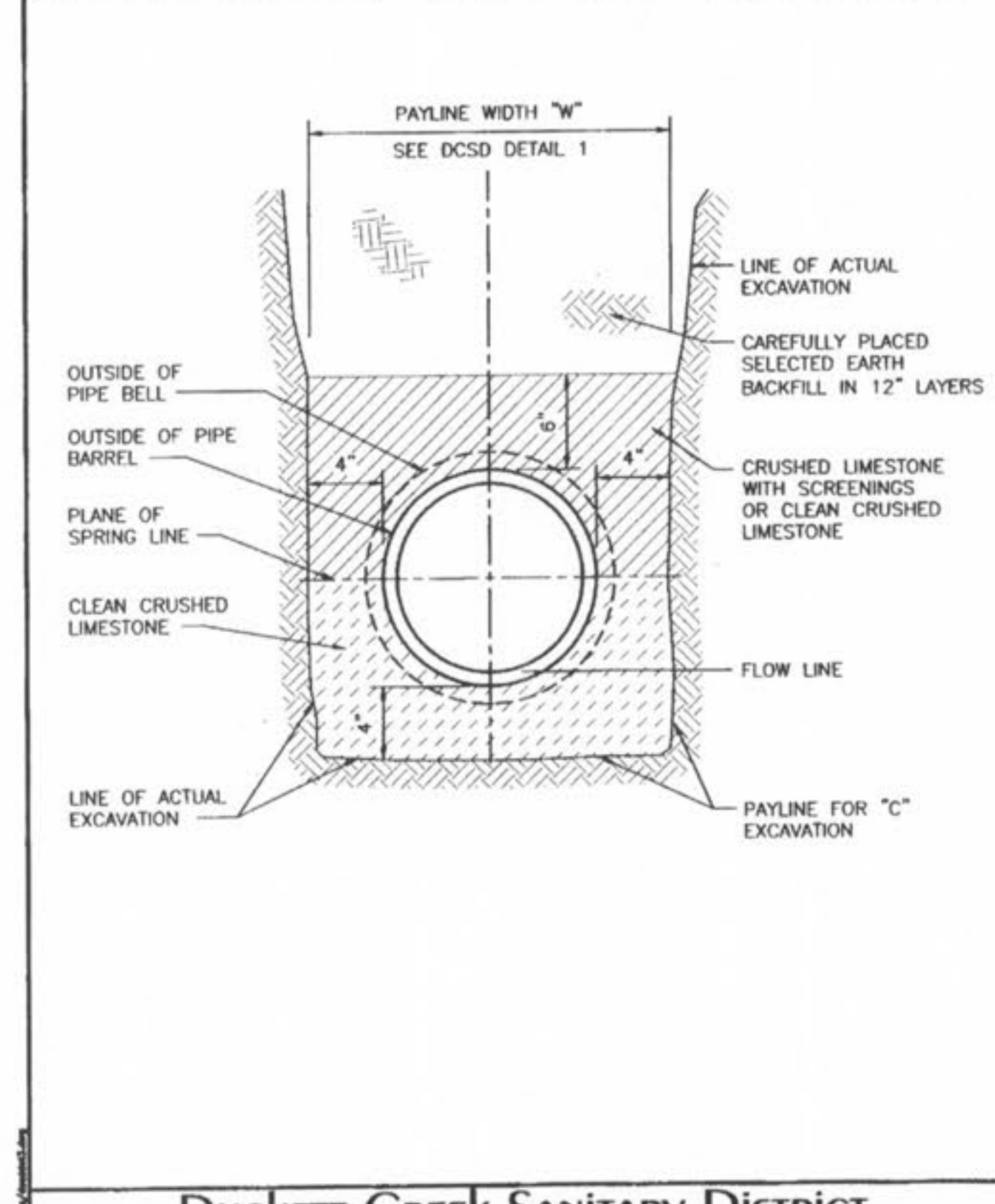

Drawn By: BSM	App. By: KLA	Detail No. 3
Check By: MDOB	Date: 12-21-99	

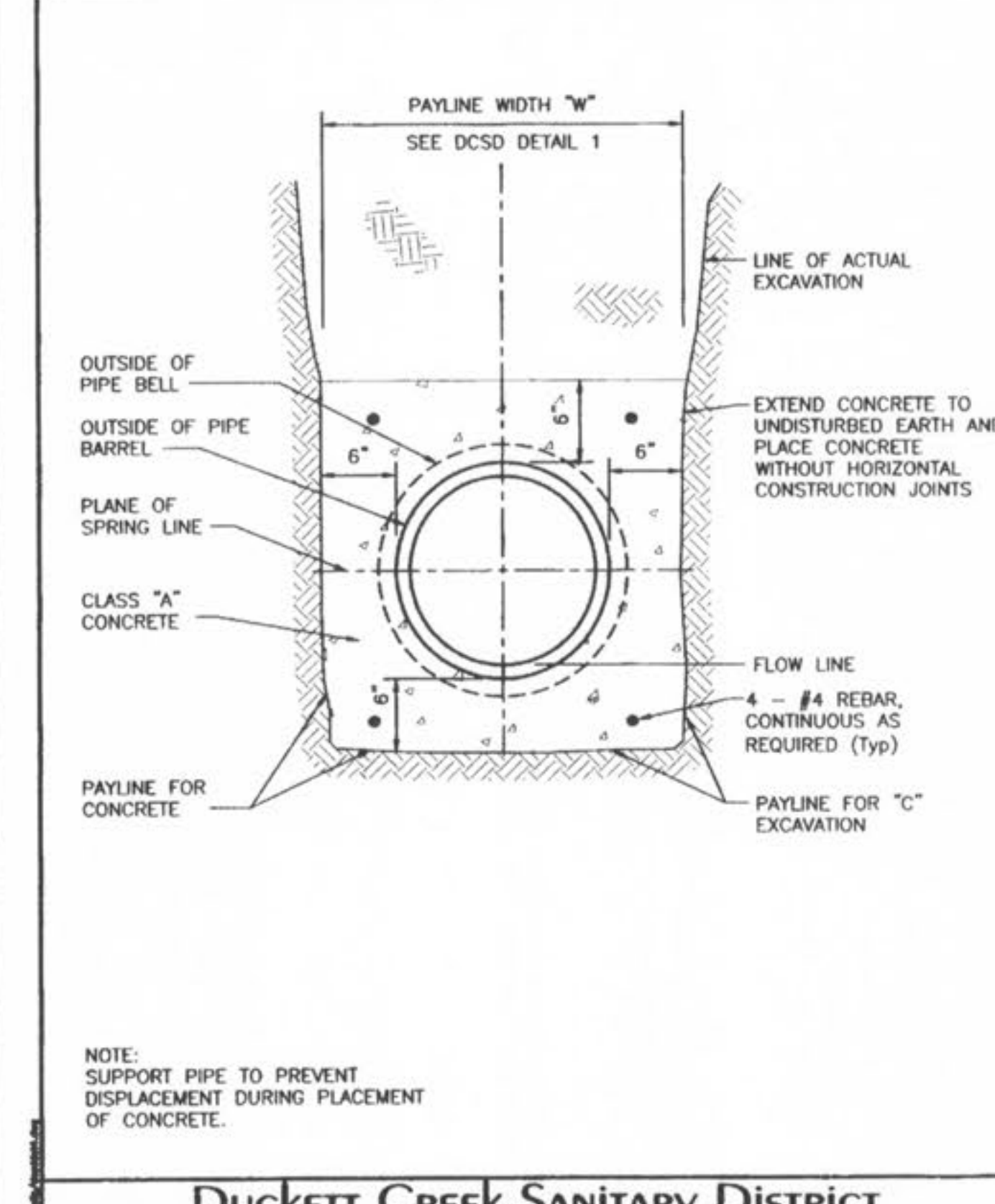

Drawn By: BSM	App. By: KLA	Detail No. 4
Check By: MDOB	Date: 12-21-99	

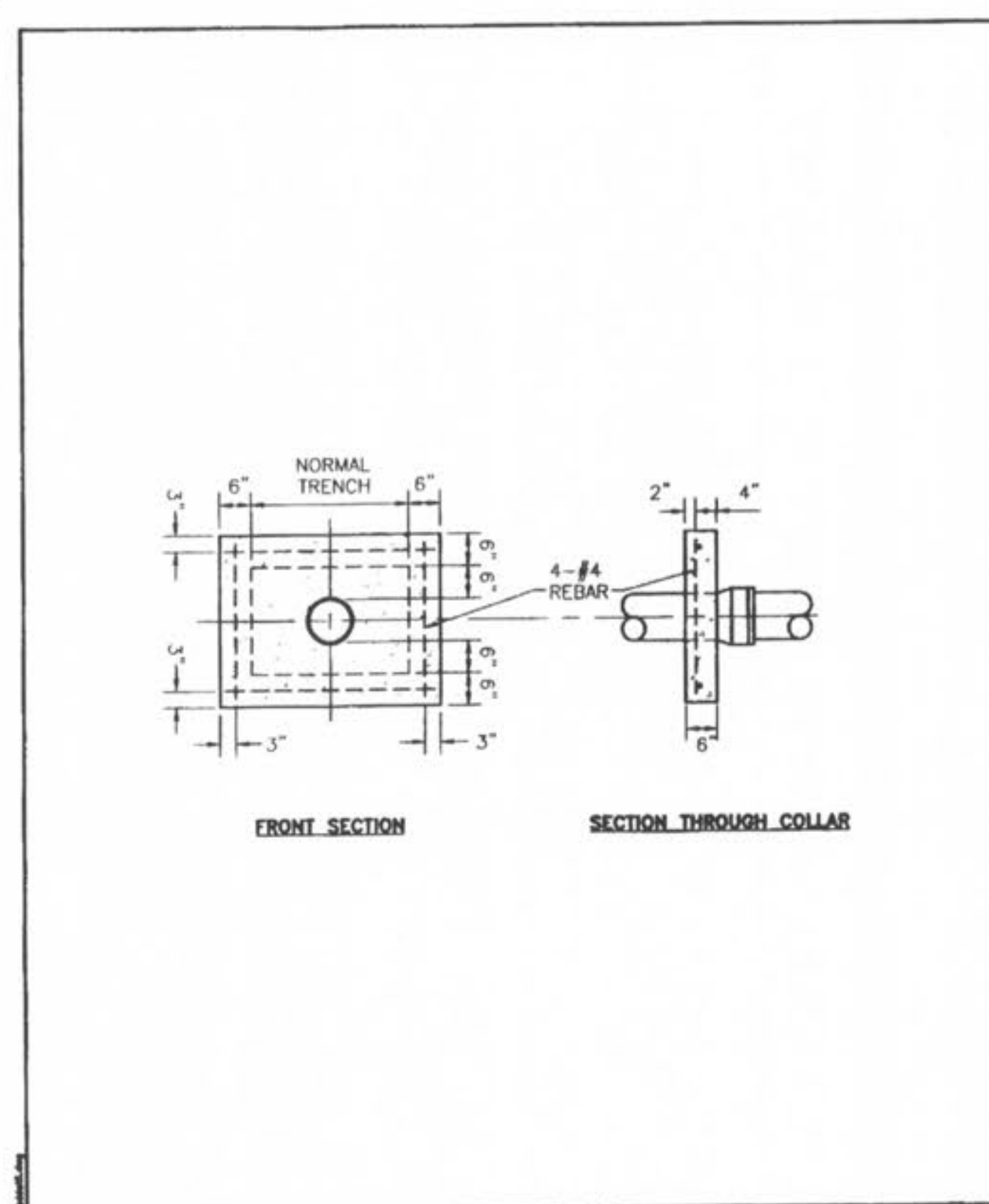

Drawn By: BSM	App. By: KLA	Detail No. 5
Check By: MDOB	Date: 12-21-99	

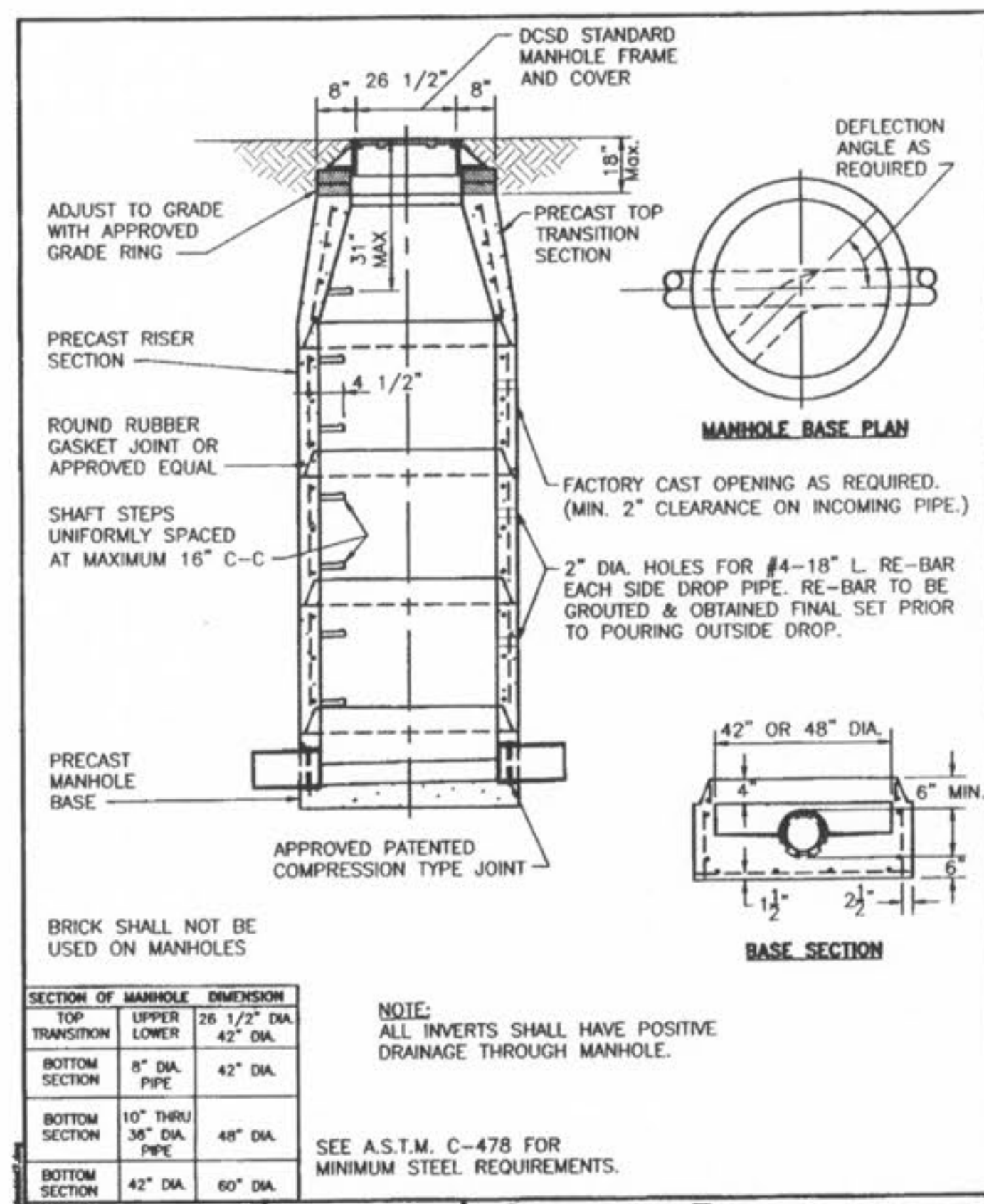

Drawn By: BSM	App. By: KLA	Detail No. 7
Check By: MDOB	Date: 12-30-99	

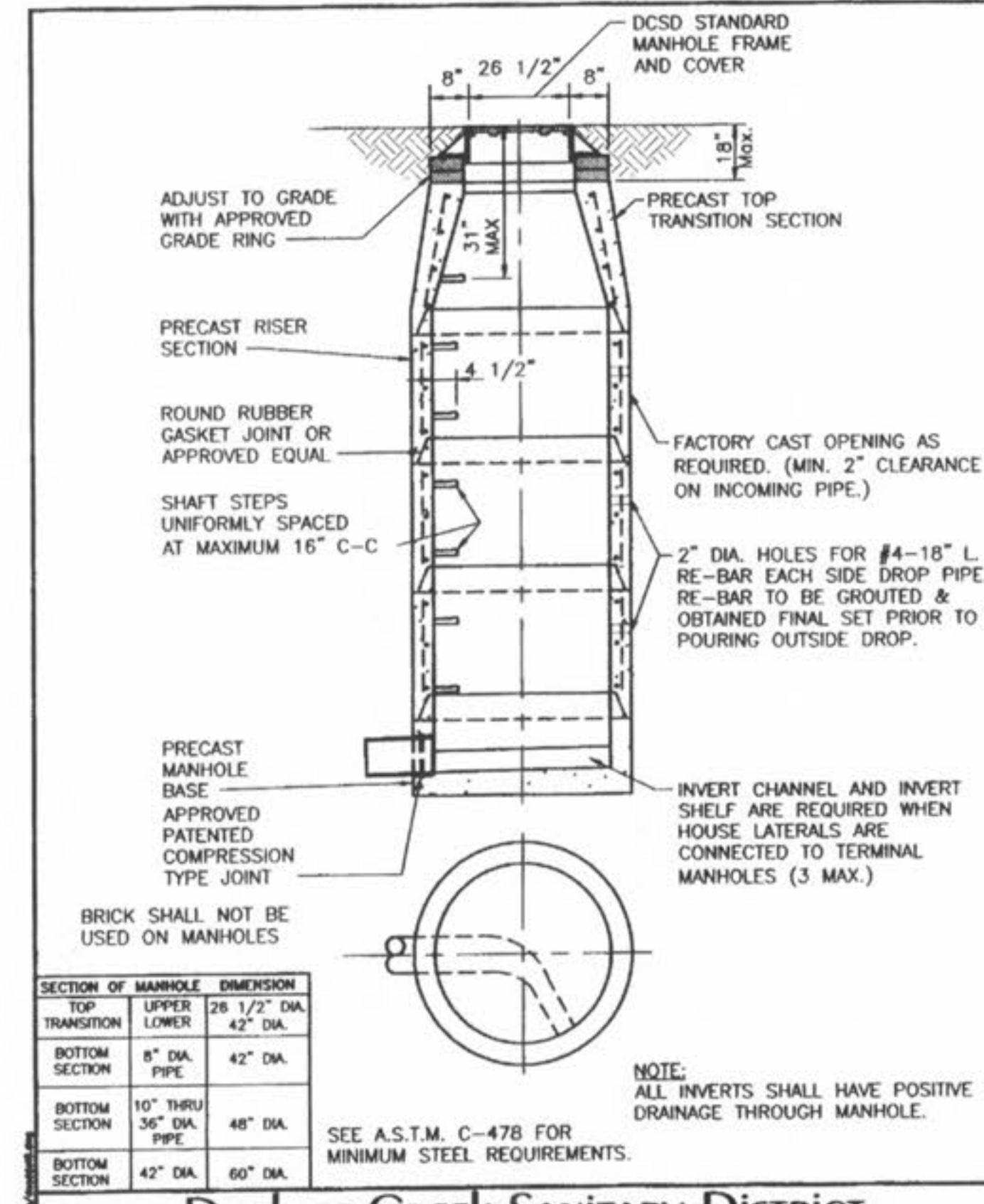

Drawn By: BSM	App. By: KLA	Detail No. 8
Check By: MDOB	Date: 01-03-00	

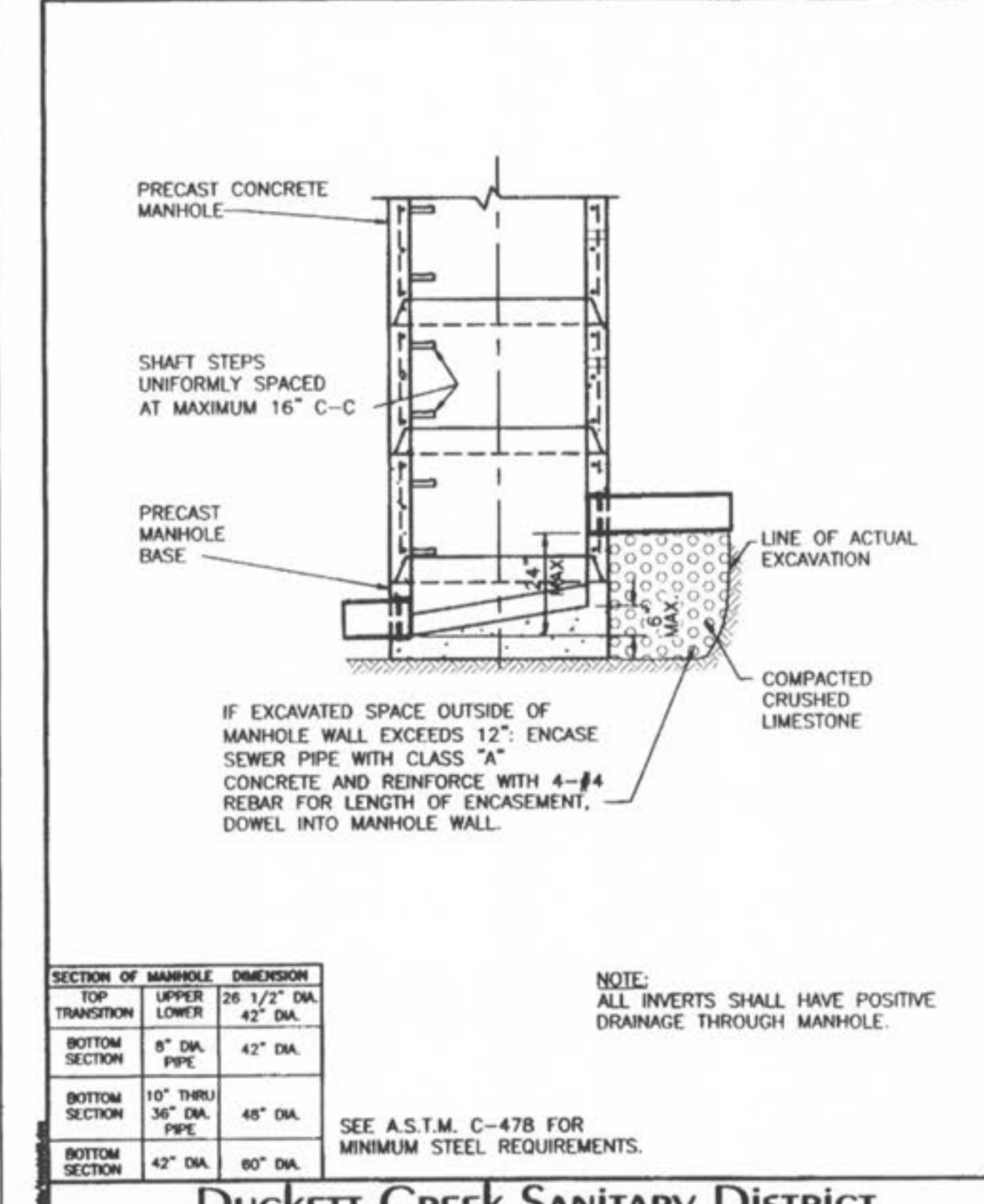

Drawn By: BSM	App. By: KLA	Detail No. 9
Check By: MDOB	Date: 01-04-00	

USER: A:\proj\15\ SANITARY\151\ 12-20-99\151.DWG  
 DRAWING: S:\A\BBS\150207\07-0041\07-0041.dwg IMPROVEMENT PLANS PHASE 2\0\_Plan\_C10.0.DETAILS.dwg

**PRESTON WOODS - PHASE II**  
IMPROVEMENT PLANS  
SANITARY SEWER DETAILSPRESTON WOODS, LANE  
O'FALLON, MO. 63366

**Cole and Associates INCORPORATED**  
10777 sunset office dr  
saint louis, missouri 63127  
p: 314 984 9887 f: 314 984 0887

DESIGNED BY: JKW  
DRAWN BY: KDK  
CHECKED BY: JFH  
DATE: 6/14/07  
Job Number: 07-0041  
Sheet Number: C10.1

REVISIONS

DATE	BY	DESCRIPTION
8/24/07	OWNER/PWSH/JZ/DUCKETT CREEK	
9/14/07	PWSH/JZ	
9/14/07	OWNER COMMENTS	
10/12/07	CITY OF FALLOON COMMENTS	
10/12/07	CITY OF FALLOON COMMENTS	
10/12/07	CITY OF FALLOON COMMENTS	
10/23/07	CITY OF FALLOON COMMENTS	

THE PROFESSIONAL ENGINEER'S SIGNATURE AND PERSONAL SEAL SHALL BE PLACED HEREIN. THE PROFESSIONAL ENGINEER'S SIGNATURE AND PERSONAL SEAL SHALL BE PLACED HEREIN. THE PROFESSIONAL ENGINEER'S SIGNATURE AND PERSONAL SEAL SHALL BE PLACED HEREIN. THE PROFESSIONAL ENGINEER'S SIGNATURE AND PERSONAL SEAL SHALL BE PLACED HEREIN. THE PROFESSIONAL ENGINEER'S SIGNATURE AND PERSONAL SEAL SHALL BE PLACED HEREIN.

NOTE: THE DETAILS SHOWN HEREIN ARE FOR THE PURPOSE OF PRIVATE CONSTRUCTION ONLY. PUBLIC CONSTRUCTION WILL REQUIRE STRICT ADHERENCE TO THE DETAILS PUBLISHED BY DUCKETT CREEK AND ST. CHARLES COUNTY.