

ROUND PIPE				HORIZONTAL ELLIPTICAL PIPE			
INSIDE DIAMETER OF PIPE (INCHES)	"W" PAYLINE WIDTH OF TRENCH (INCHES)	"W" PAYLINE WIDTH OF TRENCH (FEET)	PAY-VOLUMES CU. FT. PER FT. CONCRETE ENCASEMENT	INSIDE DIAMETER OF PIPE (INCHES)	"W" PAYLINE WIDTH OF TRENCH (INCHES)	"W" PAYLINE WIDTH OF TRENCH (FEET)	PAY-VOLUMES CU. FT. PER FT. CONCRETE ENCASEMENT
4	30	2.50	3.28				
6	30	2.50	3.59				
8	30	2.50	3.87				
10	30	2.50	4.09				
12	30	2.50	4.25				
15	36	3.00	5.55				
18	36	3.00	5.77	14 x 23	41	3.42	5.94
21	39	3.25	6.61				
24	42	3.50	7.39	19 x 30	49	4.08	7.68
27	45	3.75	8.18	22 x 34	53	4.42	8.61
30	49	4.08	9.30	24 x 38	58	4.83	9.70
33	53	4.42	10.53	27 x 42	62	5.17	10.71
36	56	4.67	11.43	29 x 45	66	5.50	11.72
39		DISCONTINUED		32 x 49	71	5.92	13.14
42	63	5.25	13.38	34 x 53	75	6.25	14.05
48	70	5.83	15.67	38 x 60	83	6.92	16.18
54	77	6.42	18.15	43 x 68	92	7.67	18.81
60	84	7.00	20.73	48 x 76	101	8.42	21.59
66	91	7.58	23.45	53 x 83	109	9.08	24.35
72	98	8.17	26.37	58 x 91	118	9.83	27.45
78	105	8.75	29.39	63 x 98	126	10.50	30.50
84	112	9.33	32.57	68 x 106	135	11.25	33.91
90	119	9.92	35.90	72 x 113	143	11.92	36.99
96	126	10.50	39.37	77 x 121	152	12.67	40.69
102	133	11.08	42.99	82 x 128	160	13.33	44.45
108	140	11.67	46.75	87 x 136	168	14.00	47.79
114	147	12.25	50.66	92 x 143	176	14.67	51.70
120	154	12.83	54.72	97 x 151	185	15.42	56.01
126	161	13.42	58.92				
132	168	14.00	63.27	106 x 166	202	16.83	64.48
144	182	15.17	72.40	116 x 180	218	18.17	73.59

DUCKETT CREEK SANITARY DISTRICT

PAYLINE WIDTHS OF TRENCH AND PAY-QUANTITIES OF CONCRETE

Dim By: BSM	App By: KLA	Detail No. 1
Chd By: MDOB	Date: 12-21-99	

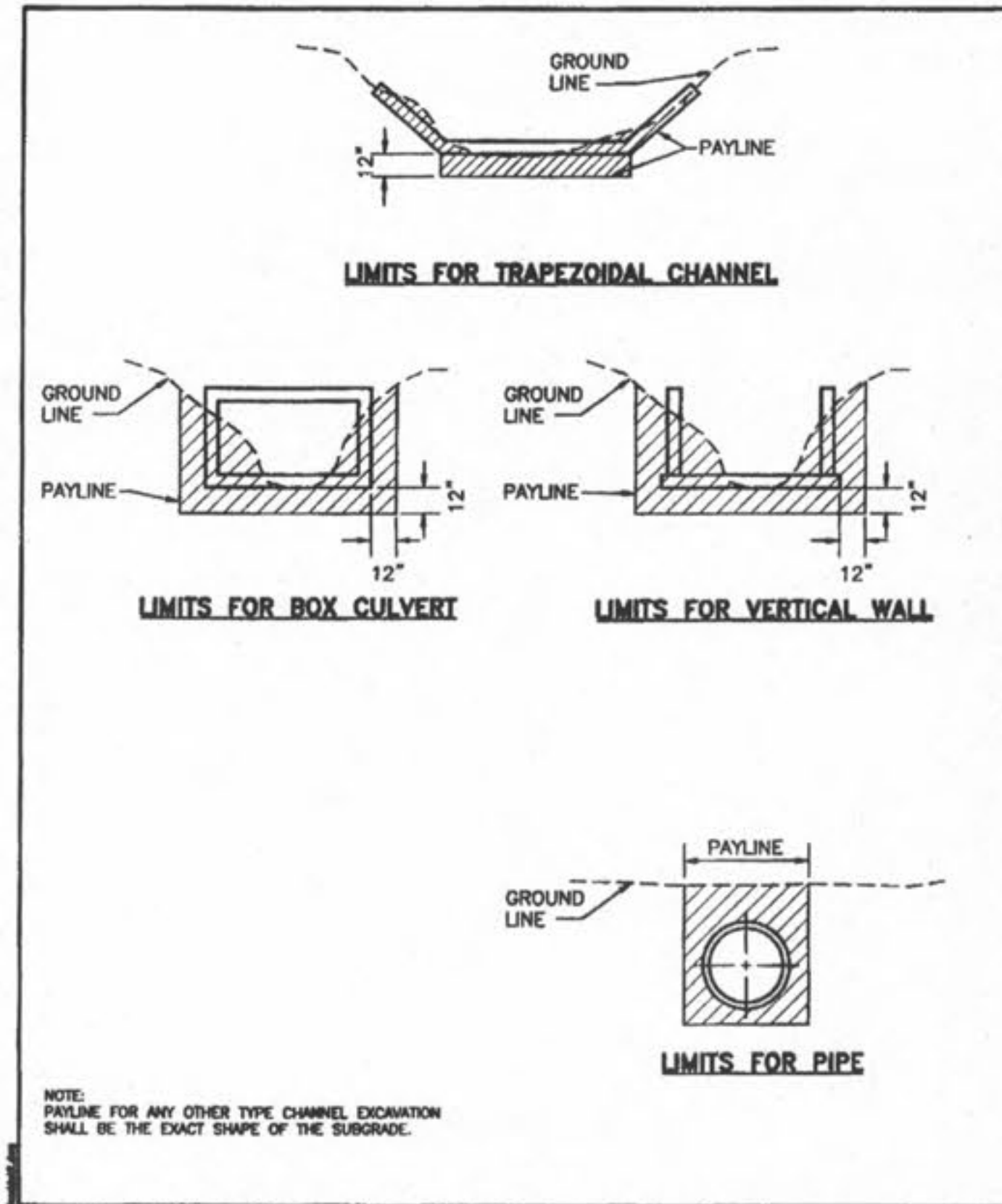

DUCKETT CREEK SANITARY DISTRICT

PAYLINE LIMITS FOR EXCAVATION

Dim By: BSM	App By: KLA	Detail No. 2
Chd By: MDOB	Date: 12-21-99	

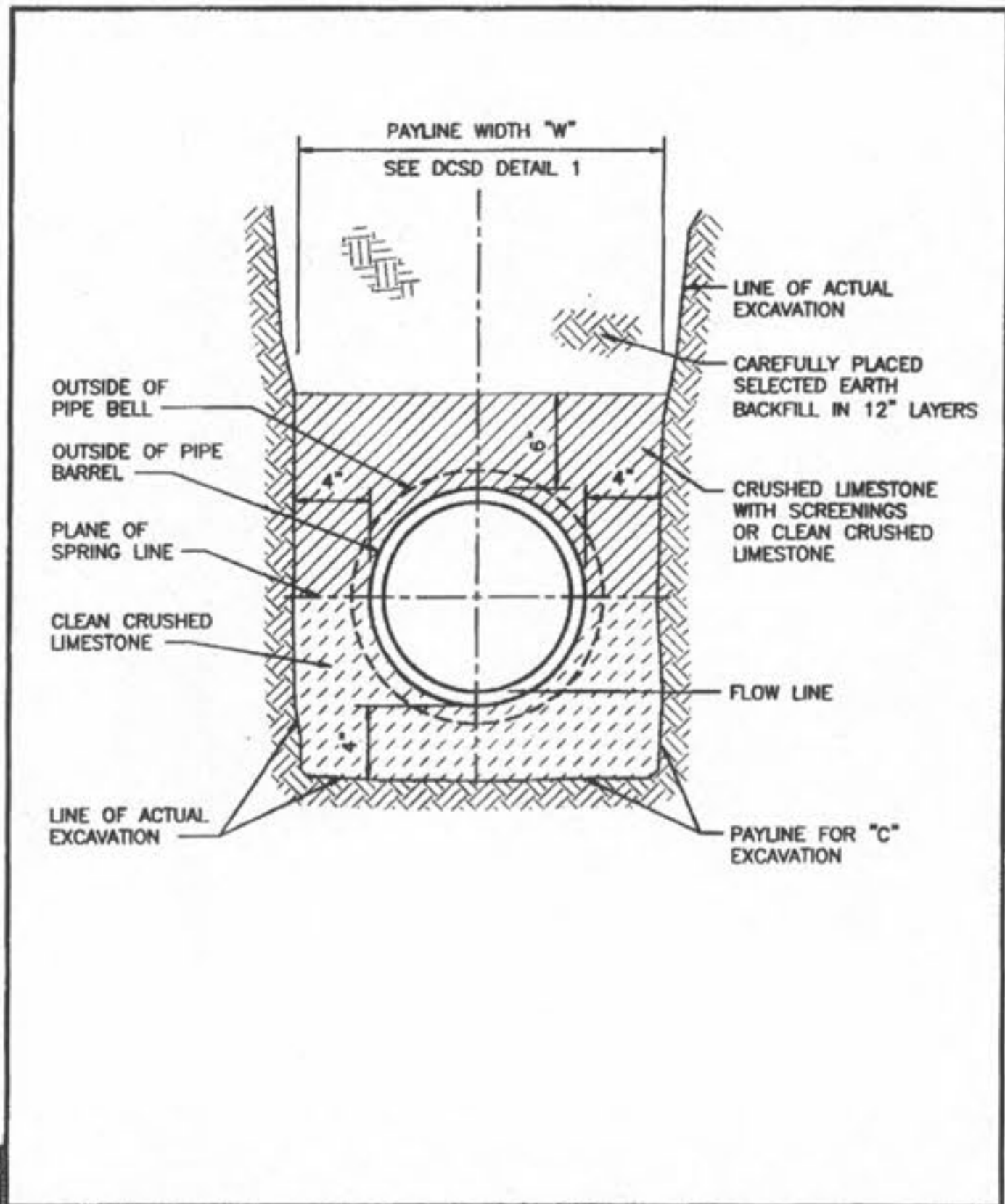

Dim By: BSM	App By: KLA	Detail No. 3
Chd By: MDOB	Date: 12-21-99	

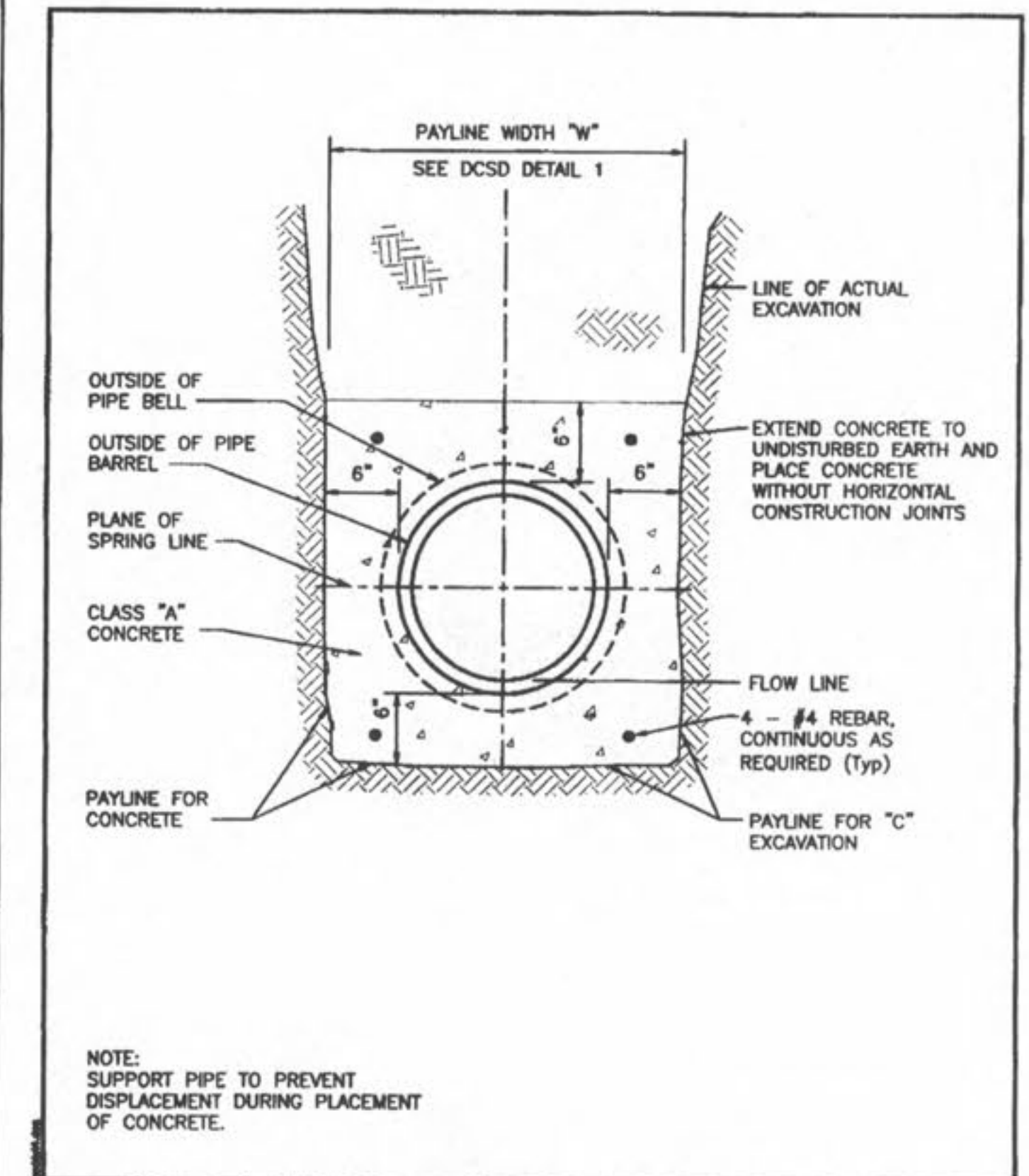

Dim By: BSM	App By: KLA	Detail No. 4
Chd By: MDOB	Date: 12-21-99	

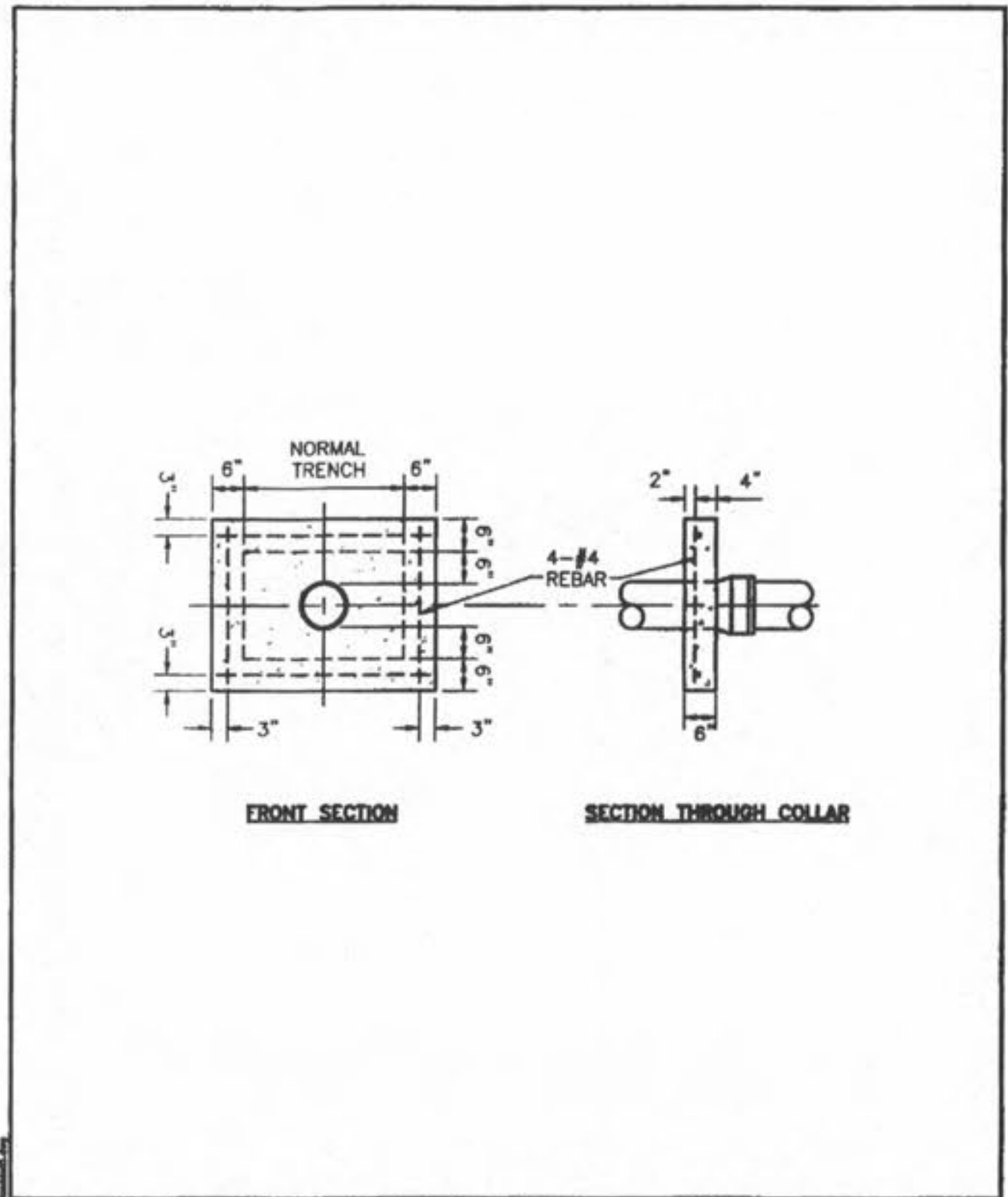

Dim By: BSM	App By: KLA	Detail No. 5
Chd By: MDOB	Date: 12-21-99	

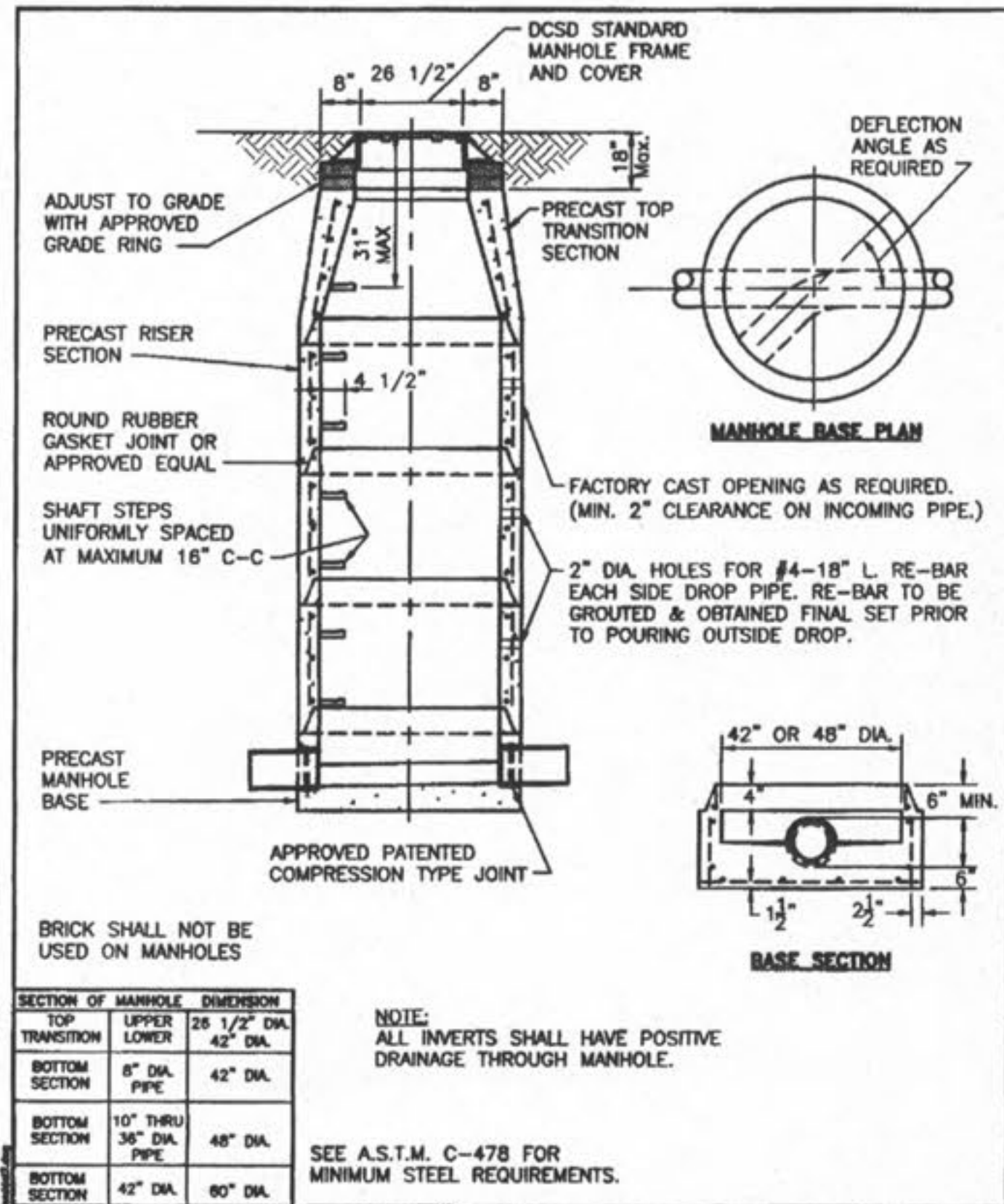

Dim By: BSM	App By: KLA	Detail No. 7
Chd By: MDOB	Date: 12-30-99	

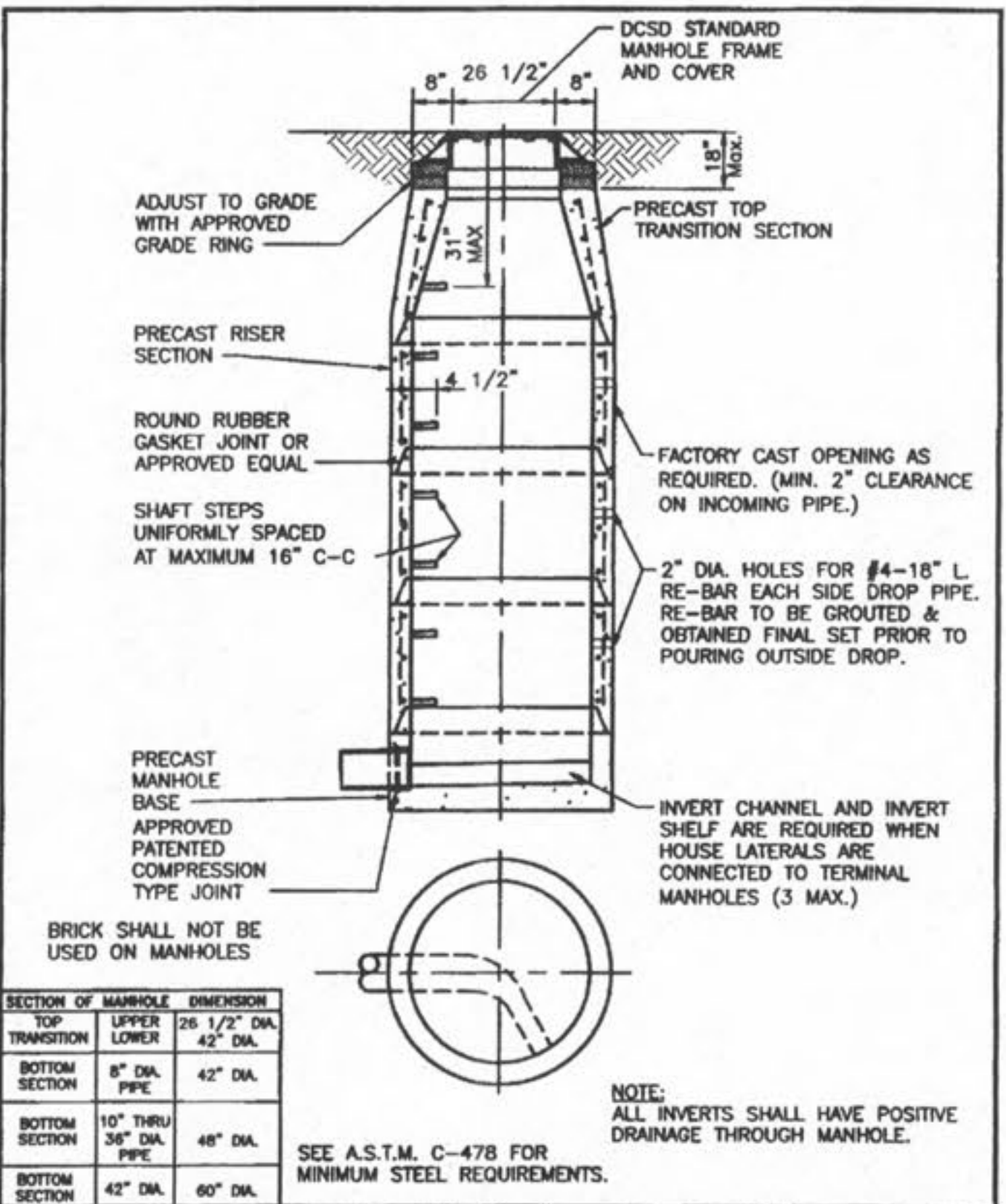

Dim By: BSM	App By: KLA	Detail No. 8
Chd By: MDOB	Date: 01-03-00	

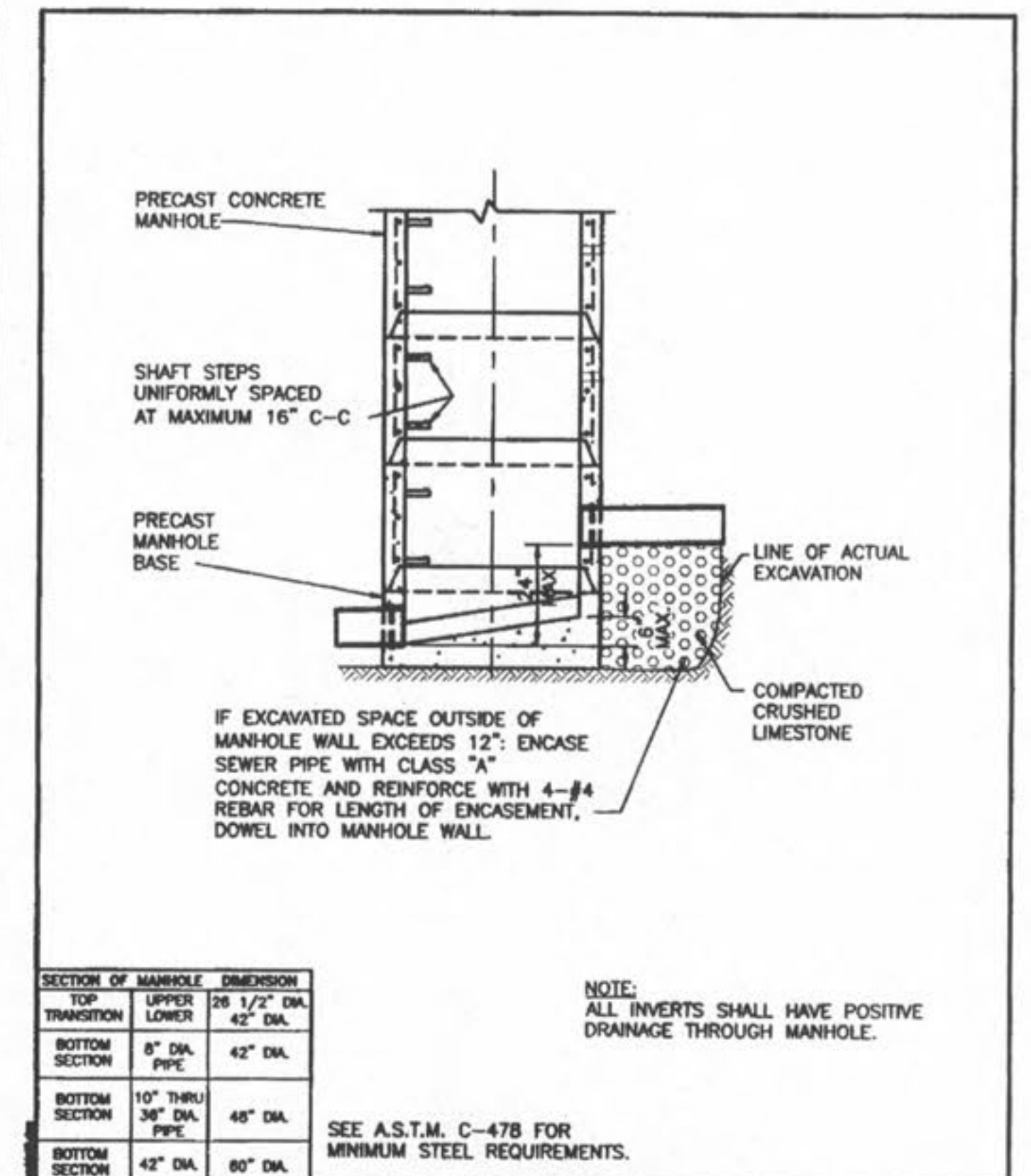

Dim By: BSM	App By: KLA	Detail No. 9
Chd By: MDOB	Date: 01-04-00	

USER: J:\plan\TAB: SANITARY 8.1
 DATE: Jul 10, 2008 - 9:32am
 DRAWING: S:\LORDS\lmsz008\08-0033\view\IMPROVEMENT PLANS PHASE 4\0_Plan_C9.0_DETAILS.dwg

REVISIONS

NO.	DATE	BY	REASON
1	8/10/08	BSM	OWNER COMMENTS
2	7/10/08	KLA	CITY COMMENTS

DEVELOPER/OWNER: THE JONES COMPANY HOMES, L.L.C.
 16640 CHESTERFIELD GROVE, SUITE 200
 CHESTERFIELD, MO 63005
 PHONE: (636) 537-7192

THE PROFESSIONAL ENGINEER'S SEAL AND SIGNATURE ARE NECESSARY FOR ANY DESIGN OR SPECIFICATION. THE ENGINEER ASSUMES RESPONSIBILITY ONLY FOR WHAT APPEARS ON THIS PLAN AND DOES NOT ASSUME RESPONSIBILITY FOR ALL OTHER PLANS. THIS PLAN IS TO BE SEaled BY THE UNDERSIGNED PROFESSIONAL ENGINEER. NO PART OF THIS PLAN IS TO BE REPRODUCED OR TRANSMITTED IN ANY FORM OR BY ANY MEANS, ELECTRONIC OR MECHANICAL, INCLUDING PHOTOCOPYING, RECORDING, OR BY ANY INFORMATION STORAGE AND RETRIEVAL SYSTEM, WITHOUT THE WRITTEN PERMISSION OF THE ENGINEER.

SEAL: [Professional Engineer Seal]

PRESTON WOODS - PHASE 4
 IMPROVEMENT PLANS
 PRESTON WOODS LANE
 O'FALLON, MO. 63366

SANITARY SEWER DETAILS

planning • engineering • surveying • landscape architecture
Cole and Associates Incorporated
 10777 sunset office dr.
 saint louis, missouri 63127
 p. 314.984.9887 f. 314.984.0587

DESIGNED BY: JKW
 DRAWN BY: JKW
 CHECKED BY: JFH
 DATE: 4/9/08
 Job Number: 08-0033
 Sheet Number: C9.1

NOTE: THE DETAILS SHOWN HEREIN ARE FOR THE PURPOSE OF PRIVATE CONSTRUCTION ONLY. PUBLIC CONSTRUCTION WILL REQUIRE STRICT ADHERENCE TO THE DETAILS PUBLISHED BY DUCKETT CREEK AND ST. CHARLES COUNTY.