

SIZE	CATALOG NO.	A	B	C	D	E	F	G	H	CT	PT
4"	334-040	4.56	8.23	4.25	4.10	3.94	4.80	2.72	2.7	.32	.25
6"	334-060	6.68	9.93	6.31	4.57	5.88	6.90	3.72	3.5	.45	.36

Duckett Creek Sanitary District

SDR-35 x C900 BELL AND SPIGOT ADAPTERS
 Desn By: BSM App By: KLA Detail No. 19A
 Cld By: MDOB Date: 1-3-01

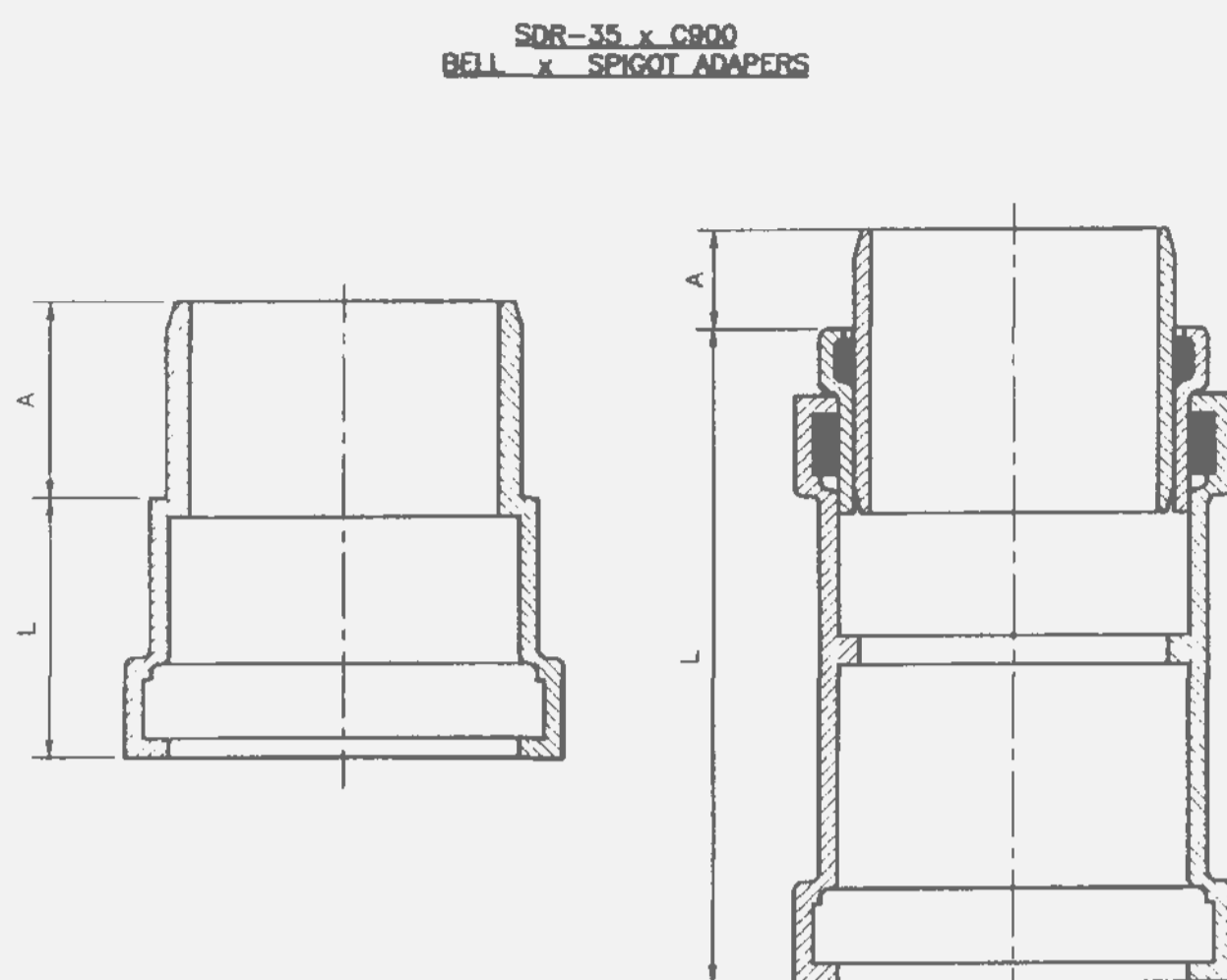

HARCO STYLE FABRICATED STYLE

SIZE	CATALOG NO.	A	L	STYLE
4"	335-040	3.2	10.0	FABRICATED
6"	335-060	2.9	3.5	HARCO
8"	335-080	4.0	12.5	FABRICATED

Duckett Creek Sanitary District

SDR-35 x C900 BELL AND SPIGOT SPECIAL 4", 6" & 8" ADAPTERS
 Desn By: BSM App By: KLA Detail No. 19B
 Cld By: MDOB Date: 1-3-01

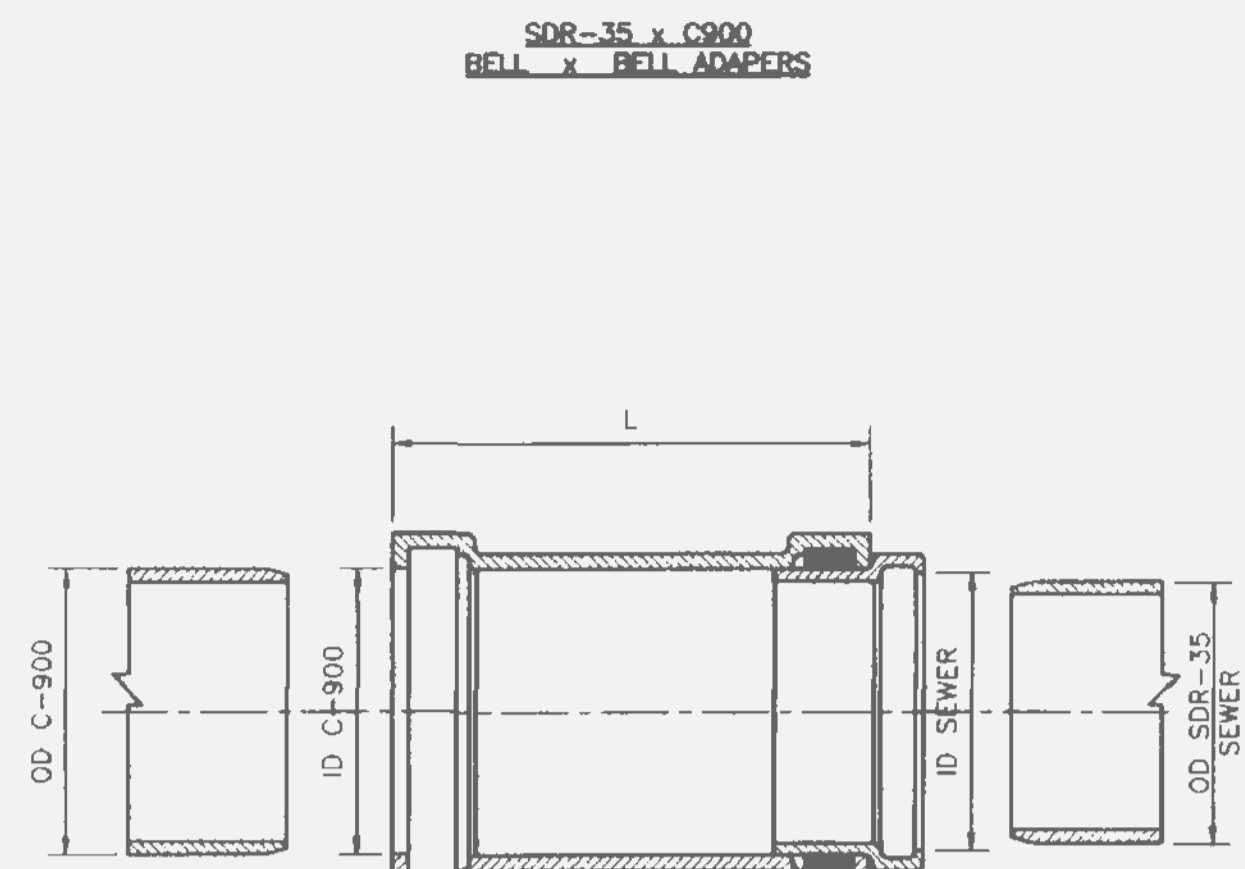

SIZE	CATALOG NO.	OD C900 SEWER	OD ID C900 SEWER	L	CTN QTY	CTN WT
4x4	337-040	4.80	4.215	4.86	4.25	10.0
6x6	337-060	6.90	6.275	6.96	6.32	11.13
8x8	337-080	9.05	8.400	9.13	8.45	12.50

Duckett Creek Sanitary District

SDR-35 x C900 BELL AND BELL 4", 6" & 8" ADAPTERS
 Desn By: BSM App By: KLA Detail No. 19C
 Cld By: MDOB Date: 1-3-01

PLASTIC SADDLE TEE OR WYE FITTING (SOLVENT WELD)

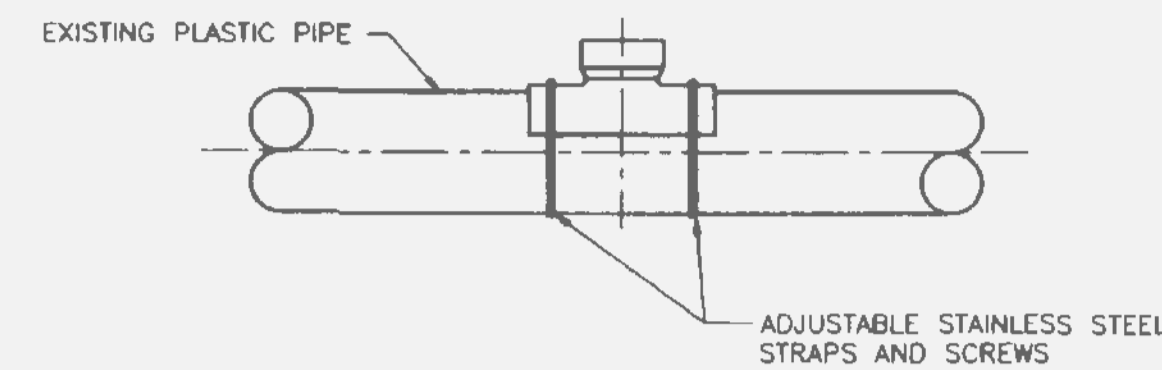

EXISTING PLASTIC PIPE
 ADJUSTABLE STAINLESS STEEL STRAPS AND SCREWS

WHEN CONNECTION TO A PLASTIC PIPE IS ALLOWED AND A CONNECTION IS LARGER THAN 6" IN DIAMETER, A SOLVENT WELD WYE OR TEE FITTING OF A SIMILAR MATERIAL MUST BE USED. (EXAMPLE: 10" x 8") THIS IS ACCOMPLISHED BY CAREFULLY CUTTING A HOLE WITH A SAW IN THE MAIN AT THE REQUIRED LOCATION AFTER CUTTING AND SHAPING THE HOLE TO THE SIZE OF THE FITTING. THE FOLLOWING STEPS SHOULD BE TAKEN.

- CLEAN AND DRY BOTH INSIDE THE SADDLE WYE SURFACE AND PIPE SURFACE TO BE SOLVENT CEMENTED.
- IMPORTANT: APPLY A LIBERAL, HEAVY COAT OF ONE-STEP SOLVENT CEMENT TO THE INSIDE SURFACE OF THE SADDLE WYE AND TO THE EXTERIOR WELDING SURFACE TO THE PIPE.
- WITHOUT DELAY, MATE THE SURFACES AND STRAP DOWN TIGHTLY. A BEAD OF SOLVENT SHOULD APPEAR AFTER THE SADDLE HAS BEEN STRAPPED DOWN TIGHTLY.
- USING A RAG OR PAPER TOWEL, WIPE BEAD AND ANY EXCESS SOLVENT CEMENT OFF PIPE AND SADDLE.
- ALLOW 30-60 MINUTES FOR SET-UP TIME BEFORE BACKFILLING. CURE TIME DEPENDS ON SIZE FIT OF MATERIALS BEING INSTALLED AND VARIOUS COLD DAMP CONDITIONS.
- DISCARD OLD SOLVENT IF IT BECOME JELLED OR LUMPY.
- A CLEAN, DRY BEDDING MATERIAL IS REQUIRED AROUND THE COMPLETED CONNECTION BEFORE BACKFILLING. THE BEDDING MATERIAL SHOULD BE ONE OF THE FOLLOWING:
 - 1 TO 3 CEMENT TO SAND MIX
 - "PRE-MIX" CONCRETE
 - DCSD APPROVED BEDDING FOR SANITARY SEWERS.

Duckett Creek Sanitary District

8" & LARGER CONNECTION TO PLASTIC MAIN
 Desn By: BSM App By: KLA Detail No. 20A
 Cld By: MDOB Date: 1-4-01

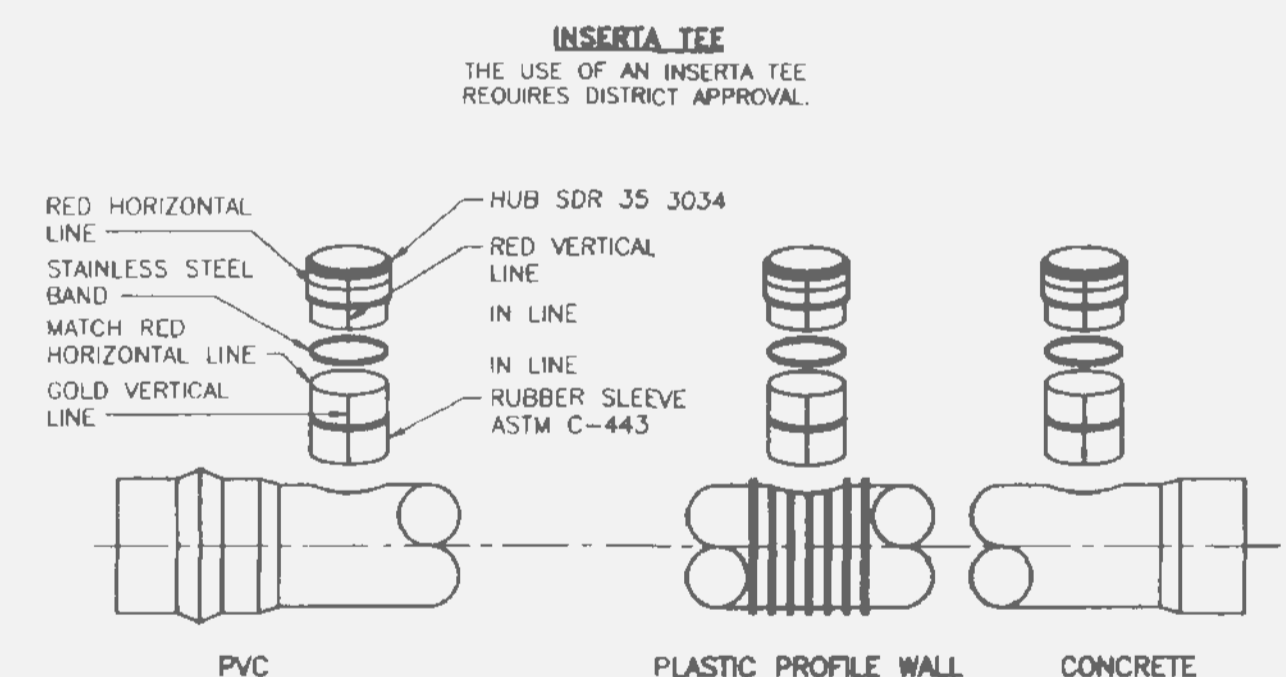

INSTALLATION PROCEDURE:

- CORE THE PROPER SIZE HOLE. TEE SIZE: 4" 6" 8" 10" 12" 15" BIT SIZE: 4 1/2" 6 1/2" 8 1/2" 10 1/4" 12 1/4" 15 1/4"
- INSERT THE RUBBER SLEEVE (1) IN THE CORED HOLE WITH THE GOLD VERTICAL LINE ON THE RUBBER SLEEVE (2) FACING TO THE SIDE OF THE MAIN LINE. THE UPPER SEGMENT SHOULD BE ON TOP OF THE WALL OR RIB AND THE LOWER SEGMENT (PVC, PROFILE WALL, AND POLYETHYLENE PIPE ONLY) SHOULD BE ON THE INSIDE OF THE PIPE.
- APPLY THE INSERTA TEE SOLUTION SUPPLIED TO THE INSIDE OF THE RUBBER SLEEVE AND TO THE OUTSIDE OF THE PVC HUB ADAPTER. CAUTION - DO NOT USE AN OIL BASED LUBRICANT!
- PLACE THE PVC HUB ADAPTER (3) INTO THE RUBBER SLEEVE. MAKE SURE THAT THE RED VERTICAL LINE (4) ON THE PVC HUB ADAPTER IS IN LINE WITH THE GOLD VERTICAL LINE (2) ON THE RUBBER SLEEVE.
- PLACE THE 2x4 BOARD ONTO THE TOP OF THE PVC HUB ADAPTER.
- THE RED HORIZONTAL LINE (5) AT THE TOP OF THE HUB ADAPTER IS A DEPTH MARK. THIS TELLS THE INSTALLER HOW FAR TO DRIVE THE ADAPTER INTO THE RUBBER SLEEVE. DRIVE THE PVC HUB ADAPTER INTO THE RUBBER SLEEVE TO WHERE THE HORIZONTAL RED LINE (5) ON THE PVC HUB ADAPTER (3) MEETS THE TOP OF THE RUBBER SLEEVE (2).
- PLACE THE STAINLESS STEEL BAND (7) AROUND THE TOP OF THE RUBBER SLEEVE AND TIGHTEN DOWN.
- INSTALL PIPE IN NORMAL MANNER.

Duckett Creek Sanitary District

INSERTA TEE DETAILS AND SPECIFICATIONS
 Desn By: BSM App By: KLA Detail No. 20B
 Cld By: MDOB Date: 1-4-01

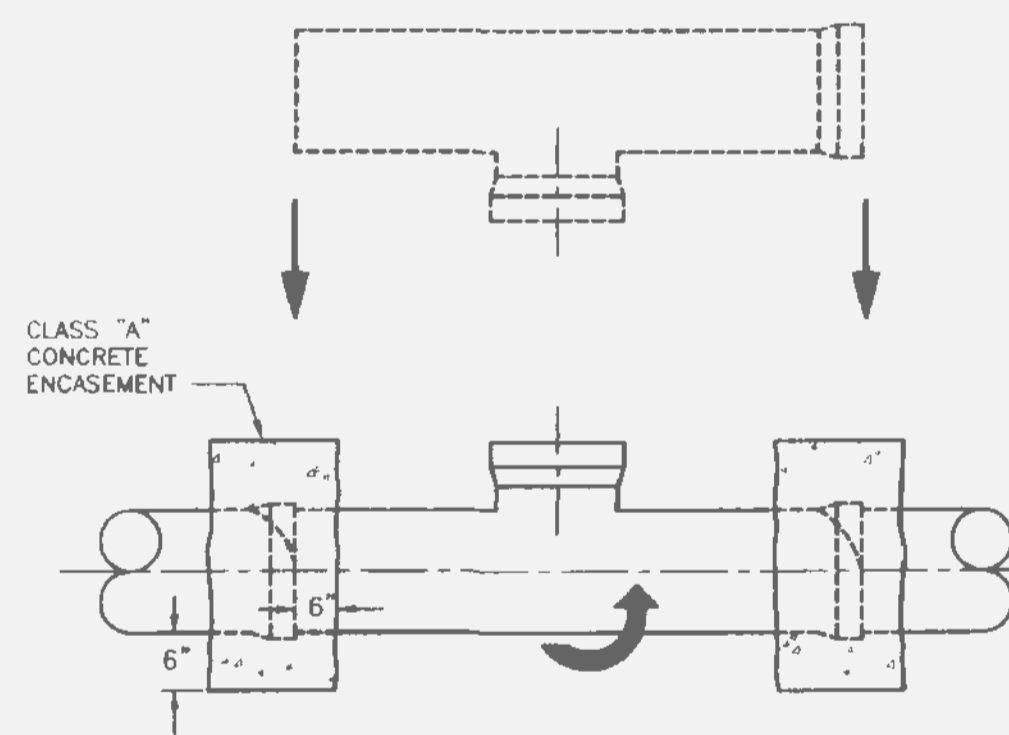

NOTES:

- WHEN A CONNECTION IS ALLOWED LARGER THAN 6" DIAMETER A SADDLE MAY BE USED IF THE I.D. OF THE CONNECTION PIPE IS NOT GREATER THAN ONE HALF (1/2) OF THE I.D. OF THE MAIN SEWER. (EXAMPLE: 24" x 10")
- IF THE I.D. OF THE CONNECTION PIPE IS GREATER THAN ONE HALF (1/2) THE I.D. OF THE MAIN SEWER THE WYE OR TEE MUST BE "ROLLED IN". (EXAMPLE: 15" x 8")
- THIS IS ACCOMPLISHED BY BREAKING AWAY AND REMOVING ONE SECTION OF PIPE. THE TOP HALF OF THE BELL ON THE PIPE LYING ADJACENT TO THE GAP IS CAREFULLY BROKEN OFF. THE TOP HALF OF THE BELL ON THE MAIN REPLACEMENT SECTION (WITH A "TEE" OR "WYE") FITTING IS ALSO BROKEN OFF. THE REPLACEMENT PIPE IS THEN PLACED IN THE LINE GAP WITH THE STUB POINTED IN THE WRONG DIRECTION. THE BROKEN BELLS ON THE REPLACEMENT AND ADJOINING PIPE MAKE IT POSSIBLE FOR THE REPLACEMENT SECTION TO FIT INTO THE SEWER LINE WITHOUT DISTURBING THE ADJOINING PIPE SECTIONS. THE REPLACEMENT SECTION IS THEN ROTATED TO THE DESIRED POSITION AND THE BROKEN BELLS ARE ENCASED WITH A 6" CLASS "A" CONCRETE ENCASEMENT.
- ID OF MAIN SEWER SHALL NOT BE DECREASED BY A ROLL-IN CONNECTION.

Duckett Creek Sanitary District

"ROLL-IN" (FOR EXISTING CLAY OR CONCRETE PIPE)
 Desn By: BSM App By: KLA Detail No. 21
 Cld By: MDOB Date: 1-5-01

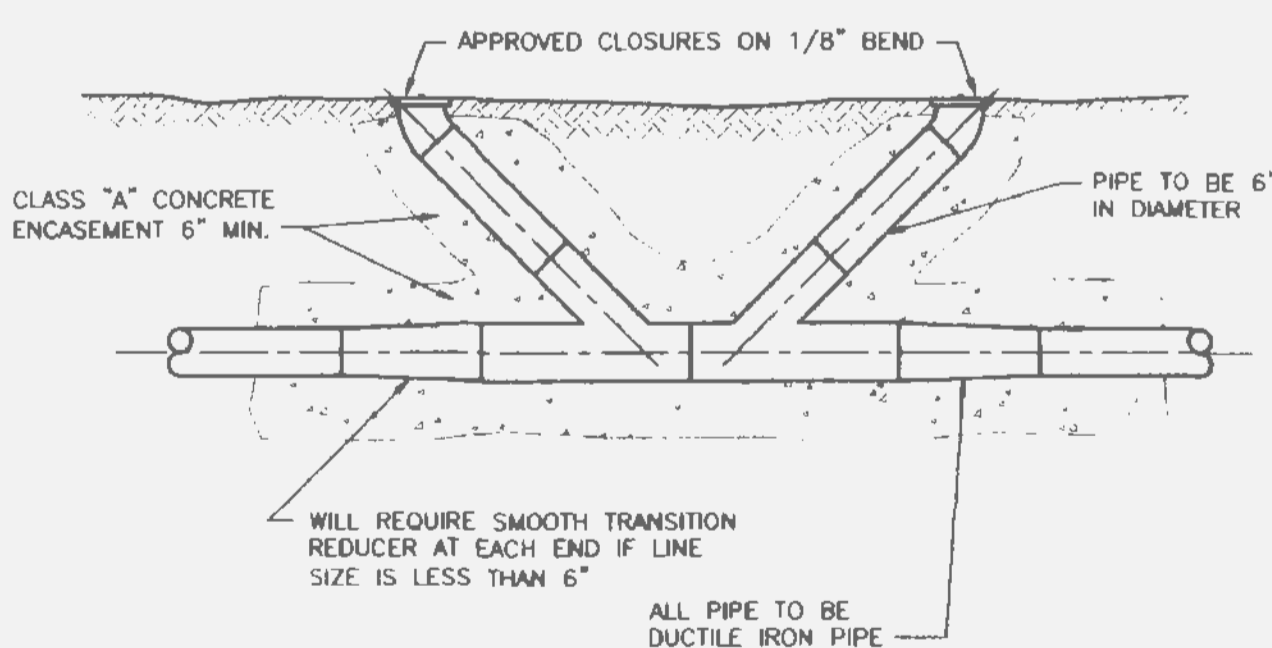

1800' MAXIMUM SPACING

Duckett Creek Sanitary District

FORCE MAIN CLEANOUT (6" DIA. & SMALLER)
 Desn By: BSM App By: KLA Detail No. 22
 Cld By: MDOB Date: 1-5-01

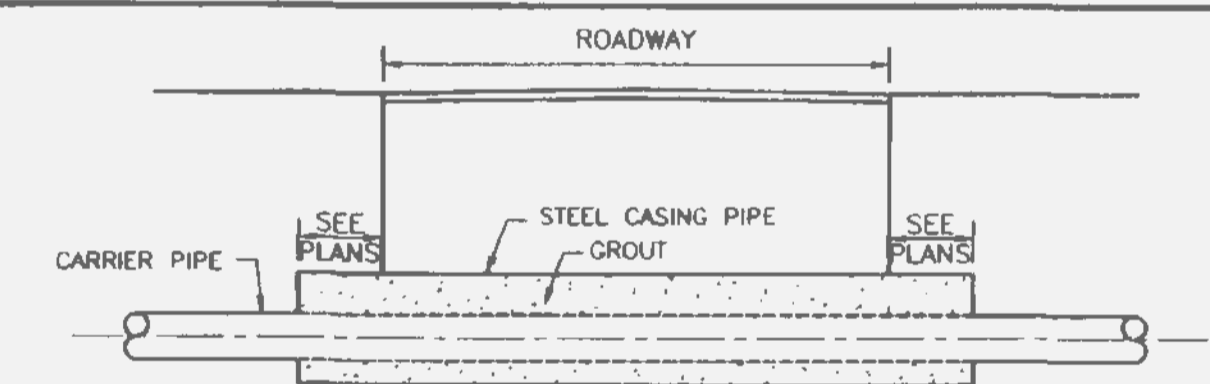

NOTES:

- INSIDE DIAMETER OF CASING PIPE TO BE MINIMUM OF 4" GREATER THAN COUPLING DIAMETER OF CARRIER PIPE.
- ENCASEMENTS TO BE INSTALLED UNDER THE ROAD BY MEANS OF JACKING IT THROUGH, OR BY DRY BORING A HOLE THAT WILL RECEIVE THE CASING WITH A SNUG FIT.
- THE OUTSIDE DIAMETER OF THE CASING SHALL NOT BE LESS THAN, NOR MORE THAN ONE INCH GREATER THAN THE BORED HOLE.
- THE ANNULAR SPACE BETWEEN THE CASING PIPE AND THE BORED HOLE SHALL BE FILLED WITH GROUT.

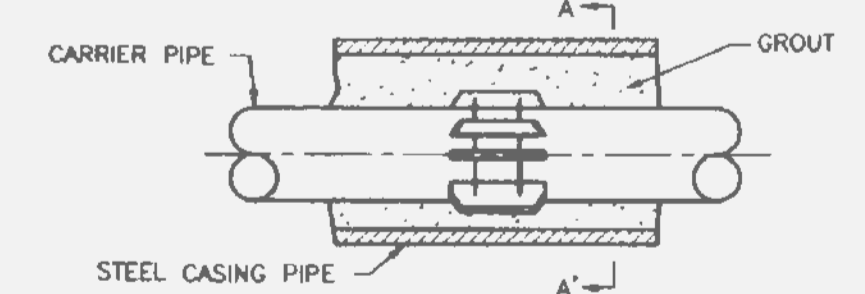

SUPPORT OF CARRIER PIPE OR FORCE MAIN IN CASING

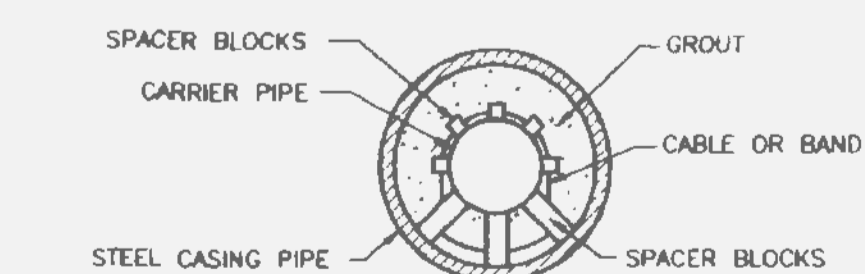

SECTION A-A'

Duckett Creek Sanitary District

ROADWAY BORING DETAIL
 Desn By: BSM App By: KLA Detail No. 23
 Cld By: MDOB Date: 1-5-01

USER: Taylor, Stuart TAB: DETAILS B DATE: May 22, 2014 - 2:29:40 PM Drawing: S:\0085\Job601313\13-108\CDSD-DWG\C-04A(P-PMSE)01.dwg C-04A(P-PMSE)01.dwg PWT:DETAILS.dwg

DEVELOPER/OWNER: **FULTE GROUP**
1707 CHESTERFIELD AIRPORT RD. STE 120
CHESTERFIELD, MO 63005
PHONE: (636) 537-7129

CITY COMMENTS: 3 2/27/14
 CITY COMMENTS: 2 3/2/14
 CITY COMMENTS: 1 3/2/14
 DATE: NO

THE PROFESSIONAL ENGINEER'S SIGNATURE AND PERSONAL SEAL APPEAR HEREON. ASSUMES RESPONSIBILITY ONLY FOR WHAT APPEARS ON THIS PAGE, AND DISCLAIMS SPECIFICATIONS, ESTIMATES, REVIEWS, OR OTHER DOCUMENTS OR INSTRUMENTS NOT SEALED BY THE UNDERSIGNED PROFESSIONAL ENGINEER, OR INTENDED TO BE USED FOR ANY PART OR PARTS OF THE PROJECT TO WHICH THIS PAGE RELATES.

JOHN F. HARSHBARGER
 PROFESSIONAL ENGINEER
 LICENSE NO. E-29716

CIVIL ENGINEERS REGISTERED PROFESSIONAL ENGINEERS
 JOHN F. HARSHBARGER
 LICENSE NO. E-29716

PRESTON WOODS
PHASE 7
IMPROVEMENT PLANS
 PRESTON WOODS LANE
 OTTAWA, MO 63366

SANITARY SEWER DETAILS

+ ST. CHARLES
 1520 S. Firm Street
 Suite 307
 St. Charles, MO 63003
 636.976.7528 (r/f)

COLE
 CIVIL ENGINEERING / SURVEYING / PLANNING / LANDSCAPE ARCHITECTURE
 Cole & Associates, Inc.

DESIGN/CALC BY: MTS
 DRAWN BY: MTS
 CHECKED BY: JFH
 DRAWING SCALE: -
 DATE: 01/07/2013
 Job Number: 13-0109
 Sheet Number: C9.8