

CROSS SECTION	CONDITION			SIGN	
	DIFFERENTIAL	TIME	TREATMENT	MAINLINE (1)	SIDE ROAD (2)
EDGE DROP-OFF 1:12H SLOPE OR FLATTER	PAYMENT EDGE DIFFERENTIAL 7' 4" TO 5' 3"	NON-WORKING HOURS	WEDGE SLOPE TO 1:12H ON FLATTER	NO SIGNS REQUIRED	NO SIGNS REQUIRED
		WORKING HOURS	NO EDGE TREATMENT REQUIRED	NO SIGNS REQUIRED	NO SIGNS REQUIRED
1:12H SLOPE OR FLATTER	PAYMENT EDGE DIFFERENTIAL 7' 4" TO 5' 3"	NON-WORKING HOURS	WEDGE SLOPE TO 1:12H ON FLATTER	NO SIGNS REQUIRED	NO SIGNS REQUIRED
		WORKING HOURS	NO EDGE TREATMENT REQUIRED	NO SIGNS REQUIRED	NO SIGNS REQUIRED
1:12H SLOPE OR FLATTER	PAYMENT EDGE DIFFERENTIAL 5' 3"	NON-WORKING HOURS	WEDGE SLOPE TO 1:12H ON FLATTER	NO SIGNS REQUIRED	NO SIGNS REQUIRED
		WORKING HOURS	DELINEATE DIFFERENTIAL WITH CHANNELIZERS	NO SIGNS REQUIRED	NO SIGNS REQUIRED
10' MIN. ALL HEIGHTS	ANY PAYMENT EDGE OR LANE LINE DIFFERENTIAL	NON-WORKING HOURS	WEDGE SLOPE TO 1:12H ON FLATTER	NO SIGNS REQUIRED	NO SIGNS REQUIRED
		WORKING HOURS	DELINEATE DIFFERENTIAL WITH CHANNELIZERS	NO SIGNS REQUIRED	NO SIGNS REQUIRED
LANE LINE DIFFERENTIAL 2' 2"	LANE LINE DIFFERENTIAL 2' 2"	NON-WORKING HOURS	NO EDGE TREATMENT REQUIRED	NO SIGNS REQUIRED	NO SIGNS REQUIRED
		WORKING HOURS	DELINEATE DIFFERENTIAL WITH CHANNELIZERS	NO SIGNS REQUIRED	NO SIGNS REQUIRED

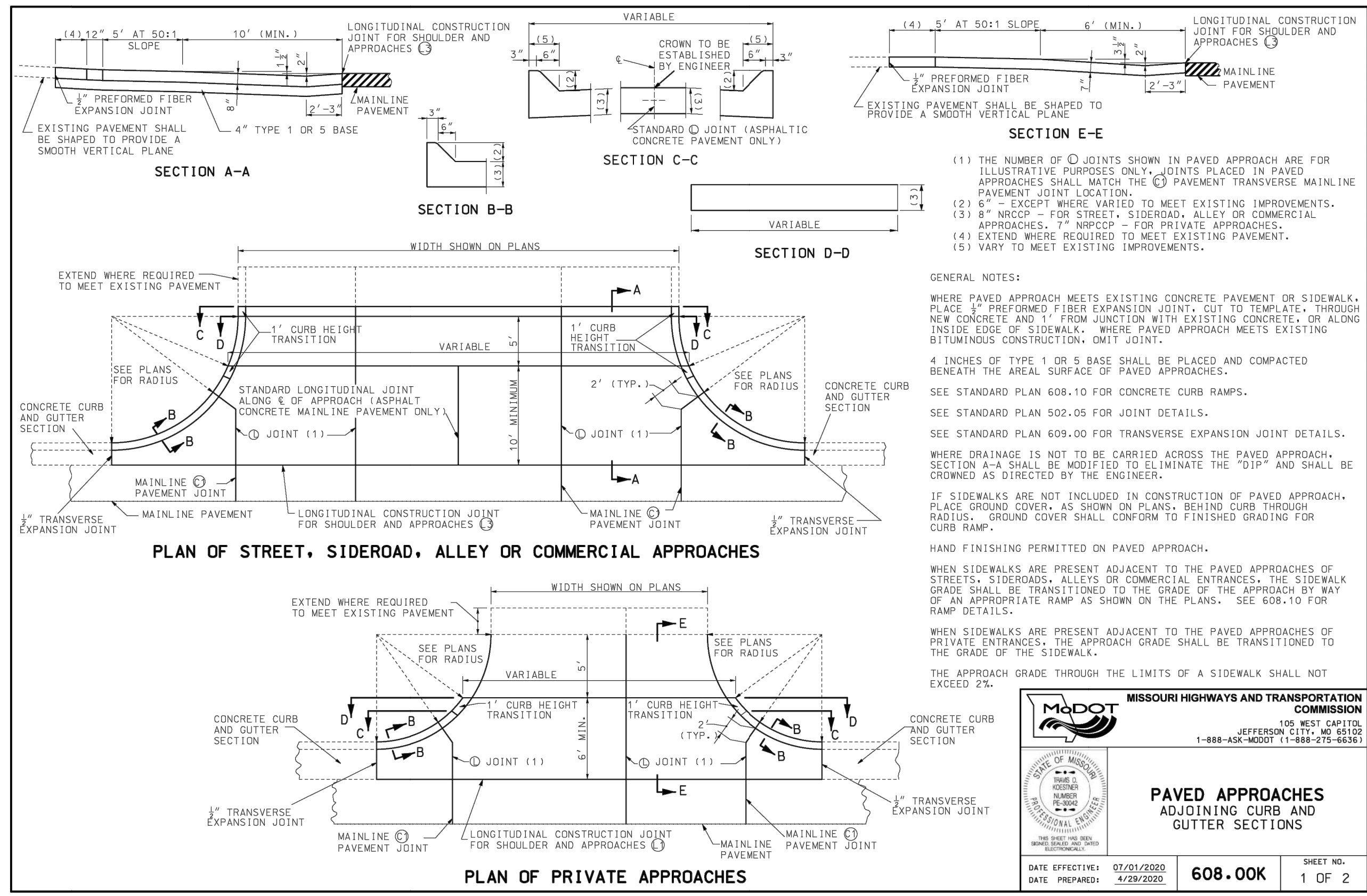
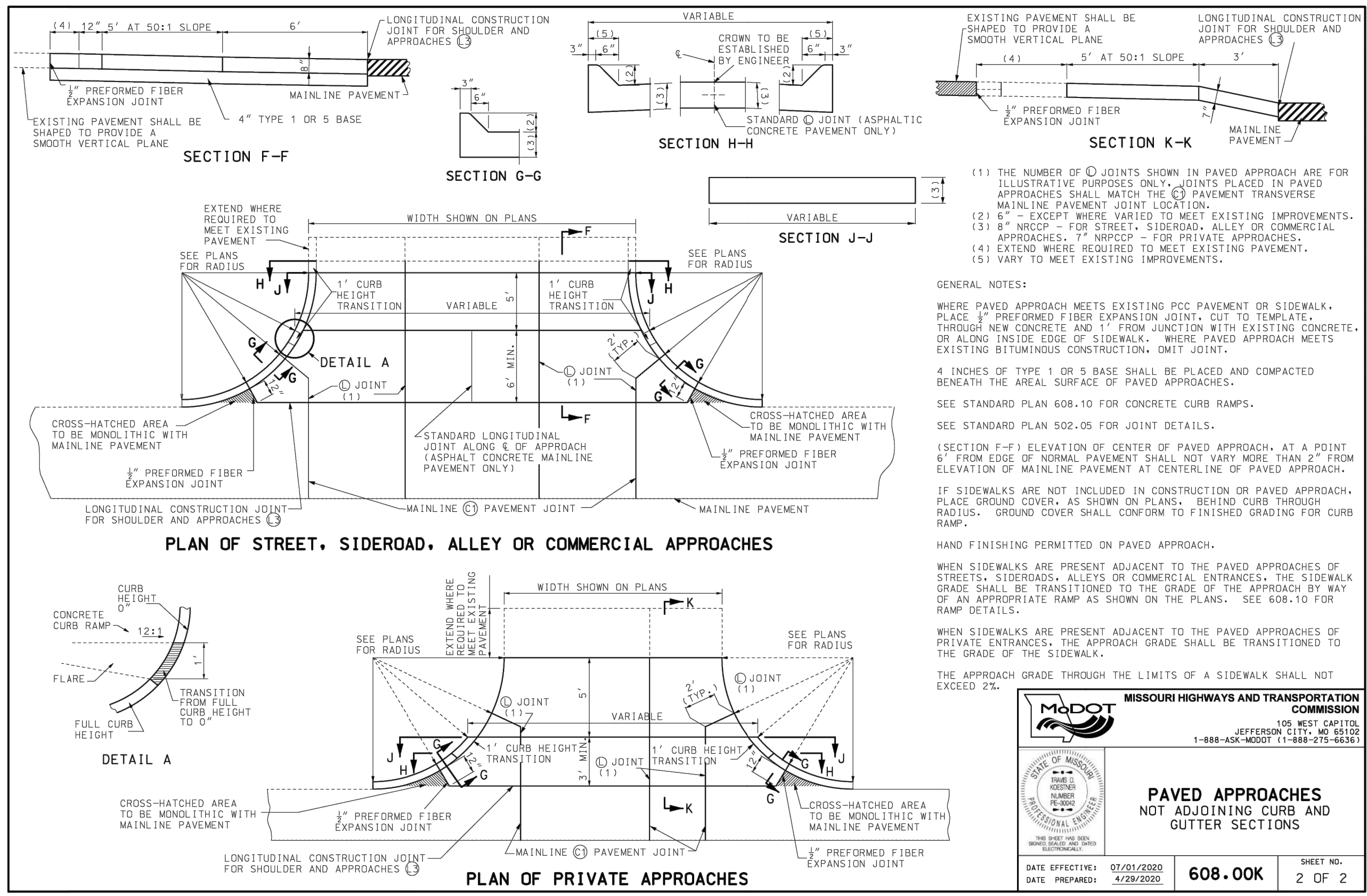
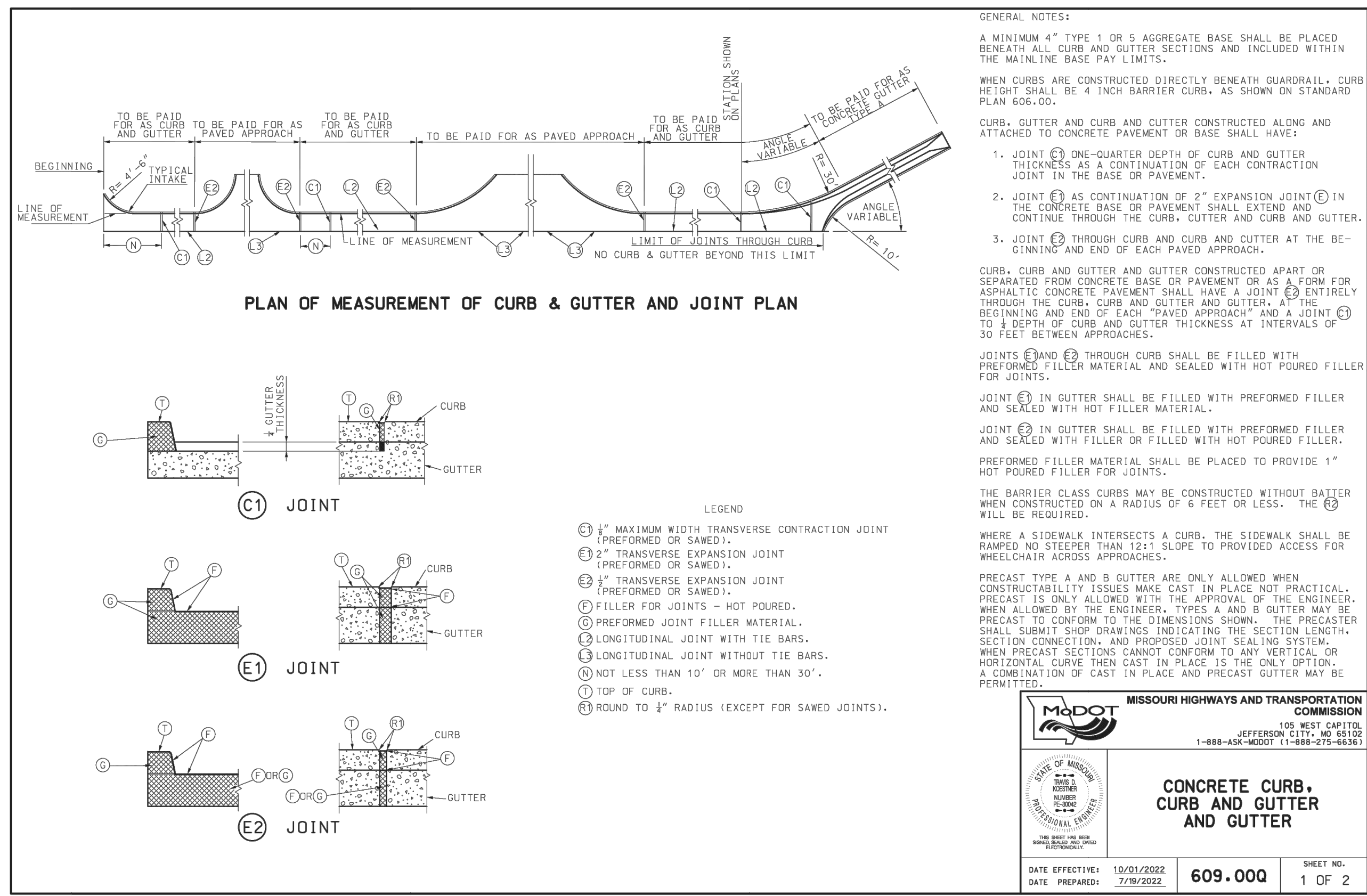
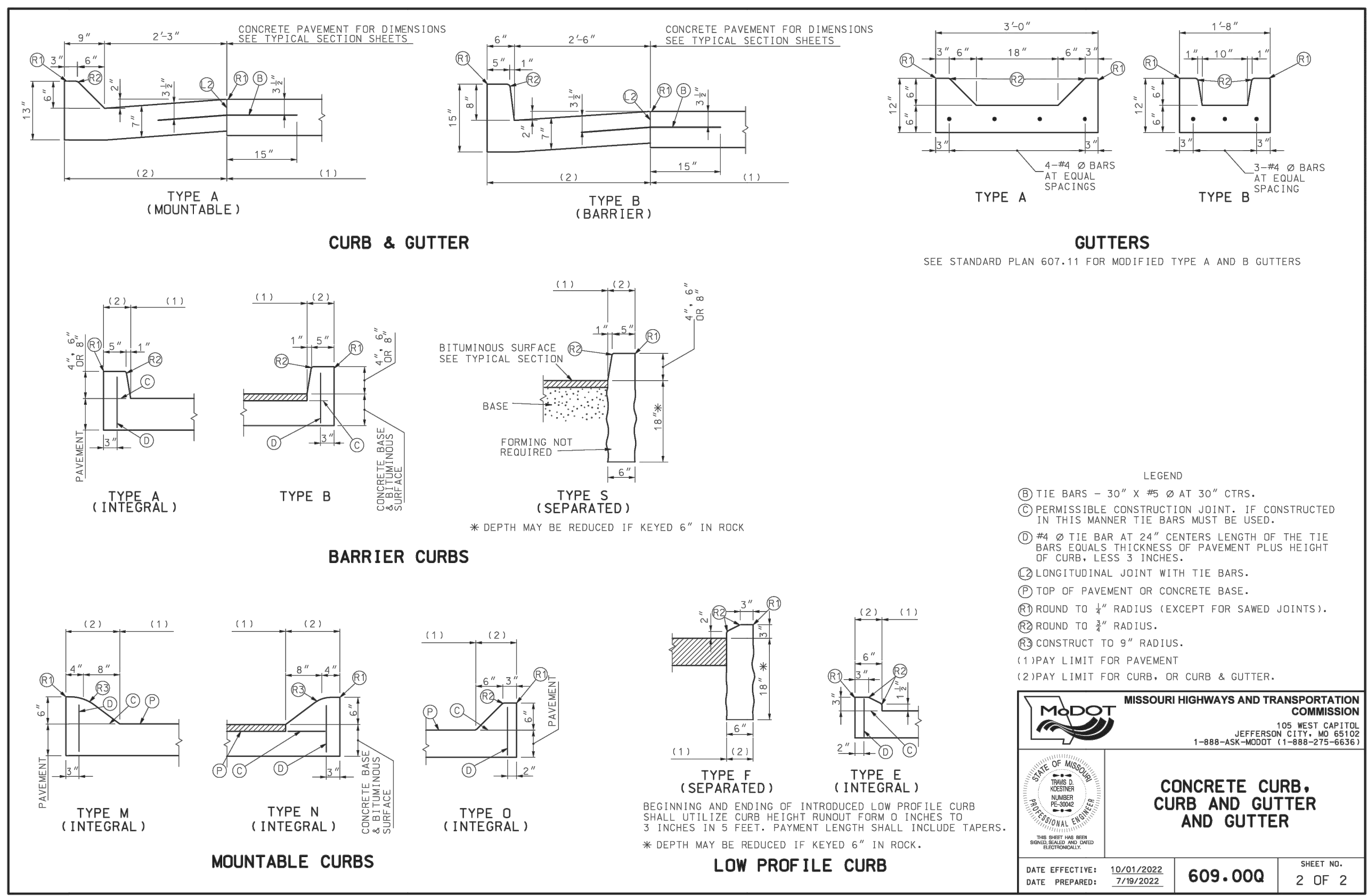
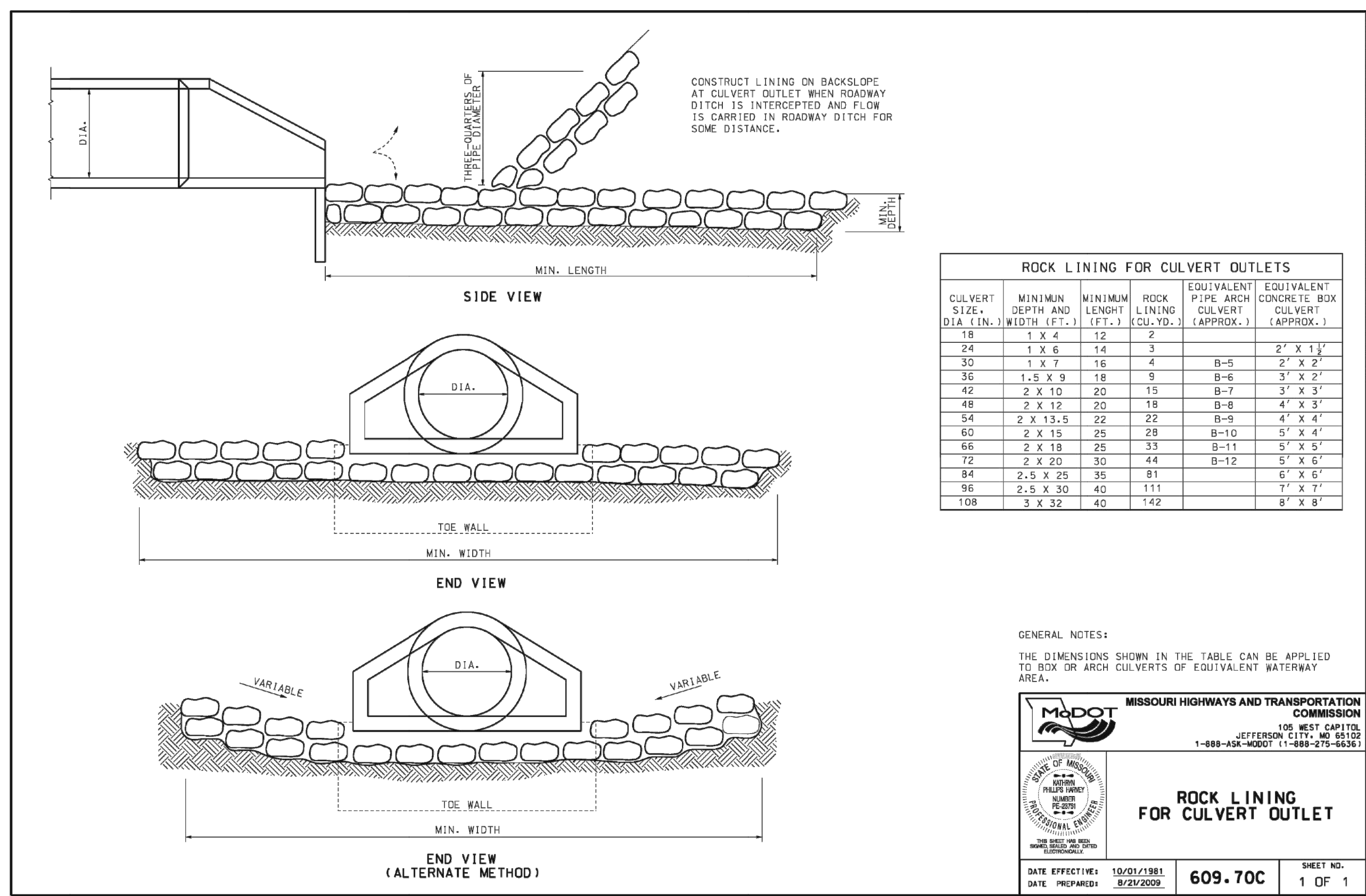

hdesigngroup
 architecture + design

5039 S National Avenue | Springfield, MO 65810 | 417.887.6595

OWNER
 CITY OF OFALLON
 100 NORTH MAIN STREET
 OFALLON, MO 63366
 636.379.5590

PROJECT TEAM
 CIVIL ENGINEER
 PREMIER DESIGN GROUP
 100 MIDLAND PARK DRIVE
 WENTZVILLE, MO 63385
 314.925.7444

MAINTENANCE CONSULTANT
 HDR ENGINEERING, INC.
 17725 KATY FREEWAY SUITE 102
 HOUSTON, TX 77094
 813.900.2700

STRUCTURAL ENGINEER
 METTMEYER ENGINEERING
 2225 W CHESTERFIELD BLVD., SUITE 300
 SPRINGFIELD, MO 65807
 417.890.8002

MEP ENGINEER
 HENDERSON ENGINEERS, INC.
 8345 LENEXA DR., #300
 LENEXA, KS 66214
 913.742.5000

REVISIONS

NO.	DESCRIPTION	DATE
1	ADDENDUM #01	10/5/2023

PROJECT NO: 2207920
 DATE: 9-15-2023
 DRAWN BY: A. JONES
 REVIEWED BY: M. FOGARTY

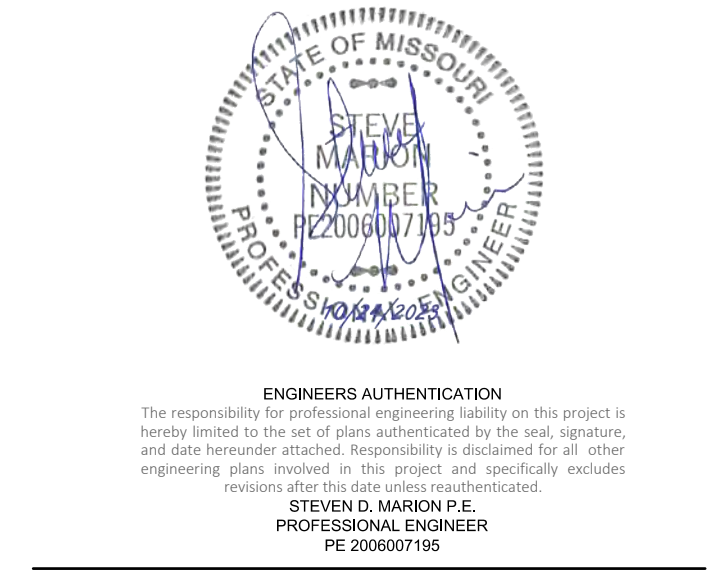

PROFESSIONAL SEAL

PROJECT TITLE
 O'FALLON PUBLIC WORKS FACILITY

PROJECT ADDRESS:
 1101 OLD E TERRA LANE
 O'FALLON, MO 63366

MODOT CONSTRUCTION DETAILS

608.00K
 SHEET NO. 1 OF 2

C-702