

NEW INSIDE DROP ON EXISTING MANHOLE FOR 8 INCH TO 12 INCH
 METROPOLITAN ST. LOUIS SEWER DISTRICT
 Standard Details of Sewer Construction
 Dr. ROW/SAM Ch. J.C.K. 2000 SHEET 18

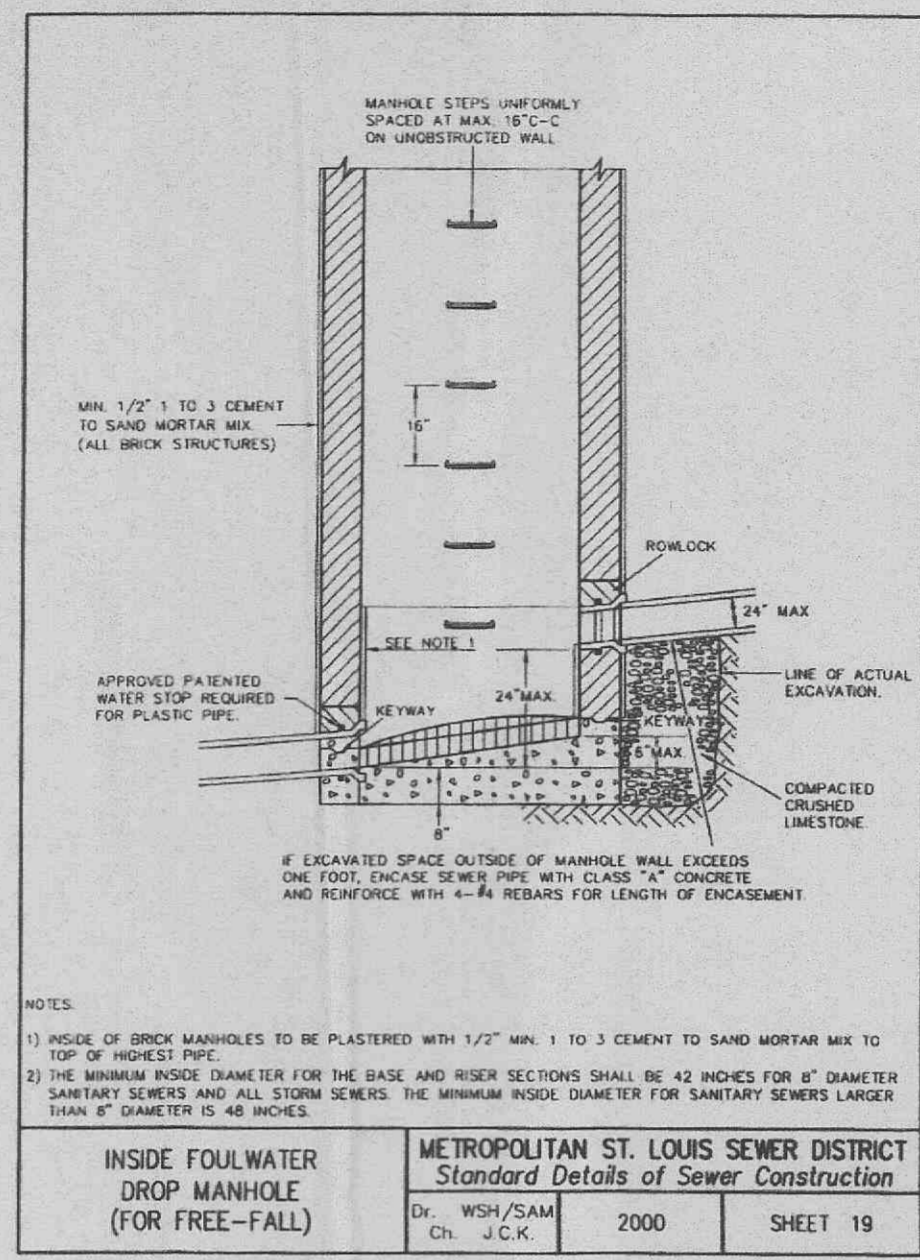

INSIDE FOULWATER DROP MANHOLE (FOR FREE-FALL)
 METROPOLITAN ST. LOUIS SEWER DISTRICT
 Standard Details of Sewer Construction
 Dr. WSH/SAM Ch. J.C.K. 2000 SHEET 19

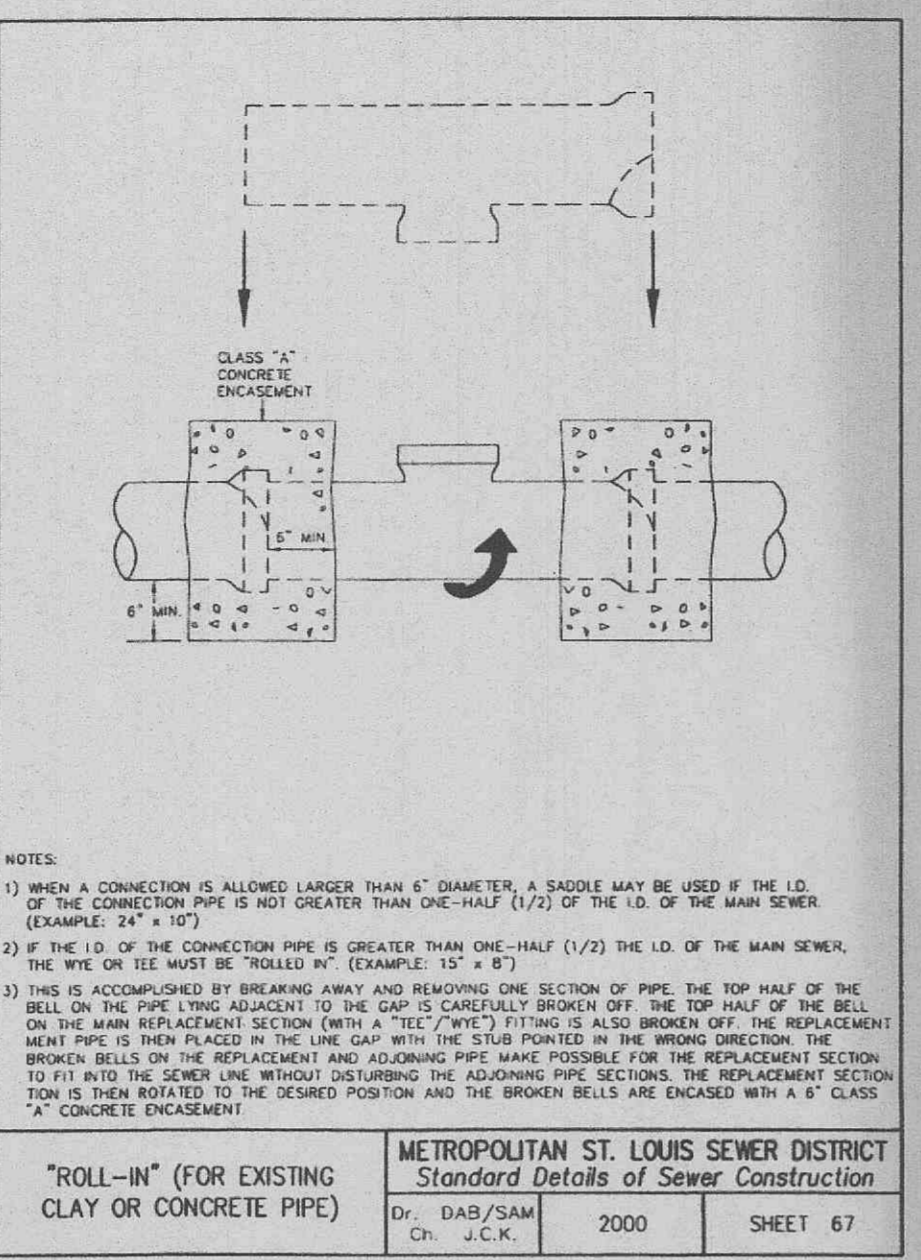

"ROLL-IN" (FOR EXISTING CLAY OR CONCRETE PIPE)
 METROPOLITAN ST. LOUIS SEWER DISTRICT
 Standard Details of Sewer Construction
 Dr. DAB/SAM Ch. J.C.K. 2000 SHEET 17

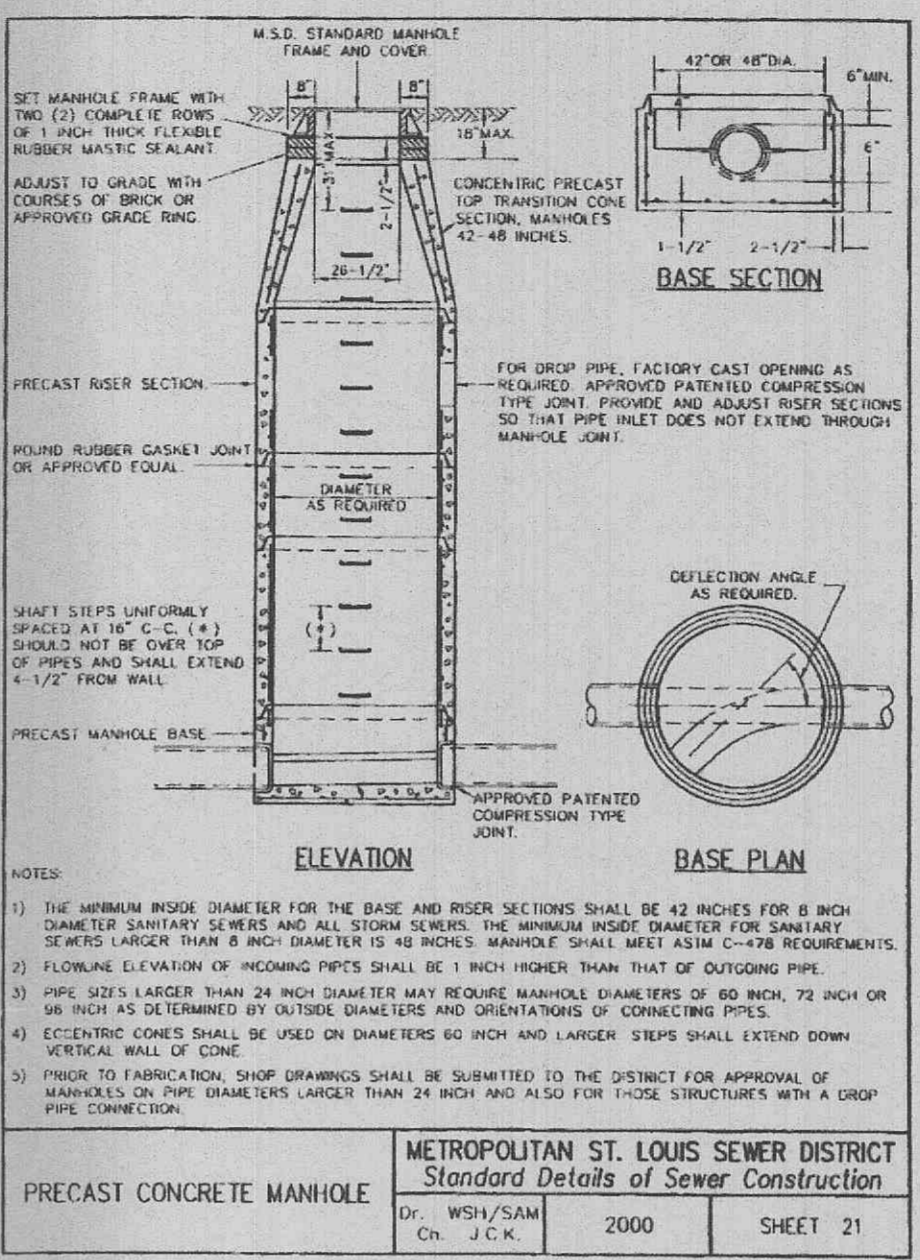

PRECAST CONCRETE MANHOLE
 METROPOLITAN ST. LOUIS SEWER DISTRICT
 Standard Details of Sewer Construction
 Dr. WSH/SAM Ch. J.C.K. 2000 SHEET 21

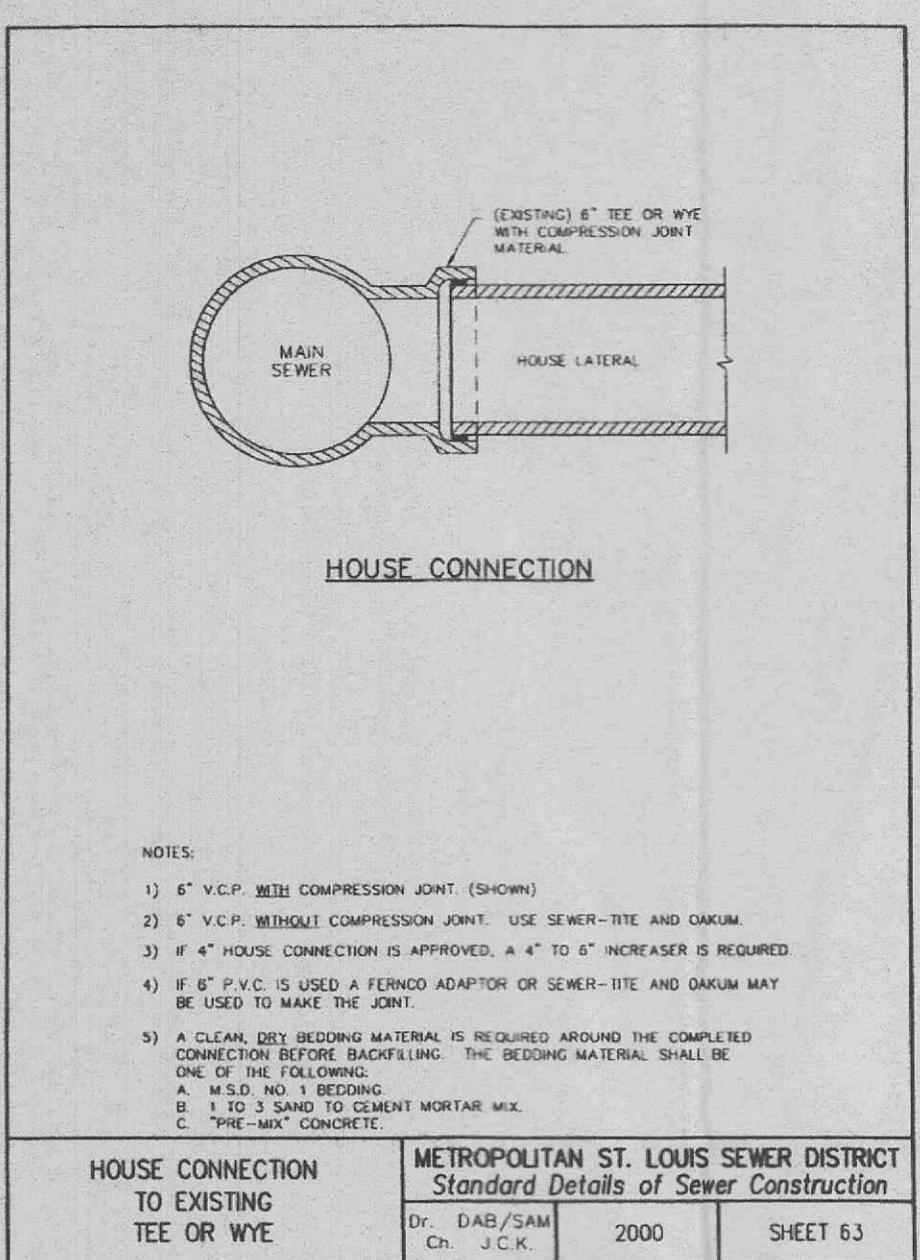

HOUSE CONNECTION TO EXISTING TEE OR WYE
 METROPOLITAN ST. LOUIS SEWER DISTRICT
 Standard Details of Sewer Construction
 Dr. DAB/SAM Ch. J.C.K. 2000 SHEET 63

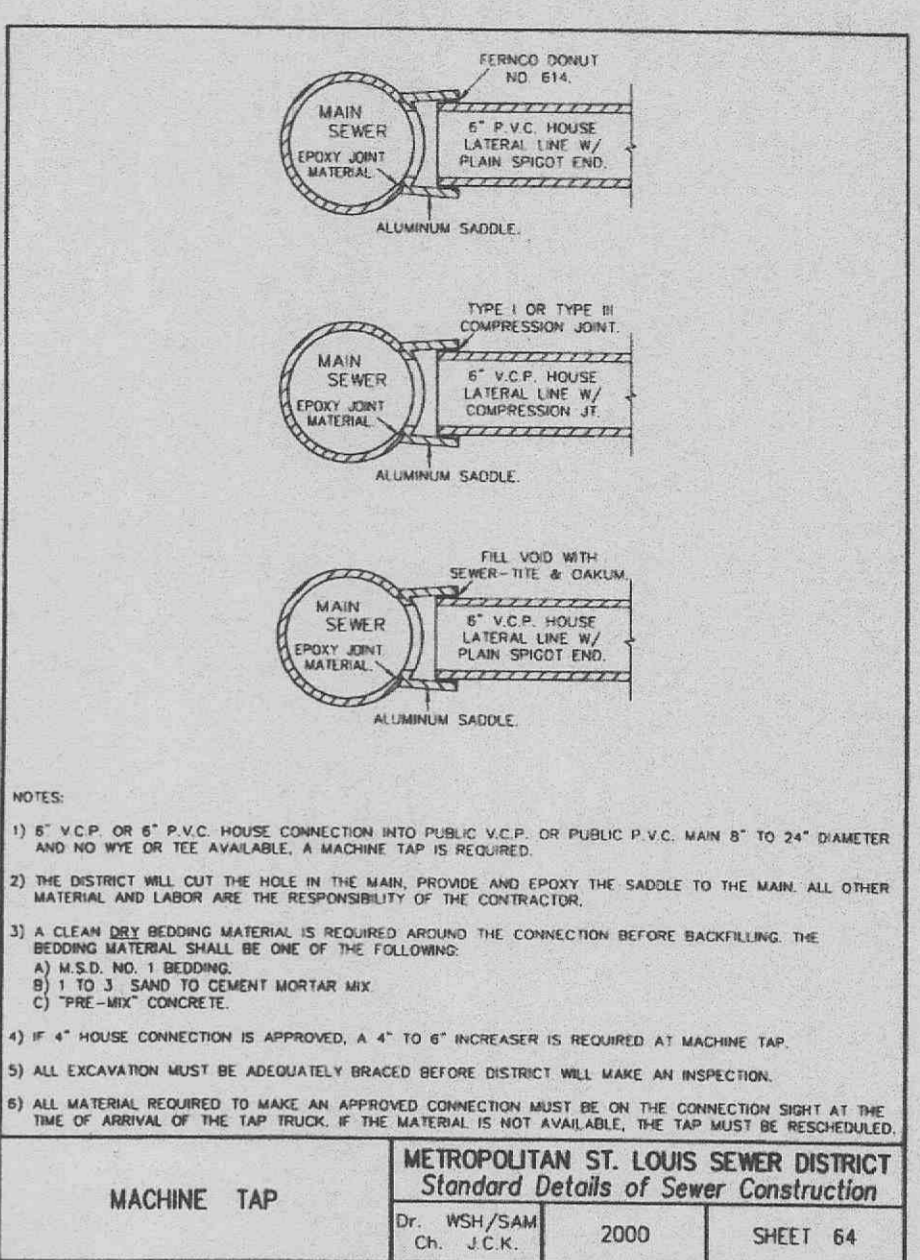

MACHINE TAP
 METROPOLITAN ST. LOUIS SEWER DISTRICT
 Standard Details of Sewer Construction
 Dr. WSH/SAM Ch. J.C.K. 2000 SHEET 64

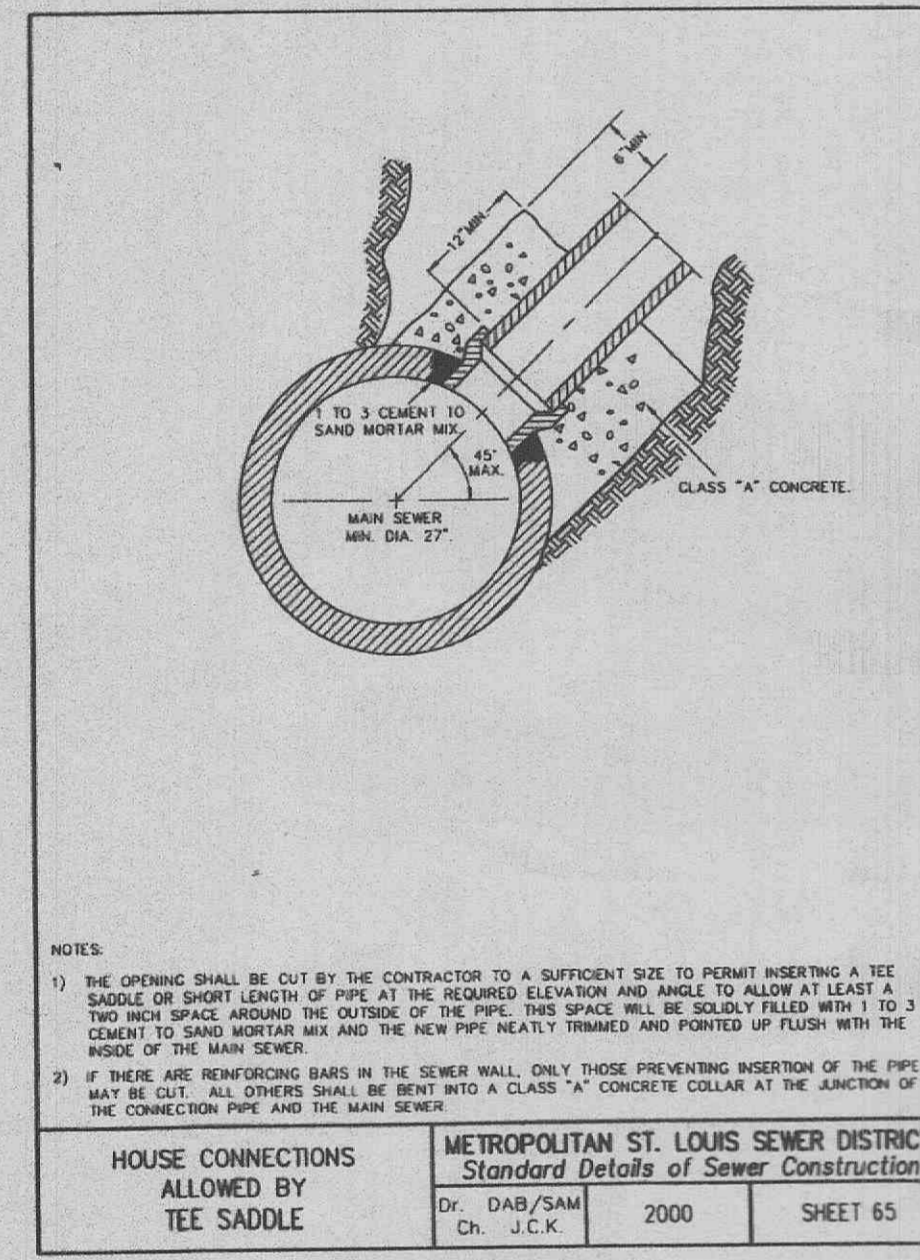

HOUSE CONNECTIONS ALLOWED BY TEE SADDLE
 METROPOLITAN ST. LOUIS SEWER DISTRICT
 Standard Details of Sewer Construction
 Dr. DAB/SAM Ch. J.C.K. 2000 SHEET 65

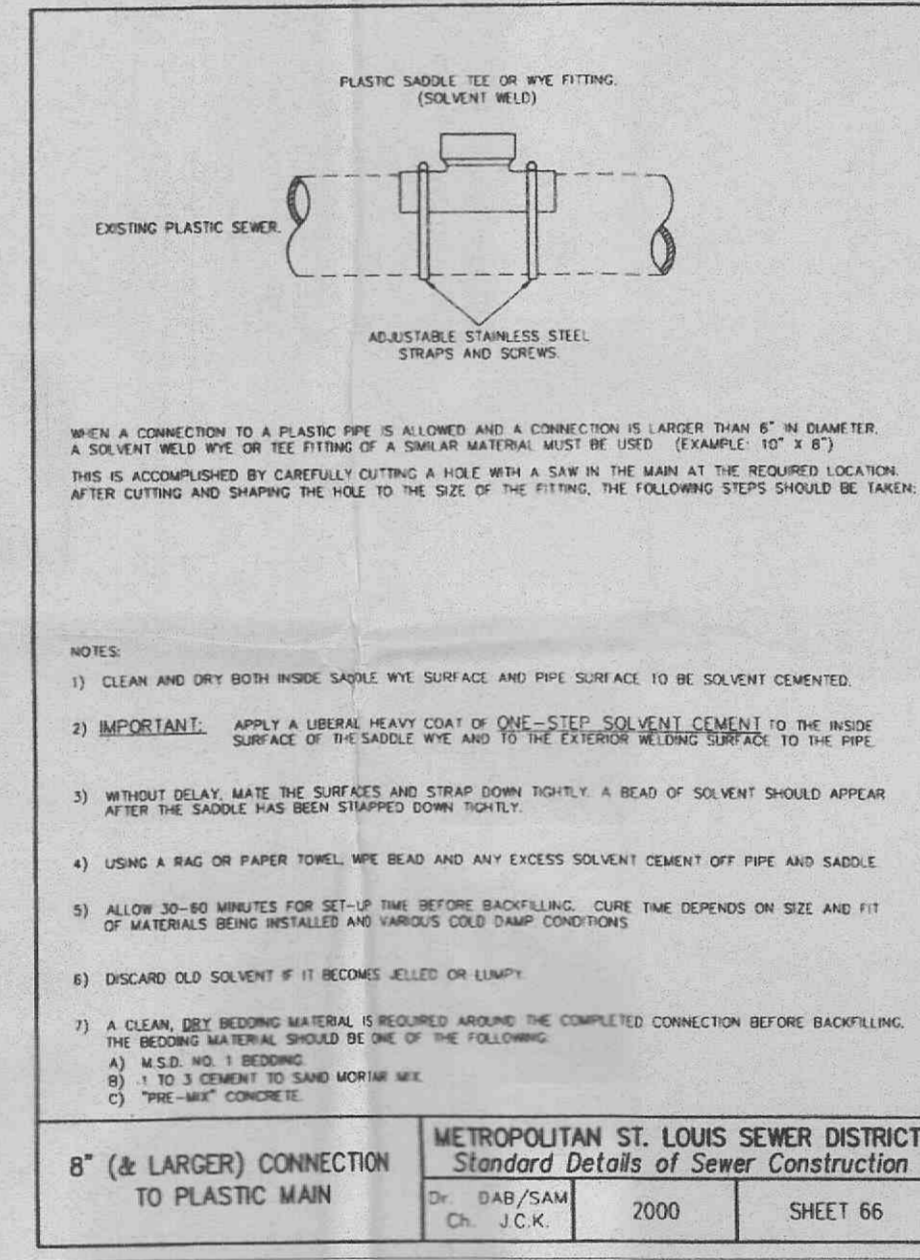

8" (& LARGER) CONNECTION TO PLASTIC MAIN
 METROPOLITAN ST. LOUIS SEWER DISTRICT
 Standard Details of Sewer Construction
 Dr. DAB/SAM Ch. J.C.K. 2000 SHEET 66

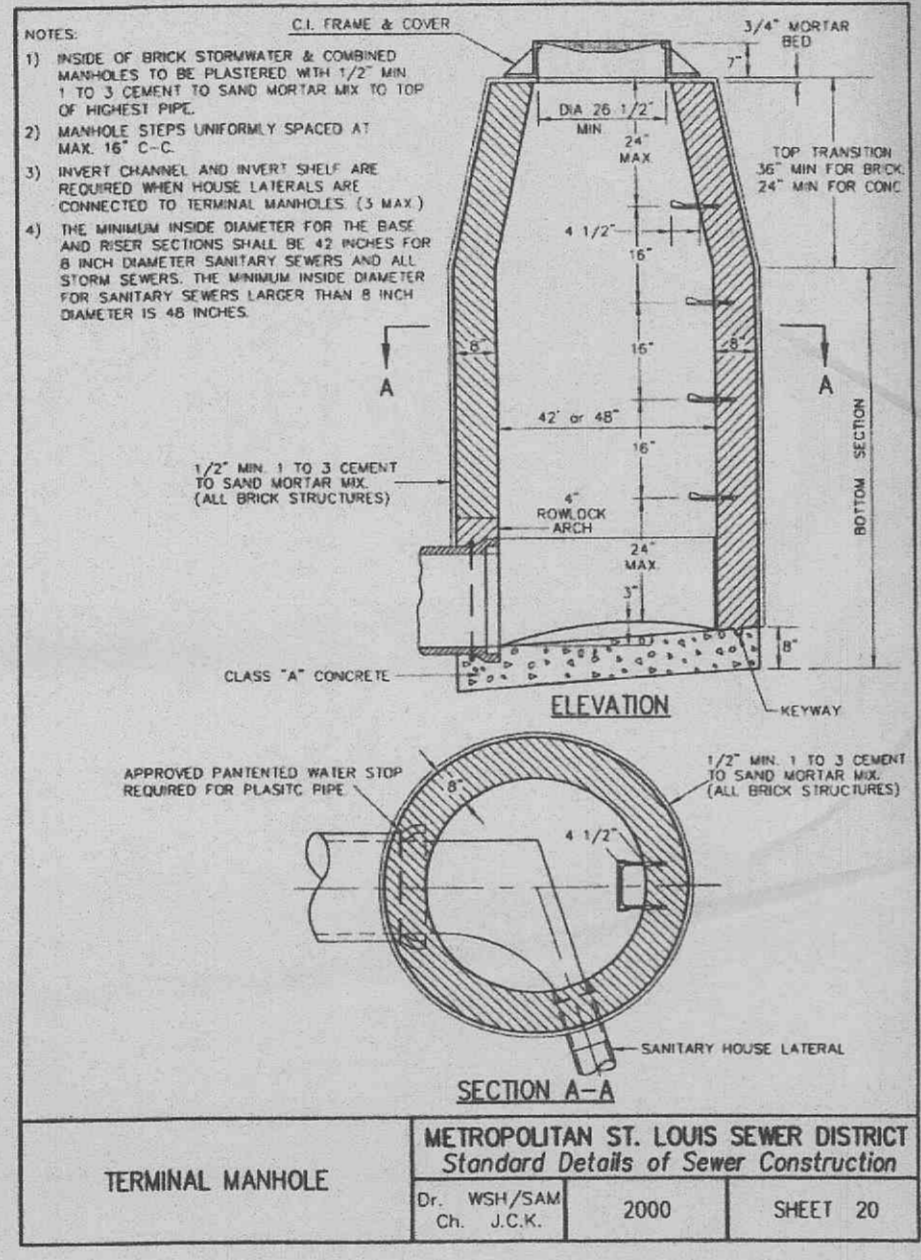

TERMINAL MANHOLE
 METROPOLITAN ST. LOUIS SEWER DISTRICT
 Standard Details of Sewer Construction
 Dr. WSH/SAM Ch. J.C.K. 2000 SHEET 20

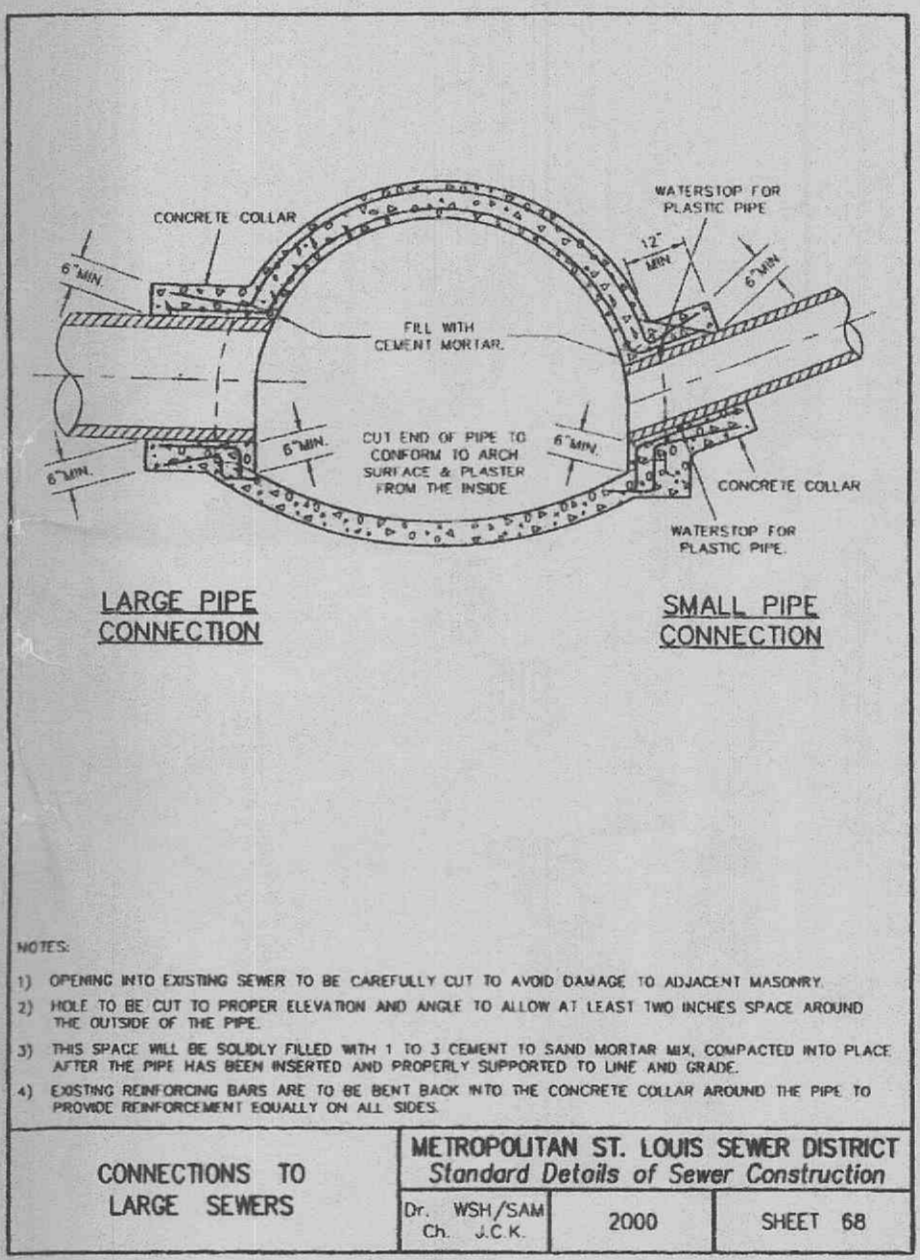

CONNECTIONS TO LARGE SEWERS
 METROPOLITAN ST. LOUIS SEWER DISTRICT
 Standard Details of Sewer Construction
 Dr. WSH/SAM Ch. J.C.K. 2000 SHEET 68

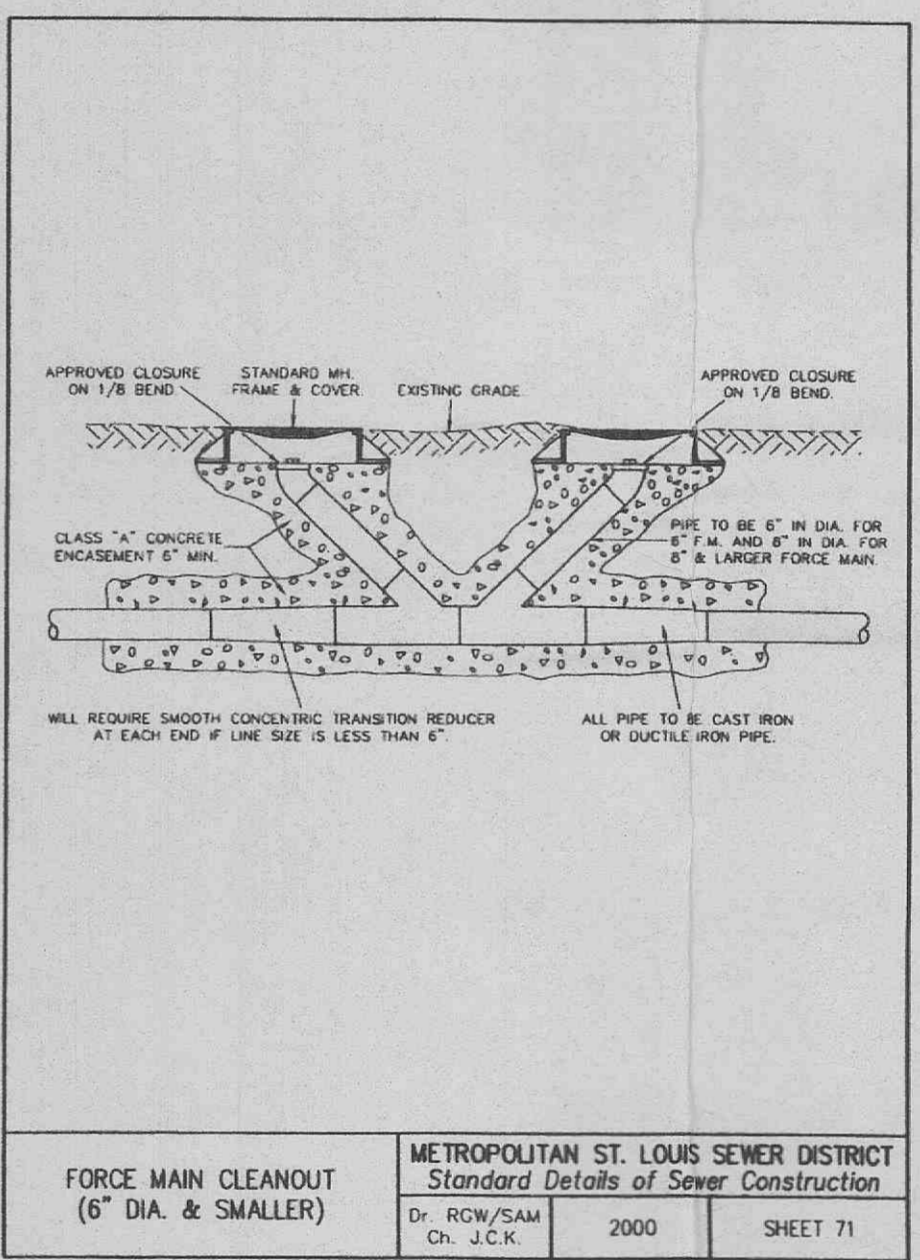

FORCE MAIN CLEANOUT (6" DIA. & SMALLER)
 METROPOLITAN ST. LOUIS SEWER DISTRICT
 Standard Details of Sewer Construction
 Dr. ROW/SAM Ch. J.C.K. 2000 SHEET 71

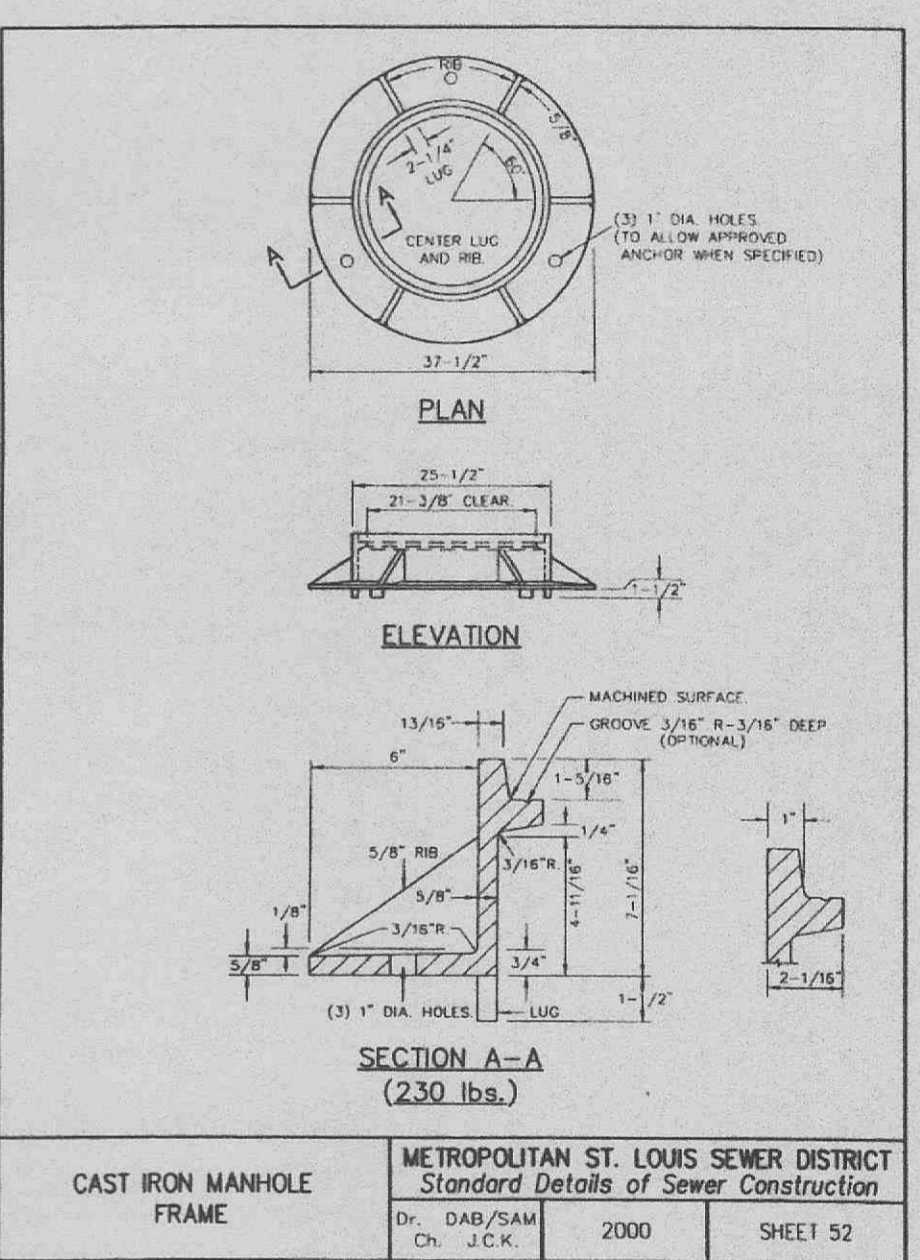

CAST IRON MANHOLE FRAME
 METROPOLITAN ST. LOUIS SEWER DISTRICT
 Standard Details of Sewer Construction
 Dr. DAB/SAM Ch. J.C.K. 2000 SHEET 52

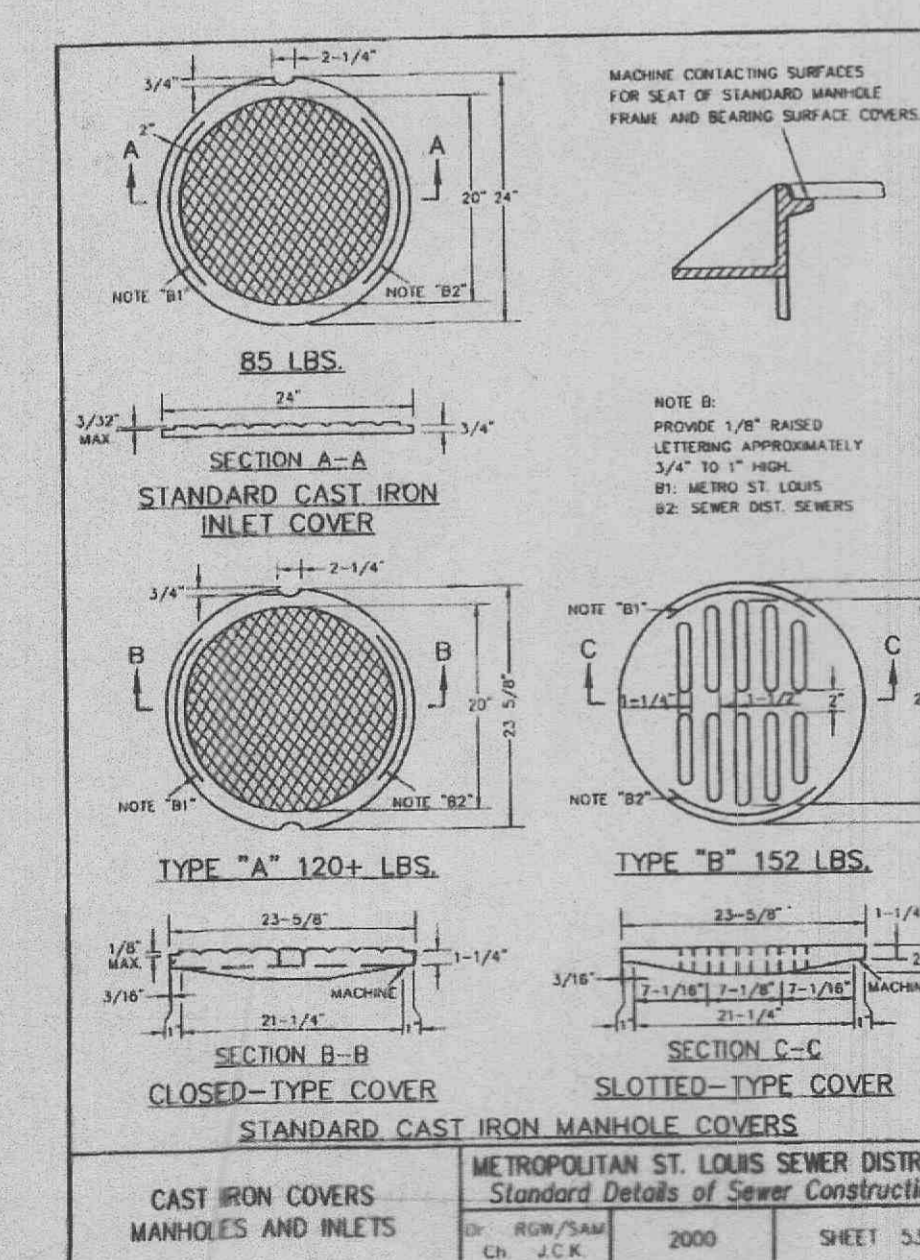

CAST IRON COVERS MANHOLES AND INLETS
 METROPOLITAN ST. LOUIS SEWER DISTRICT
 Standard Details of Sewer Construction
 Dr. ROW/SAM Ch. J.C.K. 2000 SHEET 53

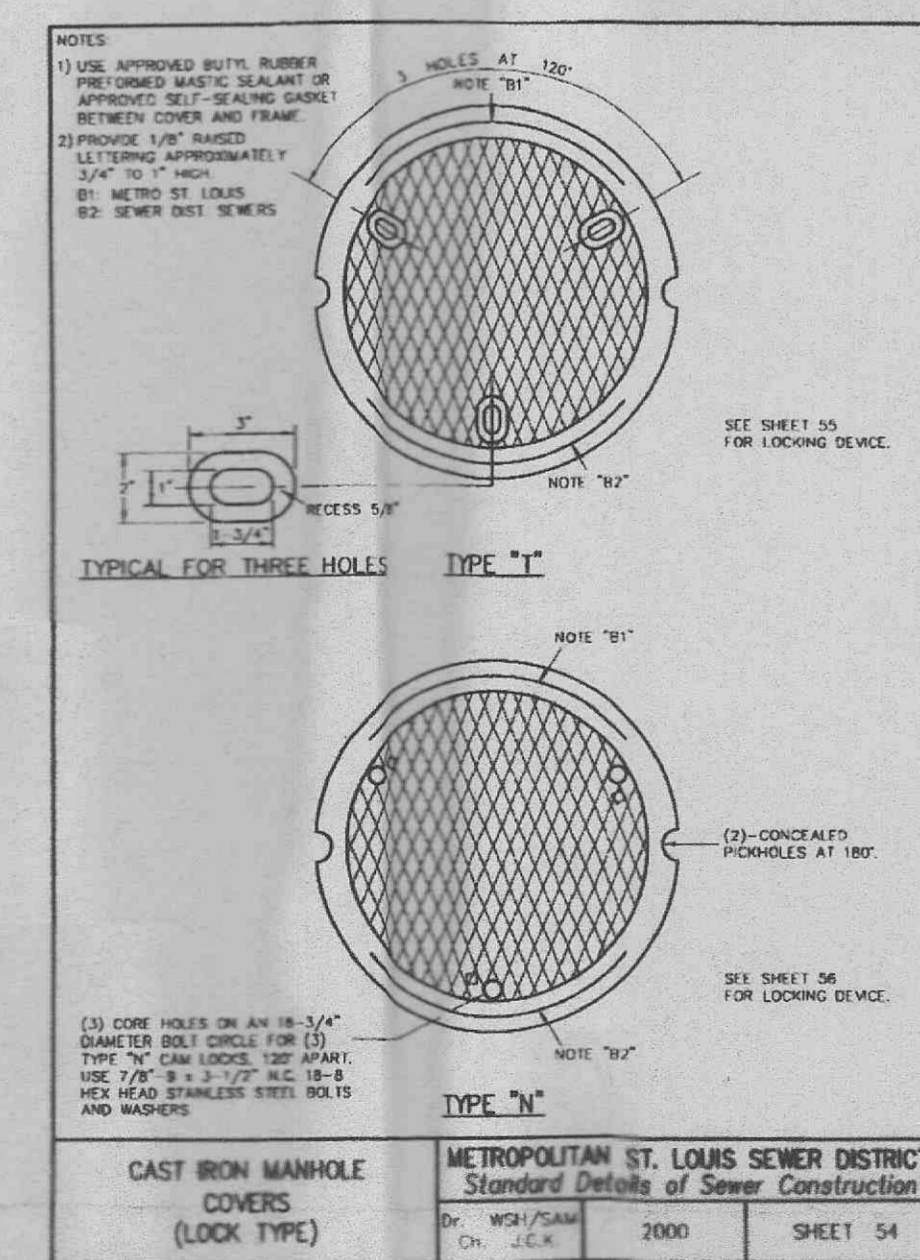

CAST IRON MANHOLE COVERS (LOCK TYPE)
 METROPOLITAN ST. LOUIS SEWER DISTRICT
 Standard Details of Sewer Construction
 Dr. WSH/SAM Ch. J.C.K. 2000 SHEET 54

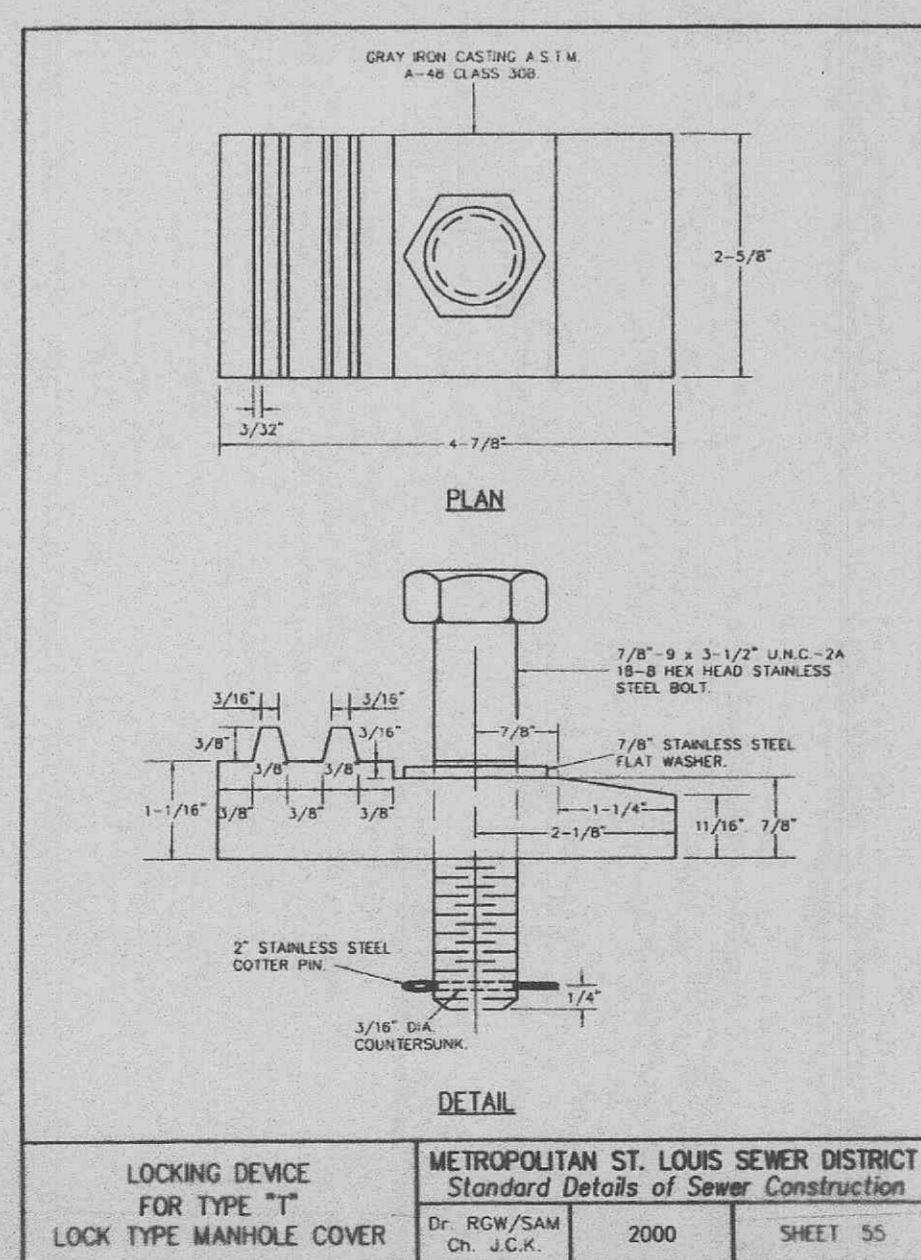

LOCKING DEVICE FOR TYPE "T" LOCK TYPE MANHOLE COVER
 METROPOLITAN ST. LOUIS SEWER DISTRICT
 Standard Details of Sewer Construction
 Dr. ROW/SAM Ch. J.C.K. 2000 SHEET 55

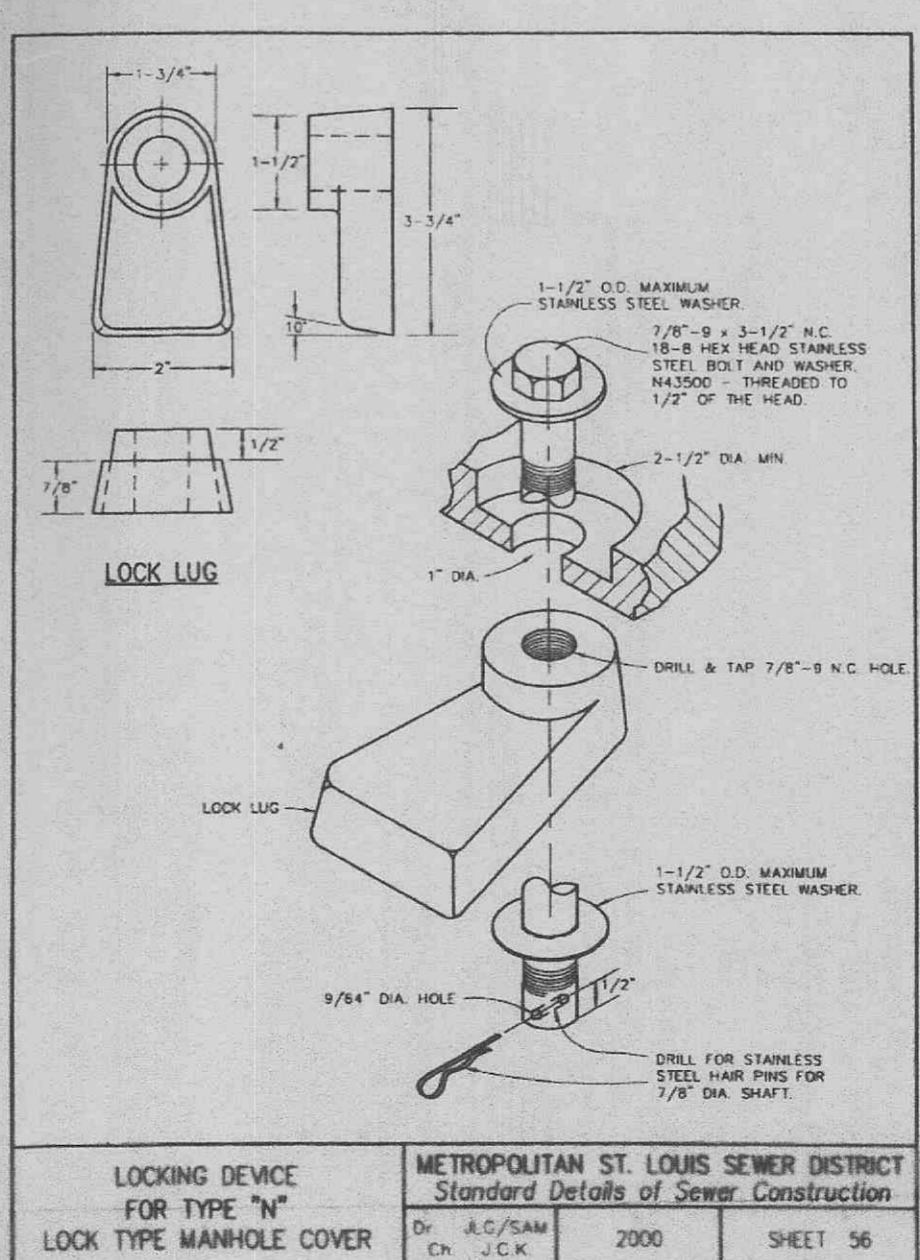

LOCKING DEVICE FOR TYPE "N" LOCK TYPE MANHOLE COVER
 METROPOLITAN ST. LOUIS SEWER DISTRICT
 Standard Details of Sewer Construction
 Dr. A.C./SAM Ch. J.C.K. 2000 SHEET 56

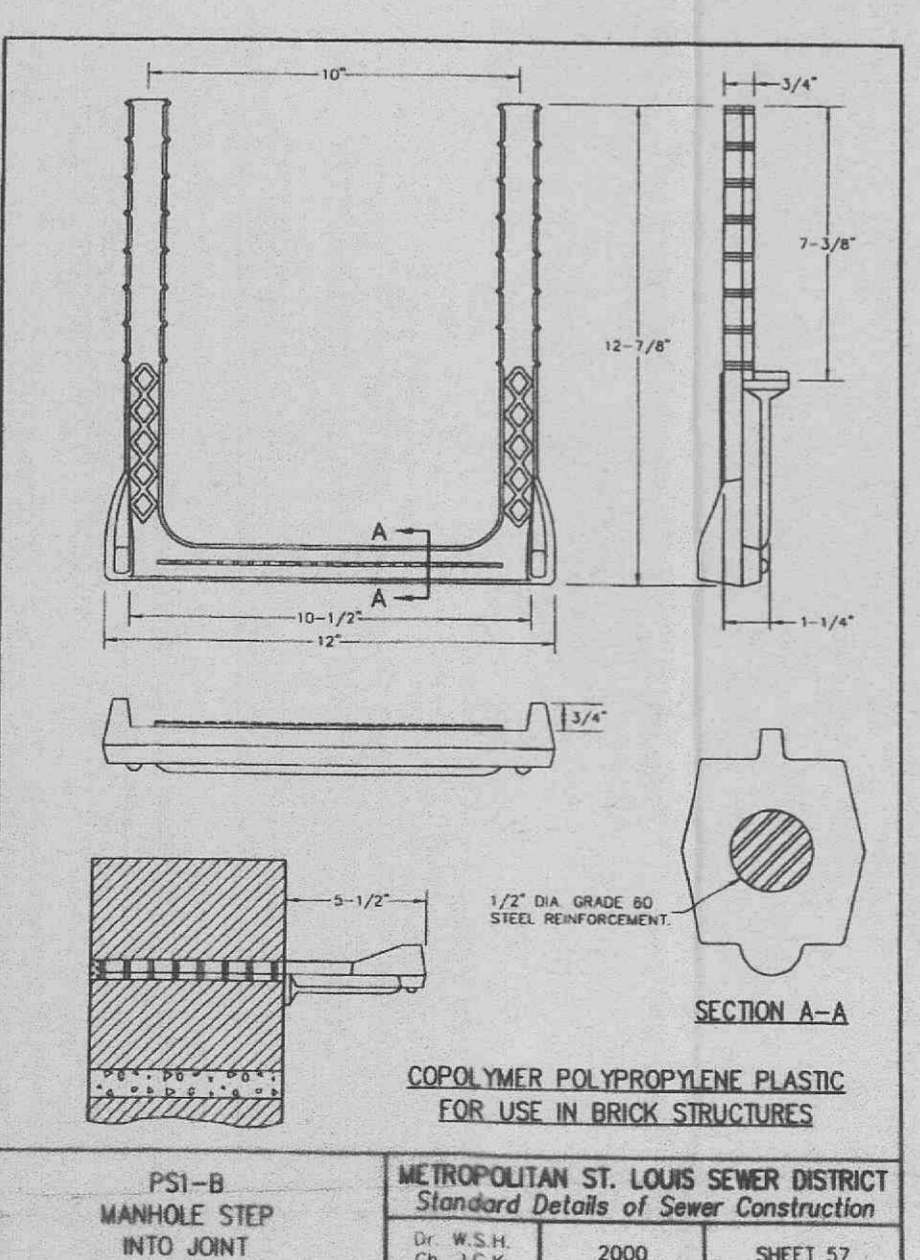

PSI-B MANHOLE STEP INTO JOINT
 METROPOLITAN ST. LOUIS SEWER DISTRICT
 Standard Details of Sewer Construction
 Dr. WSH Ch. J.C.K. 2000 SHEET 57

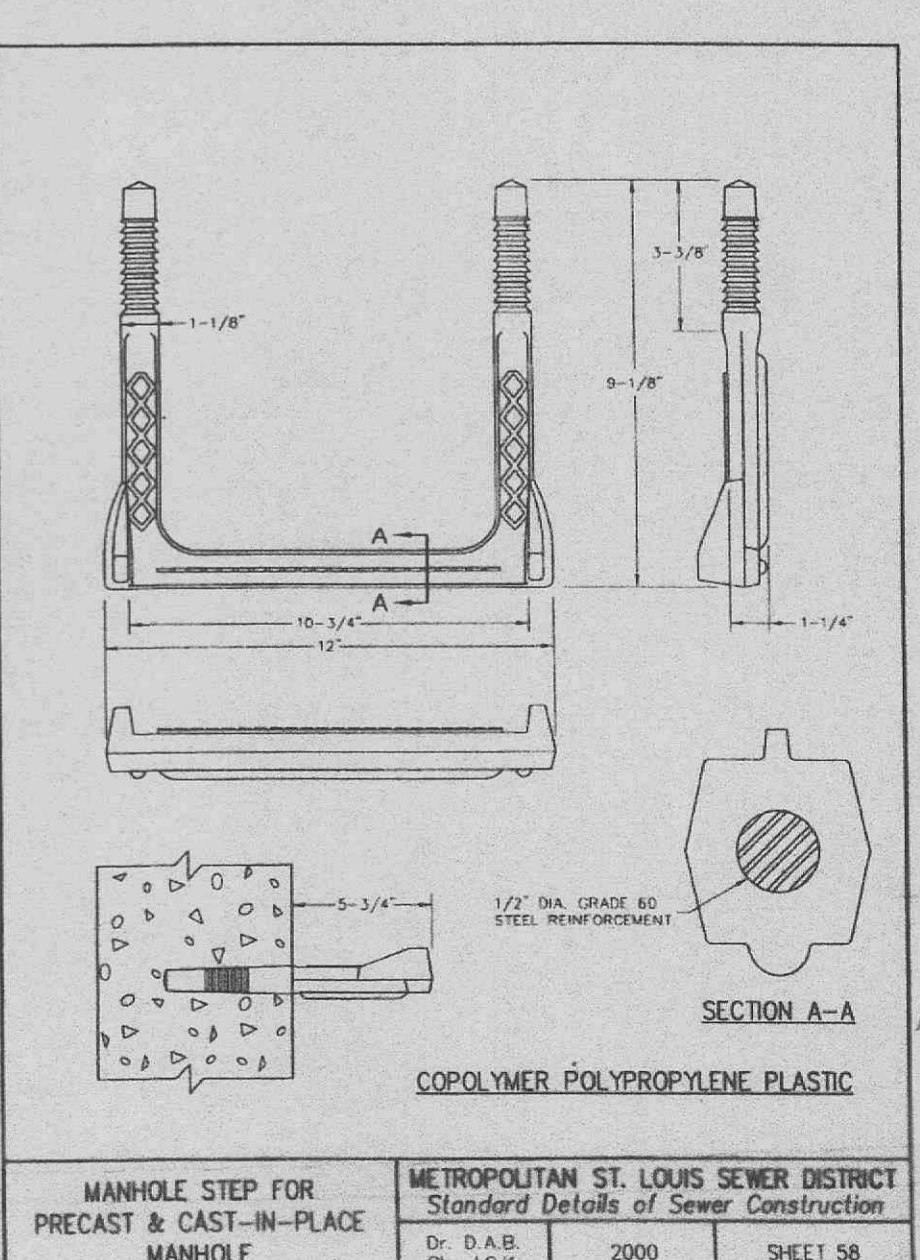

MANHOLE STEP FOR PRECAST & CAST-IN-PLACE MANHOLE
 METROPOLITAN ST. LOUIS SEWER DISTRICT
 Standard Details of Sewer Construction
 Dr. DAB Ch. J.C.K. 2000 SHEET 58

PUND PLACE
 SANITARY DETAILS

ST. CHARLES ENGINEERING & SURVEYING, INC.
 801 S. FIFTH STREET, SUITE 202
 ST. CHARLES, MO 63801
 TEL: (636) 947-0007 FAX: (636) 947-2448



ORDER NO.

DATE
 8-28-01

C-14