

STORM SEWER NOTES:

TO ADDRESS PHASE II STORM WATER GUIDELINES, INLETS 1-4 AND 1-5 WILL HAVE A CATCH BASIN INSERT INSTALLED. CATCH BASIN INSERT TO BE A TRITON™ MODEL TR1818 BY CONTECH. SEE SHEET 7 FOR MAINTENANCE DETAILS.

MAINTENANCE NOTE:
THE OWNER SHALL COMPLY WITH THE "STORMWATER MANAGEMENT AND BEST MANAGEMENT PRACTICES FACILITIES MAINTENANCE AGREEMENT" PER ORDINANCE #5271, CITY CODE 405.247.

GRADING AND DRAINAGE LEGEND

ST	STORM PIPE (<10" NEW)
ST	STORM PIPE (>12" NEW)
ST	STORM PIPE (>12" EXISTING)
---	MAJOR CONTOUR (NEW)
---	MINOR CONTOUR (NEW)
---	MAJOR CONTOUR (EXISTING)
---	MINOR CONTOUR (EXISTING)
TC=485.50 G=485.00	TOP CURB/GUTTER (NEW)
---	FINISHED GRADE (NEW)
TC=485.50 G=485.00	SPOT ELEVATION (EXISTING)
2%	SLOPE PERCENTAGE (RISE/RUN)
4:1	SLOPE RATIO (RUN:RISE)
---	CRUSHED STONE SUB-BASE IN LIEU OF STANDARD # 57 STONE

MH 1-1	TOP=484.55 FLin=478.67 FLout=478.05+/-
MH 1-2	TOP=485.70 FLin=479.60 FLout=479.40
GI 1-3	GRATE=483.80 FLin=480.30 FLout=480.10
GI 1-4	GRATE=485.10 FL=481.60

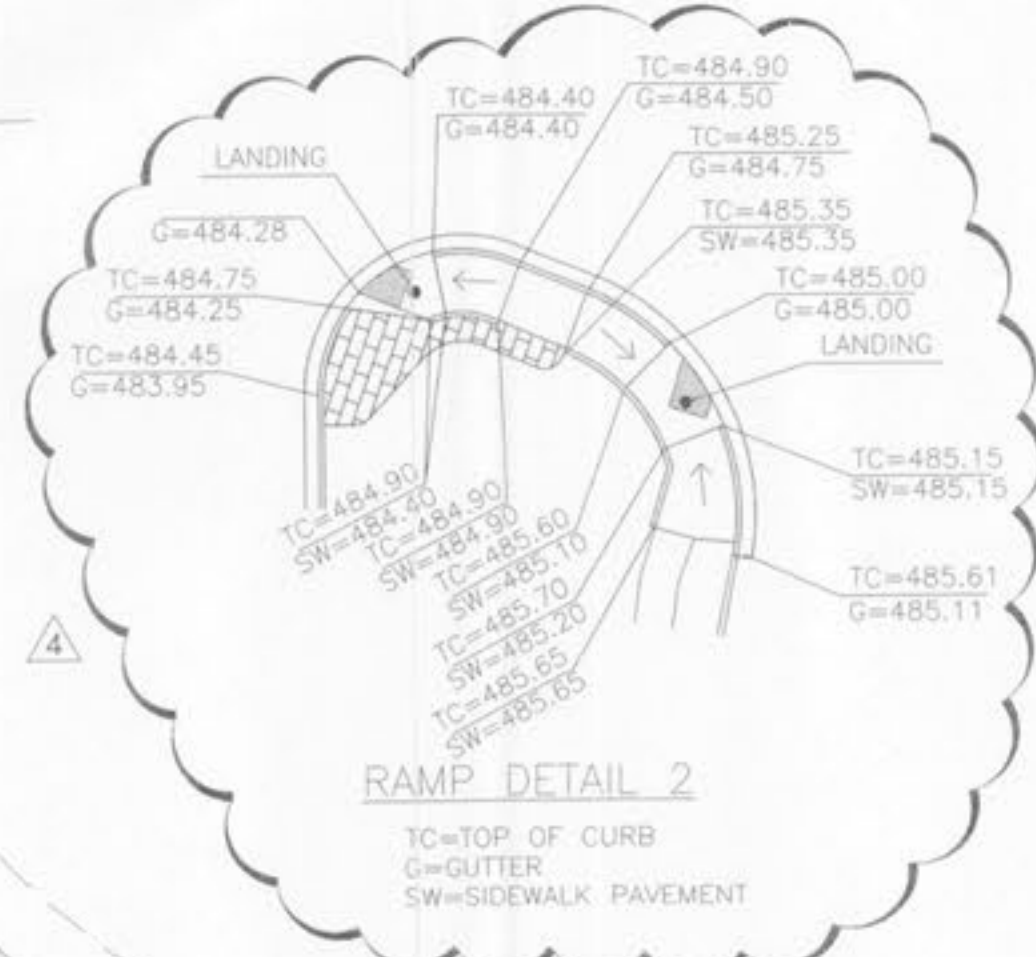
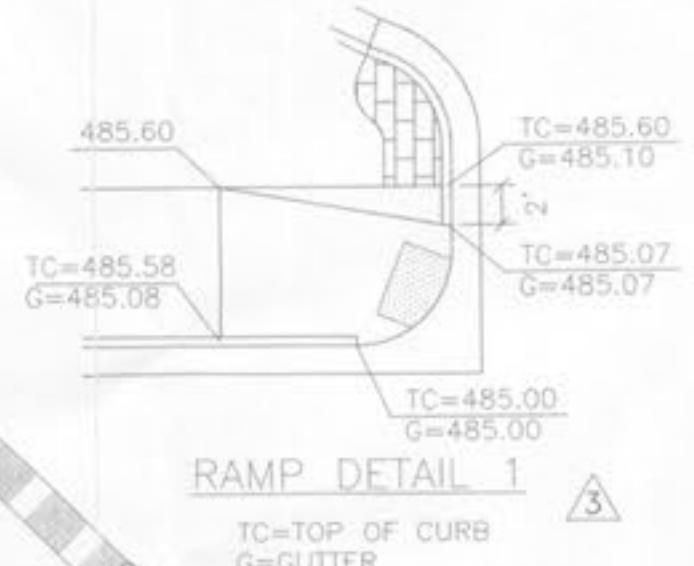

GENERAL NOTES

- GAS CANOPY INSTALLER SHALL INSTALL THE CANOPY COLUMN DRAIN PIPE AND OVERFLOW FITTING. THE STORM WATER INSTALLER SHALL CONNECT THEIR PIPING TO THE GAS INSTALLER'S OVERFLOW FITTING.
- TO AVOID ANY DEFINED CRESTS OR SUMPS, "GRADE BREAKS" SHALL BE CONSTRUCTED AS A "VERTICAL CURVE" SURVEYOR & CONTRACTOR SHALL CONFER WITH QUIKTRIP CONSTRUCTION MANAGER PRIOR TO CONSTRUCTION STAKING OR CONCRETE PLACEMENT RELATIVE TO ANY GRADE BREAKS.
- NO SLOPES SHALL BE STEEPER THAN 3 (HORIZONTAL) TO 1 (VERTICAL).

No.	Revision	Date
3	CITY COMMENTS	04/22 2010
3	CITY COMMENTS	03/29 2010
2	CITY COMMENTS/BID SET	03/05 2010
1	CITY COMMENTS	02/08 2010

EFK • Moen, LLC
Civil Engineering Design
13523 Barrett Parkway Dr. Suite 250
St. Louis, MO 63021
Phone (314)729-4100 Fax (314)729-4199

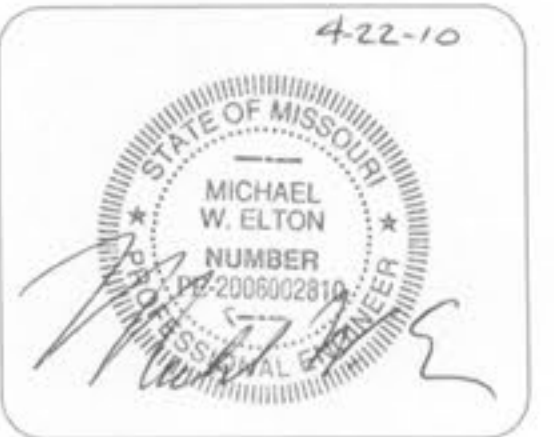

GRADING PLAN

DRAWN BY: MWE	SHEET 4 OF 13
DESIGNED BY: MWE	
CHECKED BY: PJK	
ISSUE DATE: 12/14/2009	



Z:\QuikTrip\08071_01640_0\Fallon, Mo\DWG\0640_Base.dwg - Grading Apr 22, 2010 - 12:16pm - mweilton

801 BELLEAU CREEK ROAD OFALLON, MO QuikTrip Store No. : 640RE