

PROJECT NO.: 141029
 NAME: MICHAEL J. VELLOFF
 LICENSE NUMBER: E-2000161862
 DISCIPLINE: CIVIL
 CORPORATION AUTHORITY NUMBER: 001194

THE SEAL OF MICHAEL J. VELLOFF ON THIS DRAWING APPLIES ONLY TO THE CIVIL/SITE ENGINEERING WORK SHOWN. IT DOES NOT APPLY, NOR IS ANY RESPONSIBILITY TAKEN FOR ENVIRONMENTAL, GEOTECHNICAL (INCLUDING BUT NOT LIMITED TO SLOPE STABILITY), STRUCTURAL, HVAC, PLUMBING, ELECTRICAL, FIRE PROTECTION, TRAFFIC ENGINEERING, SURVEYING (BOUNDARY AND TOPOGRAPHIC), OR ARCHITECTURAL (BUILDING OR LANDSCAPE).

QuikTrip No. 0643S
 8601 Mexico Road
 O'Fallon, Missouri 63366



REDI-ROCK® 41" SERIES BLOCKS ARE AN UNPATENTED USE, REPRODUCTION, PUBLICATION, DISTRIBUTION, OR SALE IN WHOLE OR IN PART, IS STRICTLY FORBIDDEN.

PROTOTYPE: P-83
 DIVISION: 06
 VERSION: 001
 DESIGNED BY: RKF
 DRAWN BY: RKF
 REVIEWED BY: MJV

REV	DATE	DESCRIPTION
1	12-21-15	CONSTRUCTION SET

ORIGINAL ISSUE DATE: 07-24-15

SHEET TITLE:
 RETAINING WALL PROFILES

SHEET NUMBER:
C302

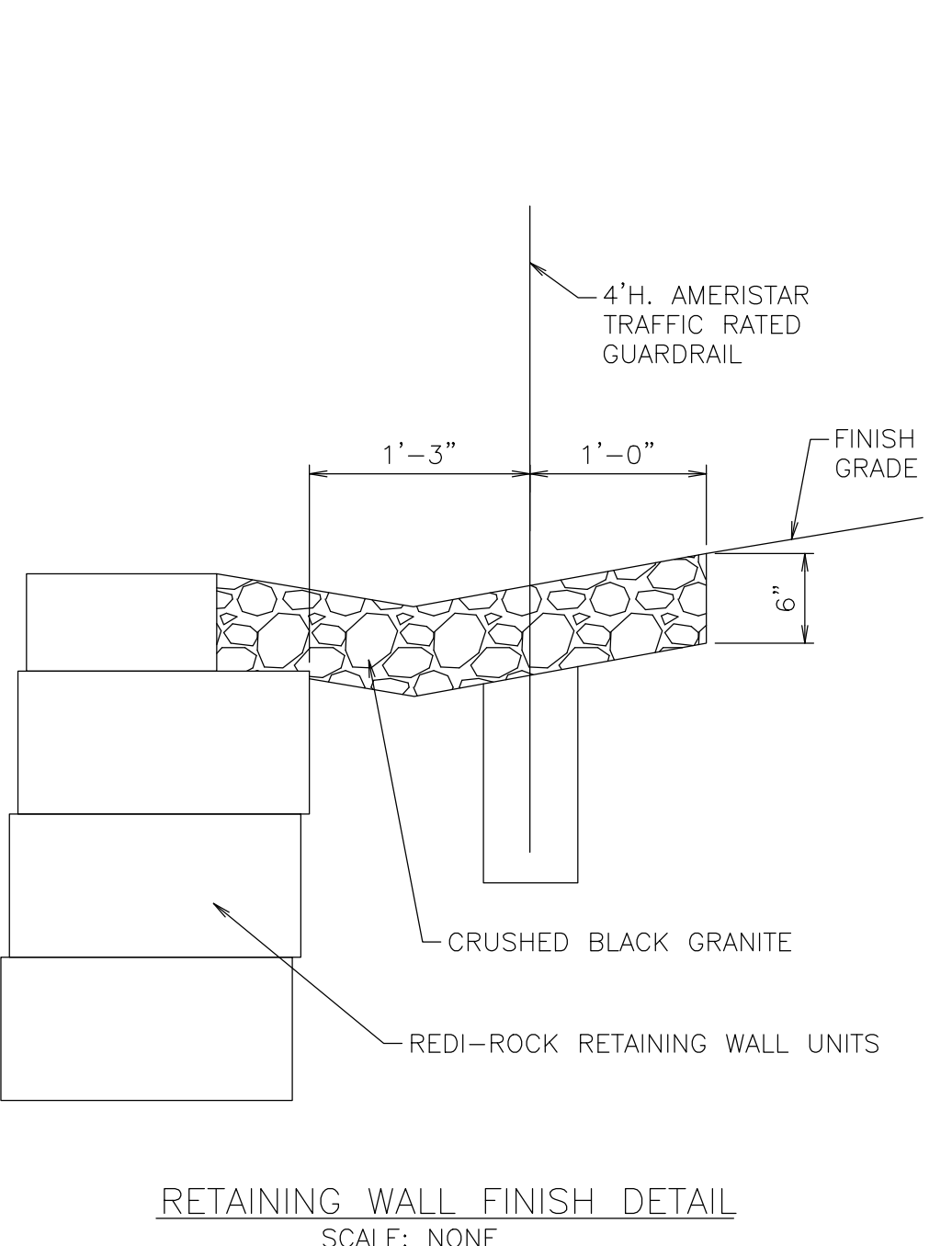
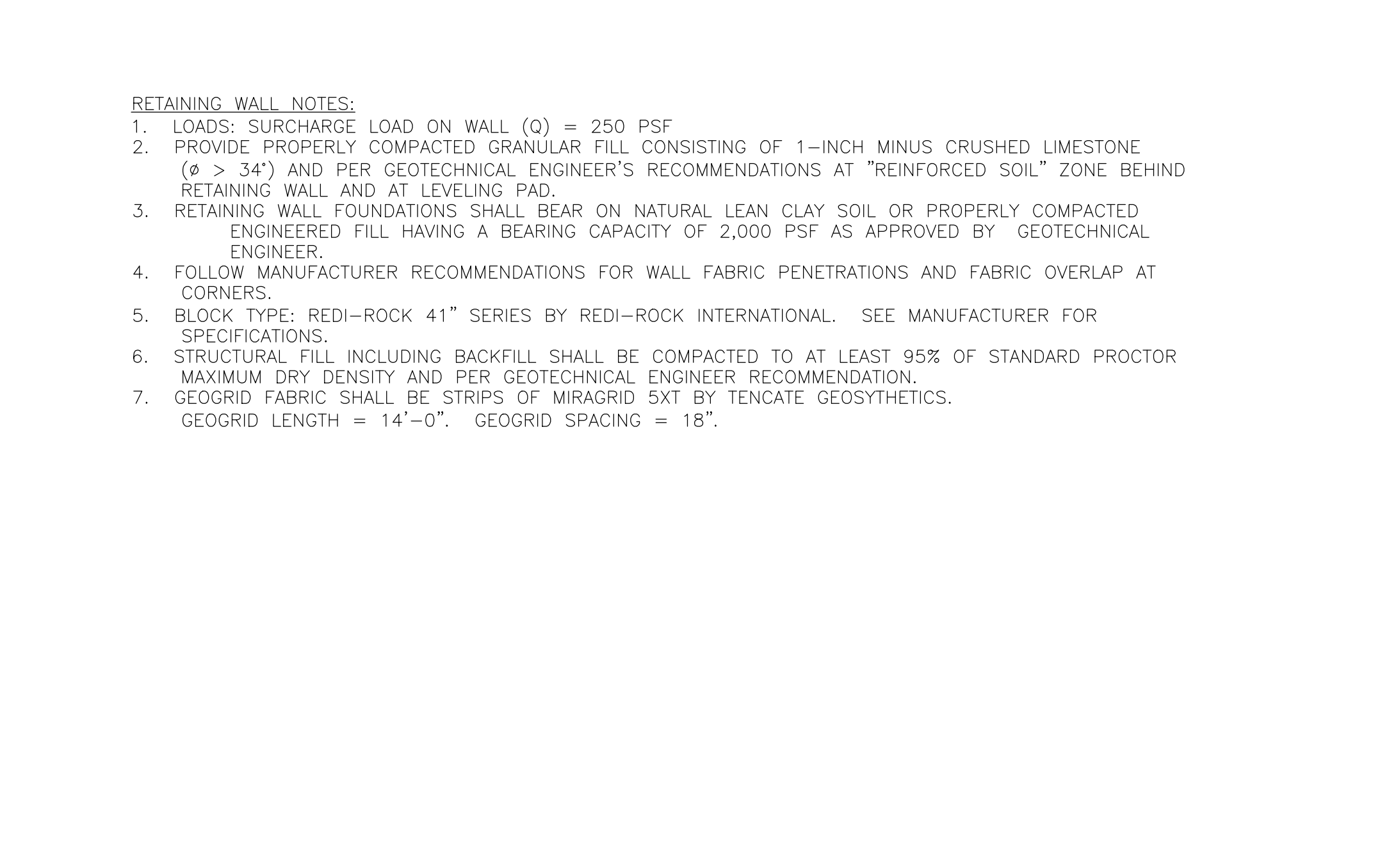
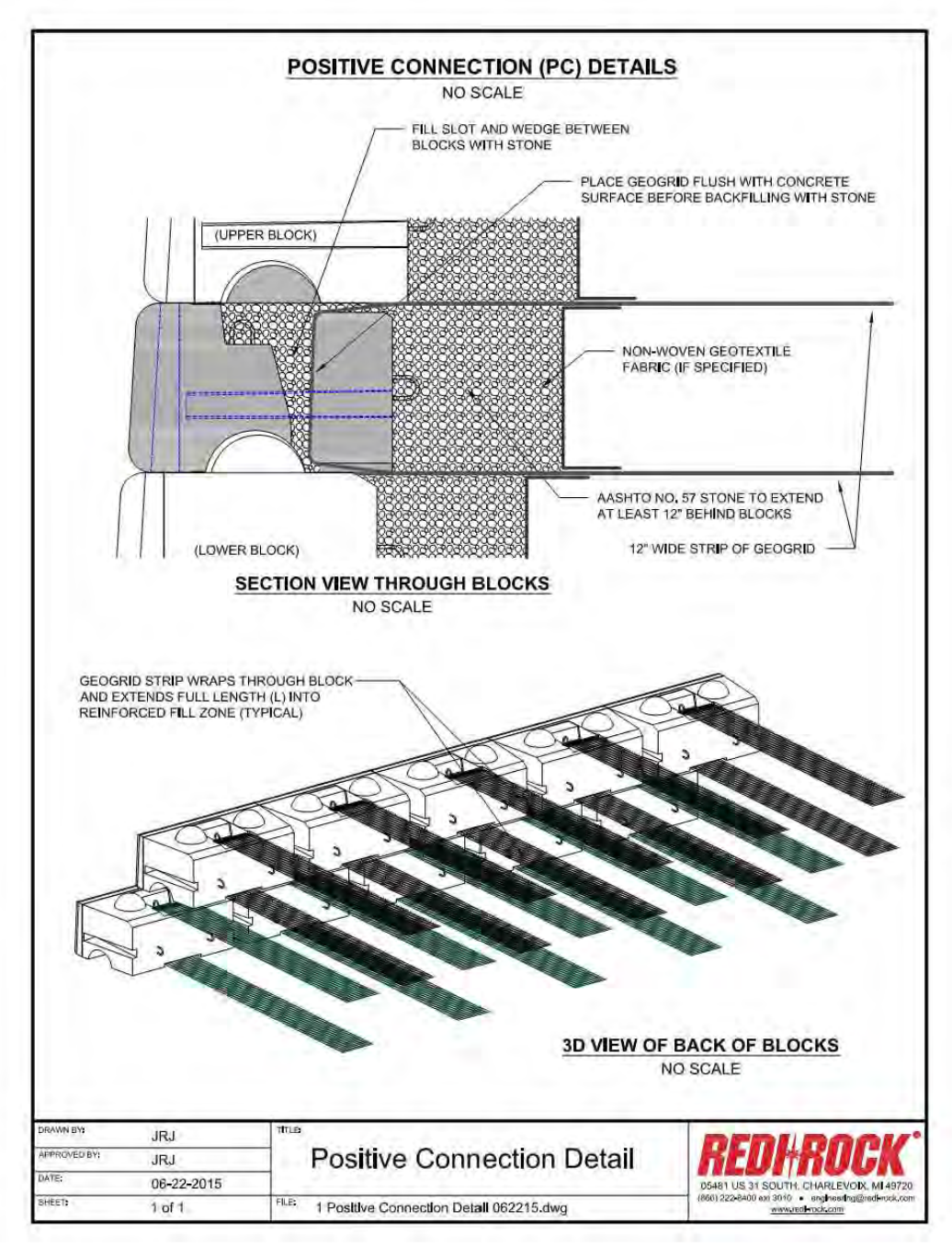
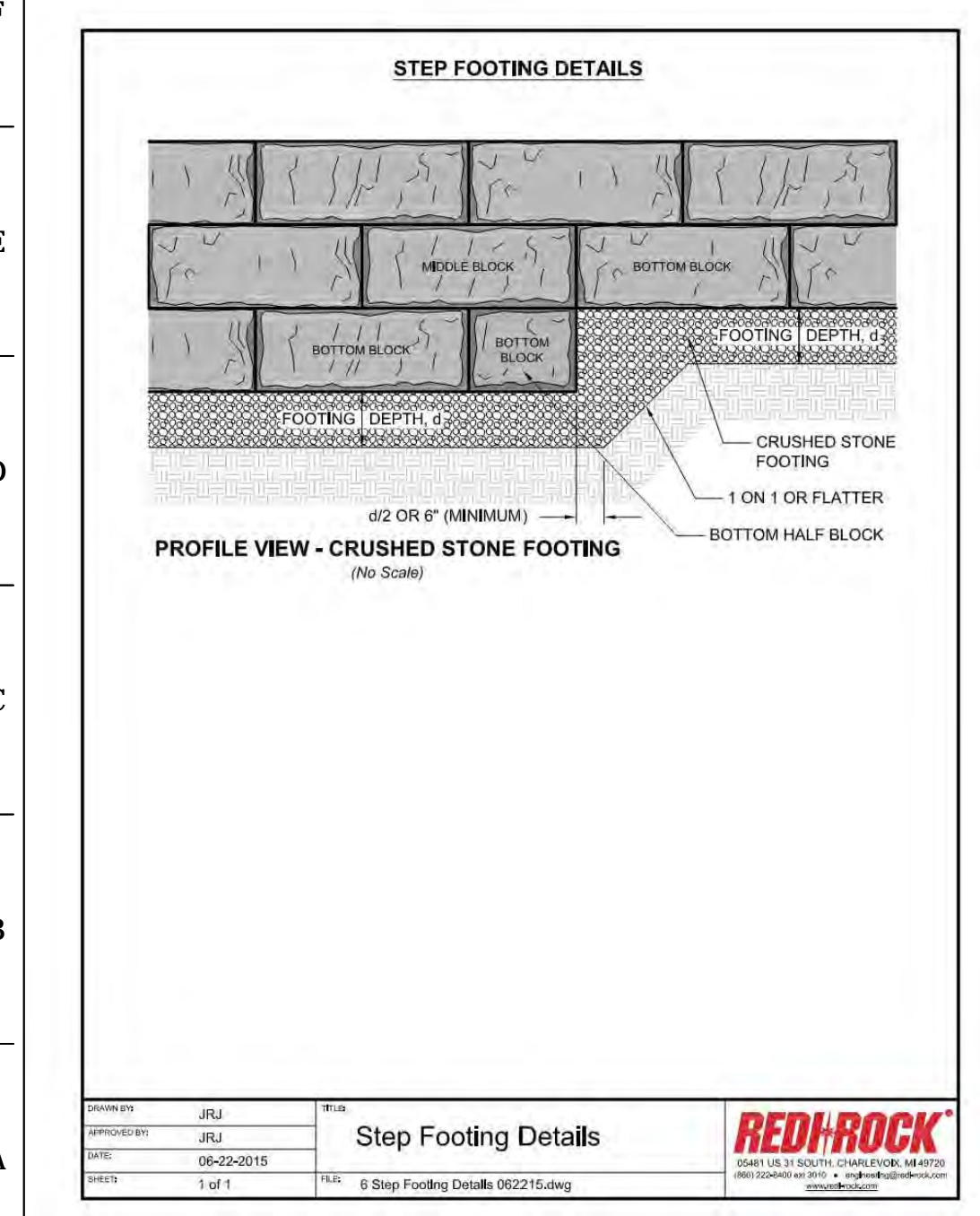
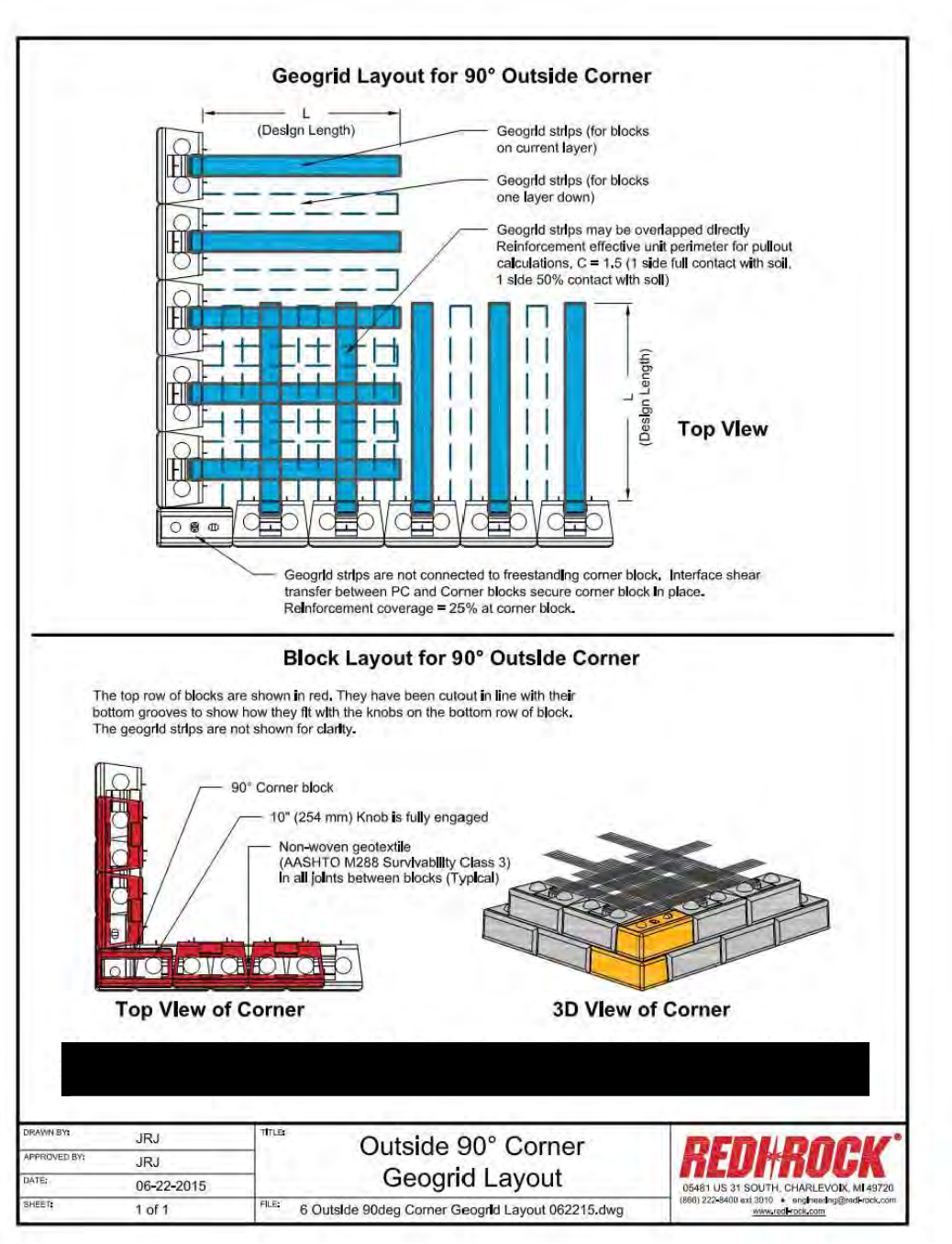
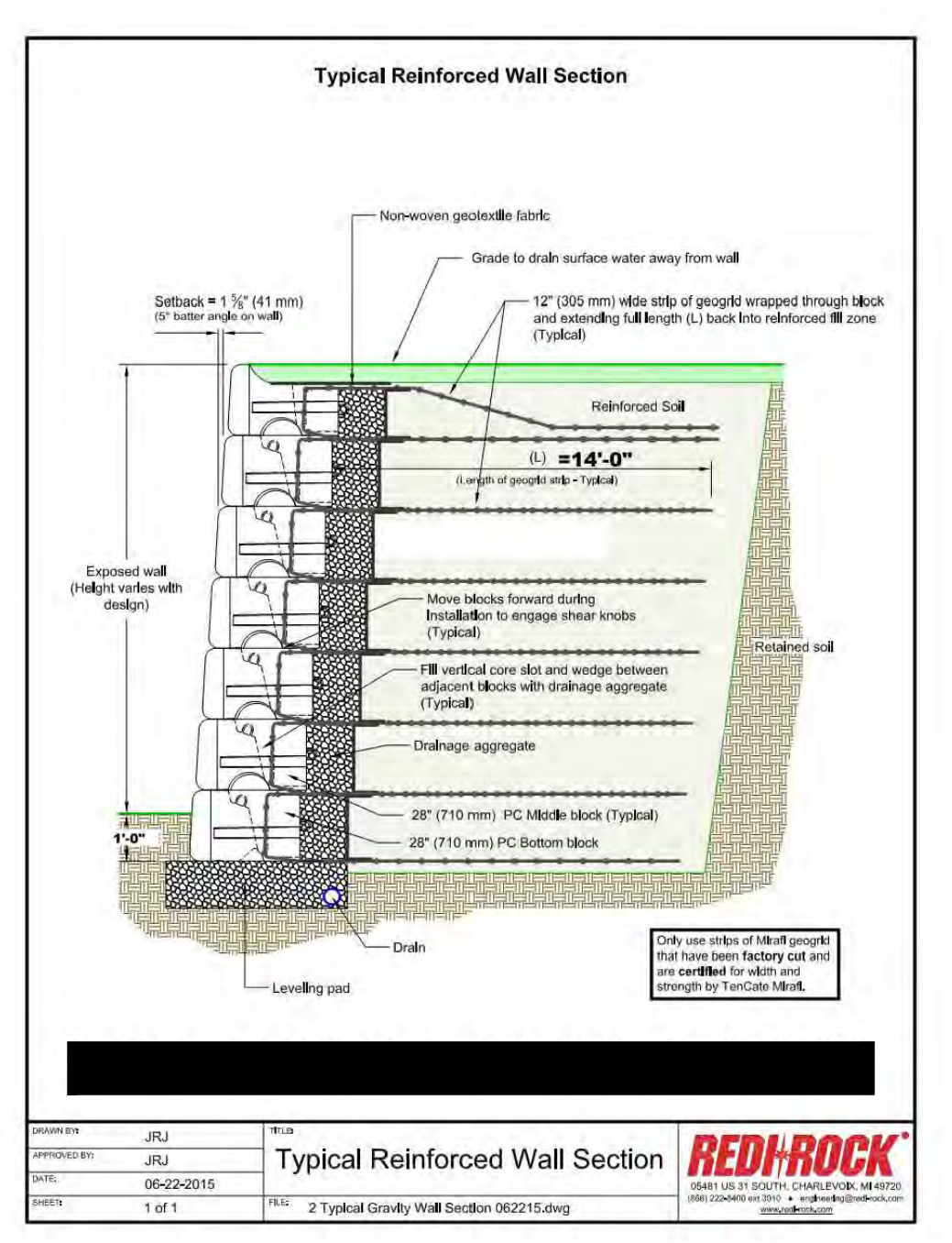
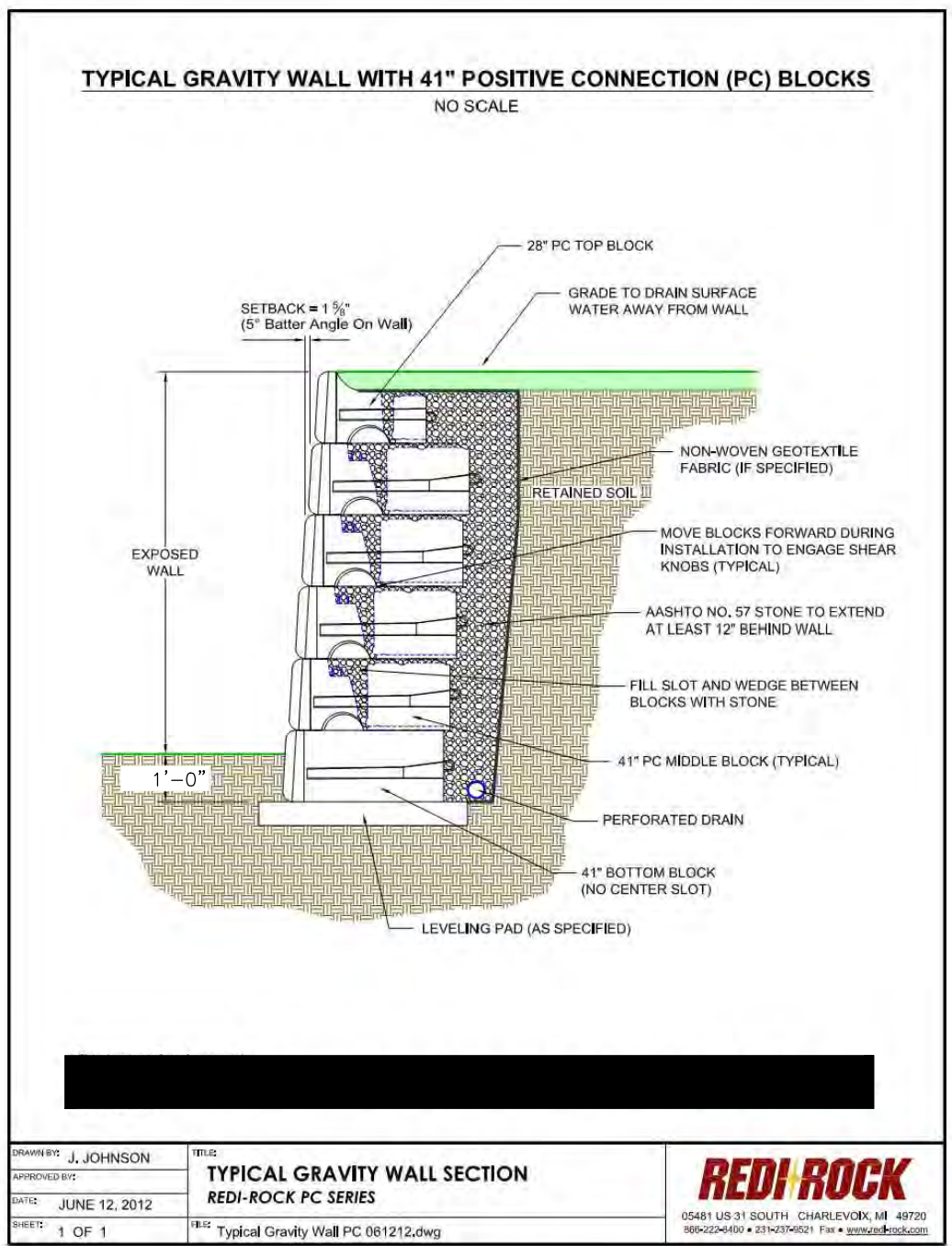
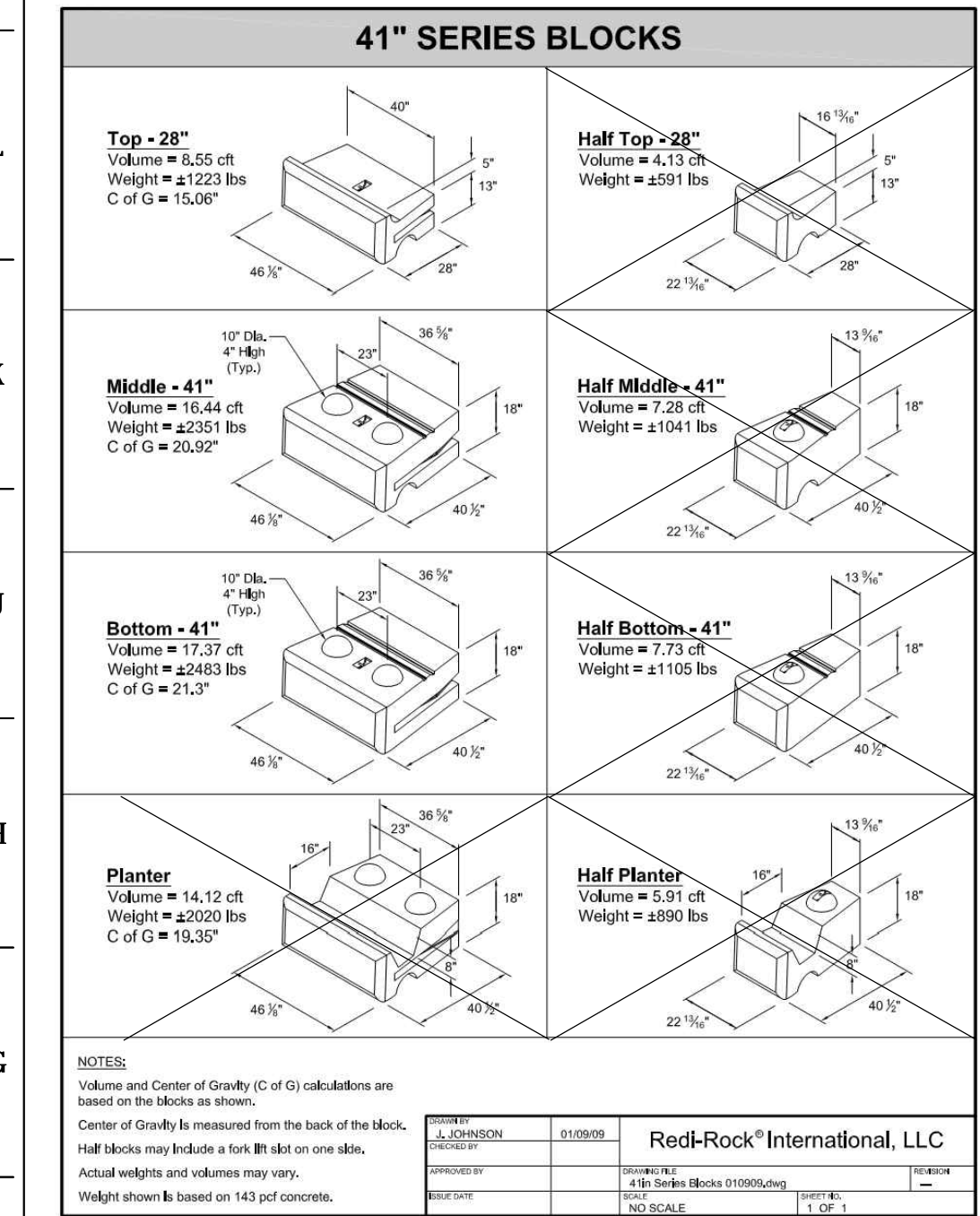
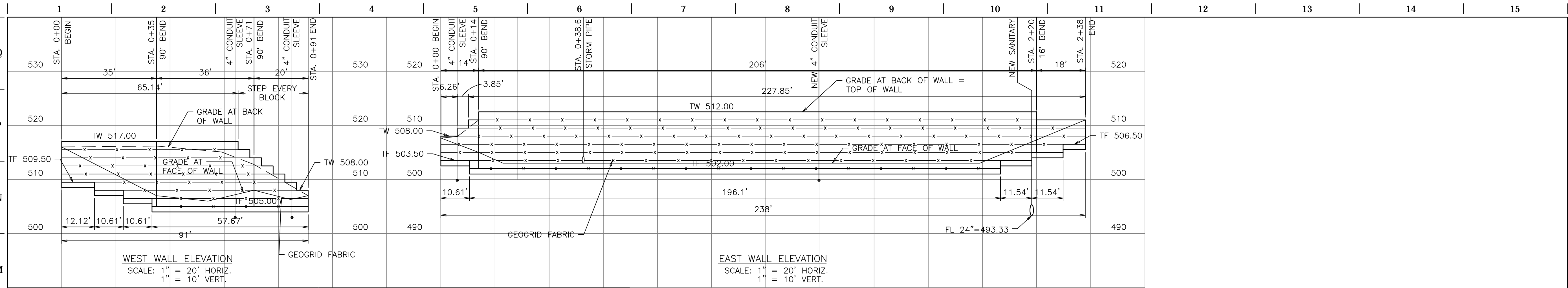

FILE LOCATION: \\141029 - QuikTrip #0643 Mexico and Highway K (Civil) - 0643 C302.dwg USER: rkyer SAVED: 12/15/2015 2:57 PM PLOTTED: 12/16/2015 8:23 AM