

**GENERAL NOTES**

- Underground facilities, structures and utilities have been plotted from available surveys, records and information, and, therefore, do not necessarily reflect the actual existence, non-existence, size, depth, type, number or location of these facilities, structures and utilities. The Contractor shall be responsible for verifying the actual location of all underground facilities, structures and utilities, either shown or not shown on these plans in the field prior to any grading, excavation or construction of improvements. These provisions shall in no way absolve any party from complying with the Underground Facility Safety and Damage Prevention Act, Chapter 319, RSMo. Contractor to contact MODOU Traffic Division to locate existing signal & lighting & underground wires or cable prior to construction.
- Contractor to verify location and flowline of existing sewers and water line prior to connection. All connections to be made in accordance with local codes and/or utility companies requirements.
- All site preparation, grading or fill for construction of footings, slabs and parking areas to be in accordance with the requirements outlined in the Investigation of Subsurface Conditions and Foundation recommendations.
- Face of all inlets to be set 2 feet behind back of curb unless otherwise shown on the plans. Top of inlets shall be set flush with top of curb where 6" vertical curbs are installed.
- All concrete pipe shall be reinforced concrete pipe and meet current A.S.T.M. Specification C-76 and shall be Class II unless otherwise noted. All other concrete pipe shall meet current A.S.T.M. Specification C-14 and shall be standard strength unless otherwise noted on profiles. All on-site storm sewer pipe shall be PVC SDR-35 unless otherwise noted, conforming to ASTM D3404, with joints conforming to ASTM D3212 unless otherwise noted on the plans.
- Joints for concrete pipe shall be rubber gasketed meeting ASTM C-443 with a main sealing surface of no less than 3 inches.
- All fill under storm or sanitary lines constructed above original grade shall be compacted to 95% of maximum dry density as determined by the modified AASHTO Compaction Test T180 (Current A.S.T.M. Specification D-698), and verified by a Soils Engineer prior to installing pipe.
- Location and elevation of field inlets, manholes and culvert pipes to be verified by Engineer after stakeout and prior to construction.
- All materials and methods of construction for sewers to meet the current requirements of the City of O'FALLON.
- All sewer structures to conform to the City of O'FALLON standard details.
- All trenches under or adjacent to the proposed corrugated metal detention storage pipe (CMP) shall be backfilled to subgrade elevation with compacted 1" minus crushed limestone.
- All materials and fabrication shall be in accordance with AASHTO Specification M-36. All installation shall be in accordance with the manufacturer's specifications.
- The Collector Piping shall be fabricated from #16 gauge Polymer Coated Steel Coils meeting the requirements of AASHTO Specification M-246. All materials and fabrication shall be in accordance with AASHTO Specification M-36. (All pipe shall be helically corrugated). Each pipe end shall have at least two annular corrugations to accept Strip Gasket and a connecting band. Connecting bands shall have two corrugations that engage the annular corrugations on the ends of the pipe. Bands shall be joined by band angle and strap connectors (for approved equal). All installation shall be in accordance with the Manufacturer's recommendations. Contractor shall provide shop drawings of CMP fabrication to city for approval.
- All trenches under, or adjacent to proposed pavement shall be backfilled to subgrade elevation with compacted 3/4" minus crushed limestone. Crushed limestone shall be compacted to 95% density as determined by the Standard Proctor Test AASHTO T-99 (ASTM D-698). All other trenches within the road right-of-way shall be backfilled with suitable earth embankment material free from rubbish and debris and lumps, clods or rocks larger than 2 inches placed in 6" layers and compacted to the same density as above. Trenches not in road right-of-way or under or adjacent to pavement may be backfilled with earth embankment material defined above, jetted and neatly rounded to allow for subsequent settlement, unless otherwise directed by the Engineer.
- On site pavement shall consist of 8 inches of 4000 PSI concrete with #4 rebar 48" on center each way but not continuing through construction joints. Pavement over underground tanks shall be 8" thick concrete with #4 rebar 48" on center each way for a distance of 5' past tank hole excavation. Construction joints shall be placed every 20' parallel to store front with smooth greased dowels 48" on center and control joints every 20' perpendicular to store front with smooth greased dowels 48" on center. Rebar shall not continue through joints. Eliminate all keyways. Expansion joints to be provided along curb and gutter. Construction joints not to exceed 20' on center with saw joints maximum of 20' on center.
- The contractor moving earth on the site shall be responsible for the erection and maintenance of siltation barriers or basins to protect off-site streets and downstream properties from damage due to soil erosion. Additions or changes to such devices shall be made in accordance with the requirements of the City Engineer.
- No slope shall be greater than 2:1 and all areas disturbed by grading shall be protected by seeding and mulching or paving as soon as possible. All disturbed off-site areas to be sodded within 30 days of initial disturbance.
- For refuse area details, refer to architectural drawings.
- Contractor to notify Engineer as soon as possible if conditions on ground differ from those shown on plans.
- All materials and methods of construction for the entrance onto BRYAN ROAD to meet the requirements of the city of O'FALLON. Concrete pavement shall be 8" concrete with #4 rebar at 48" each way on a 4" stone base with 6" vertical concrete curb. Concrete shall be six sack mix. Entire subgrade shall be shaped, compacted and rolled prior to placing base course. Local soft spots in subgrade encountered during pavement construction shall be undercut and replaced with a thicker rolled stone base section.
- Benchmark - SOUTHWEST CORNER OF FRONT FACE OF CURB INLET ON EAST SIDE OF RELOCATED BRYAN ROAD AT APPROXIMATE STATION 31+00. ELEVATION - 526.60 AS SHOWN ON SURVEY PREPARED BY GEORGE BUTLER ASSOCIATES INC., DATED AUGUST, 6 1997
- CONTROLLED FILL/EXCAVATION**
  - QuikTrip will employ the services of a Geotechnical Engineer to observe, test and approve all excavation, fill and backfill work and to determine that subgrade conditions are compatible with those used in the design.
  - All topsoil, organic material and existing structures shall be removed from the building area and from areas to be paved. Stockpile all topsoil for reuse.
- Controlled fill material:**
  - Granular fill: shall consist of washed, evenly graded mixture of crushed stone, or crushed or uncrushed gravel, with 100% passing a 1-1/2" sieve and not more than 5% passing a No. 4 sieve.
  - Controlled fill: shall consist of material having a relatively low plasticity with a liquid limit of less than 45% and a plasticity index of less than 21% or as recommended by the Geotechnical Engineer.
  - All material proposed for use as controlled fill shall be approved by the Geotechnical Engineer.

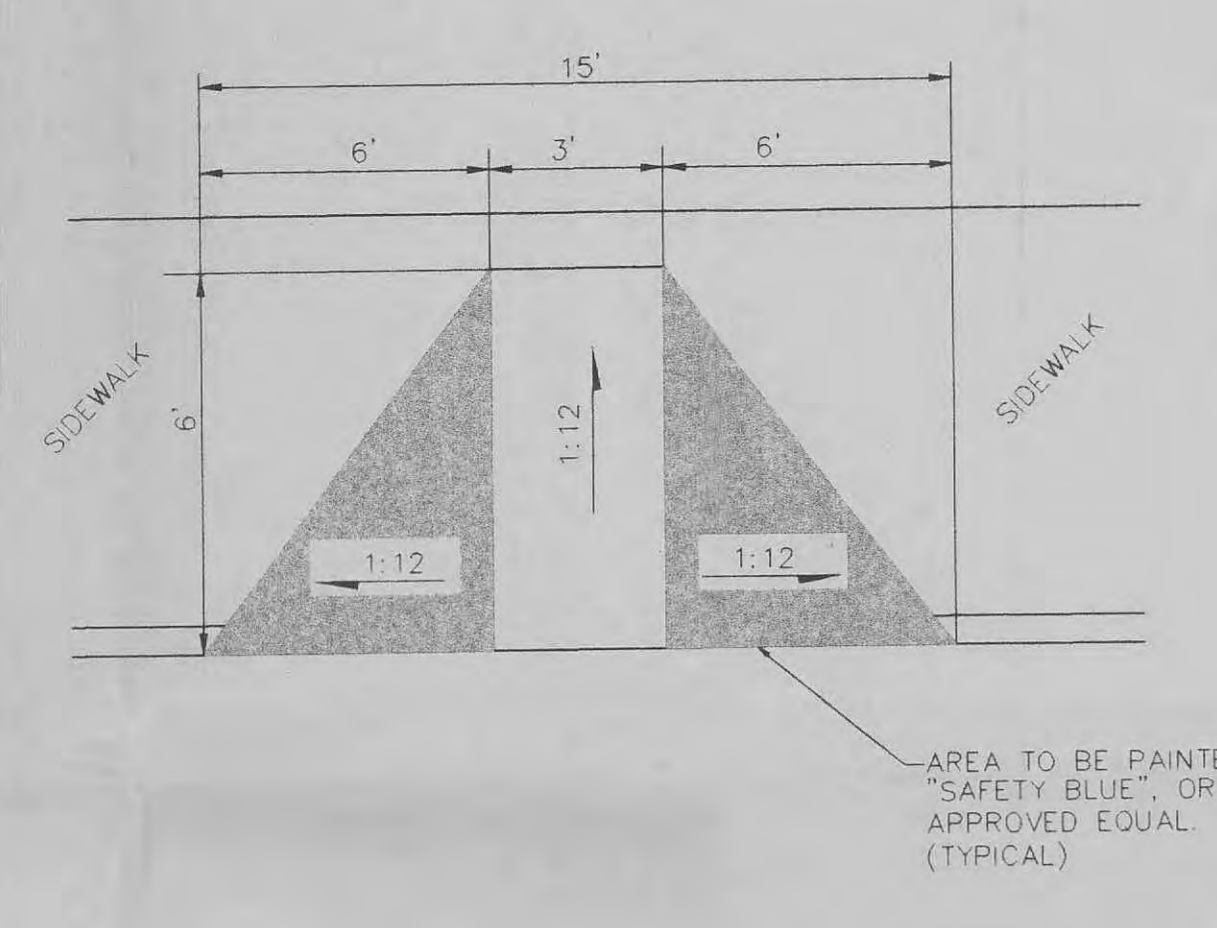

TYP. HANDICAP RAMP PLAN

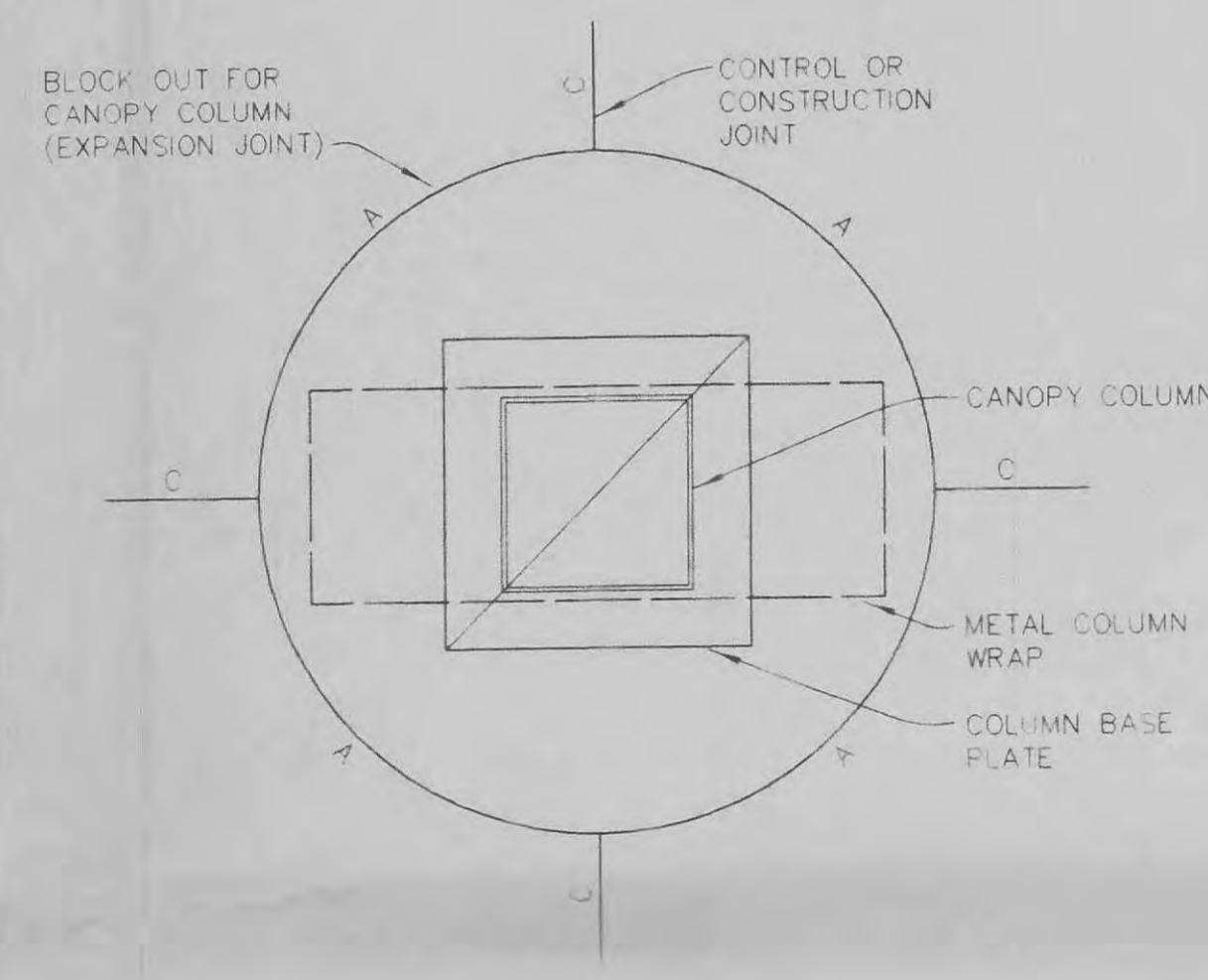

COLUMN BLOCKOUT PLAN DETAIL

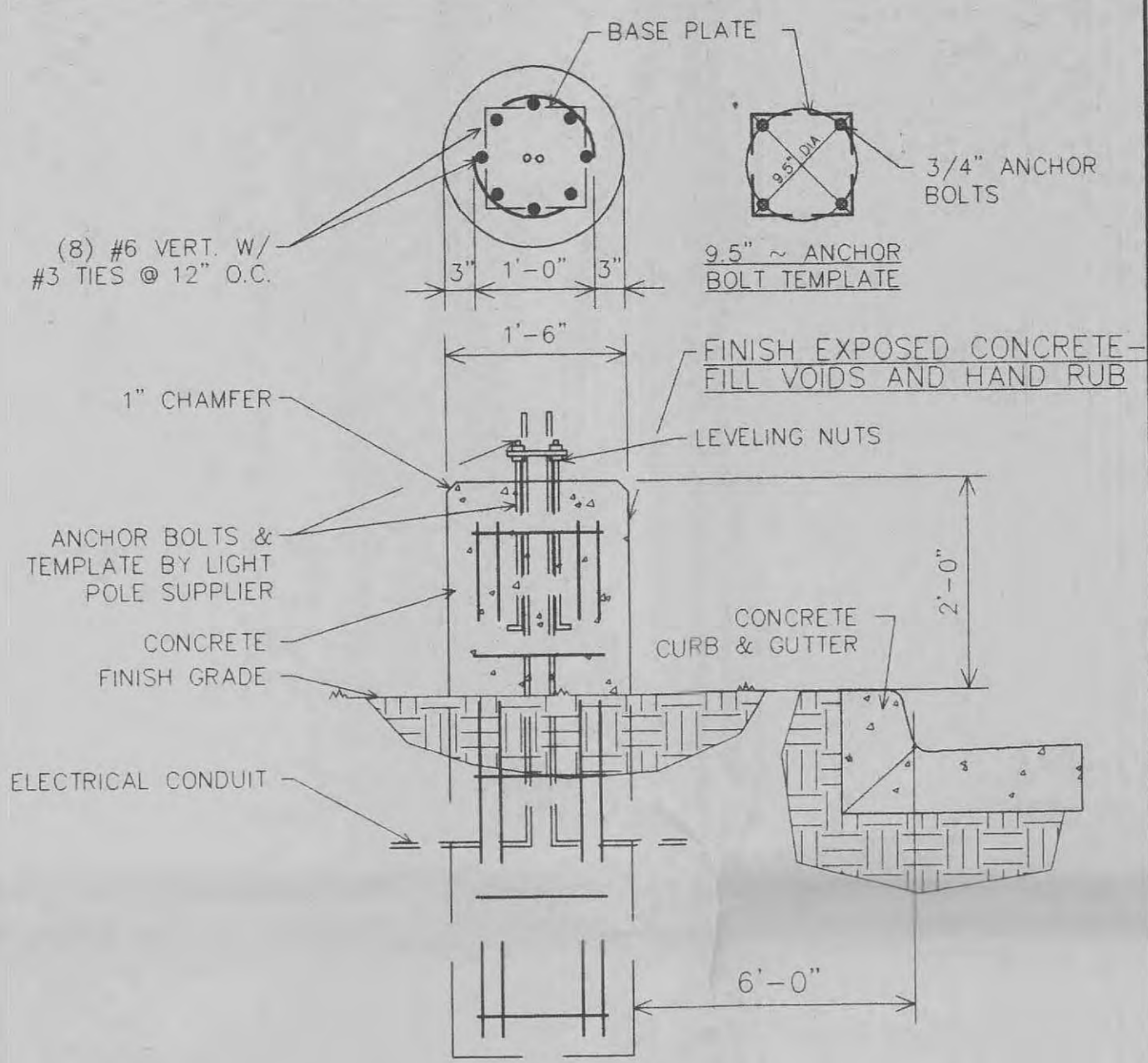

LIGHT POLE BASE DETAIL

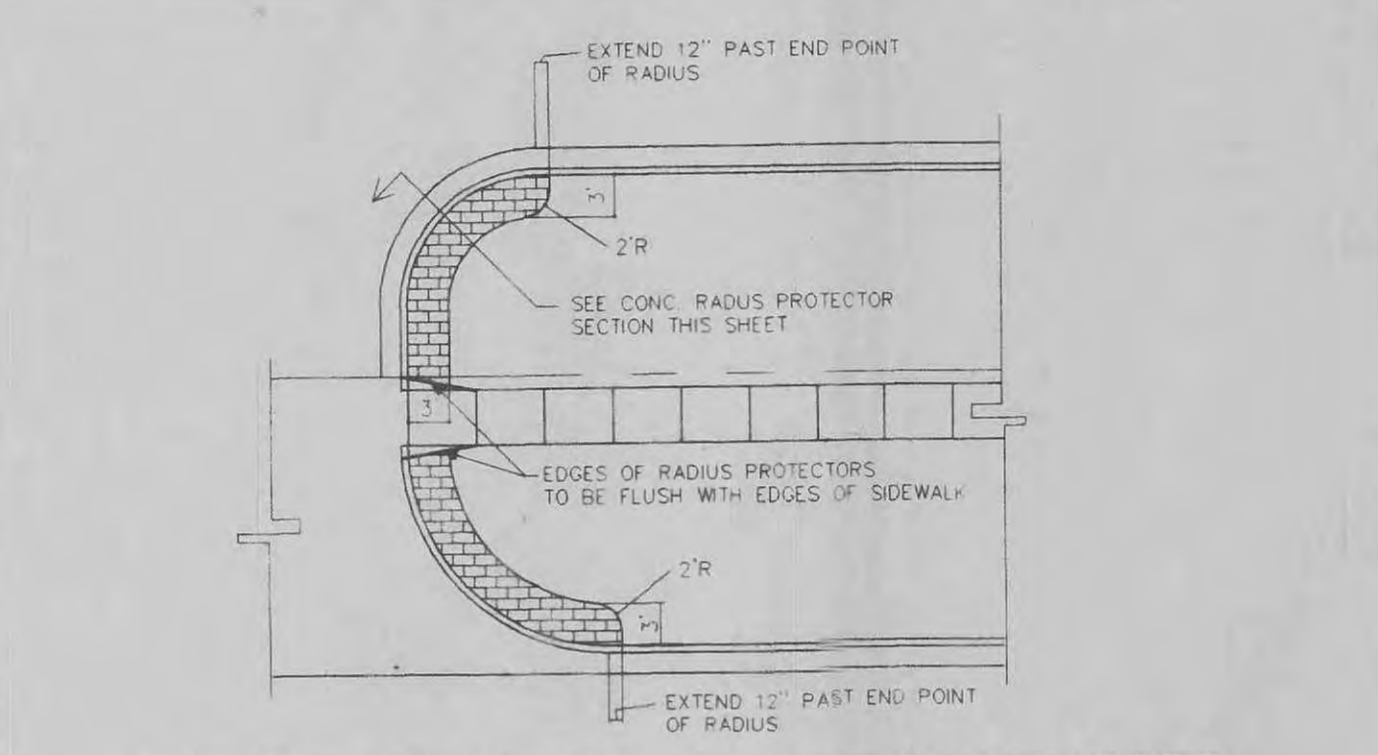

TYPICAL PLAN FOR RADIUS PROTECTORS

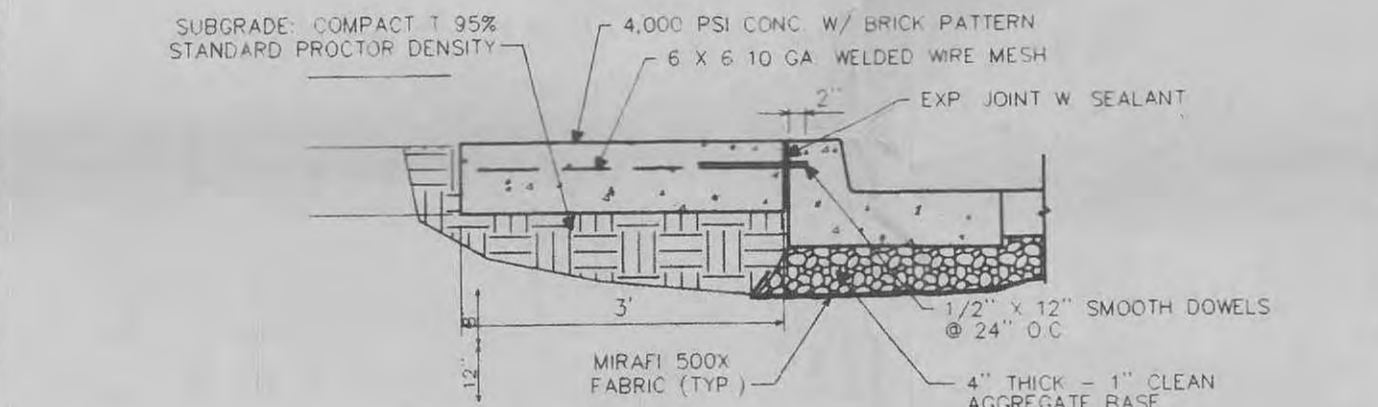

CONC. RADIUS PROTECTOR SECTION

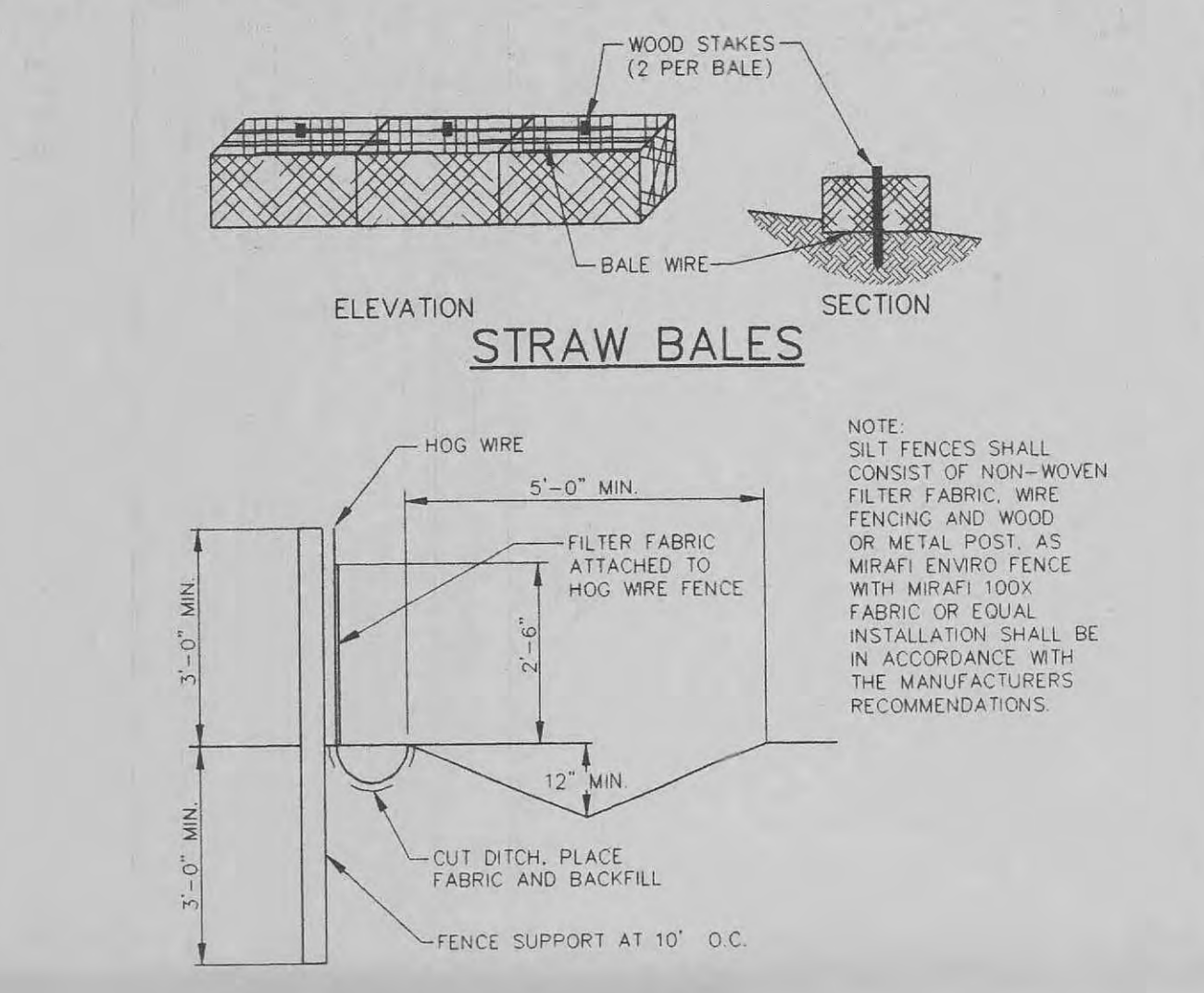

SILTATION CONTROL FENCE & SWALE

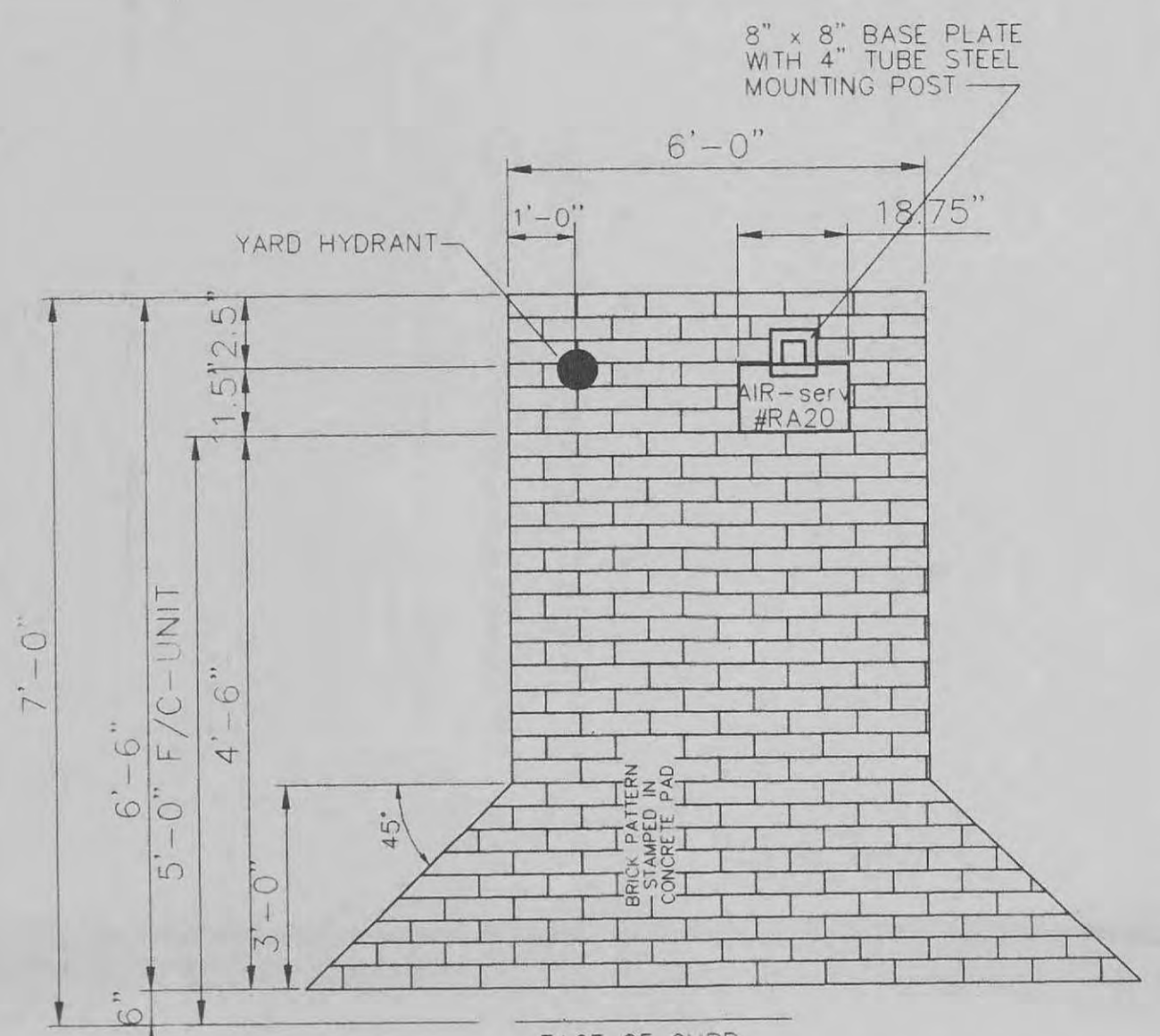

TYPICAL AIR COMPRESSOR / YARD HYDRANT ON A CONCRETE PAD - REVISED

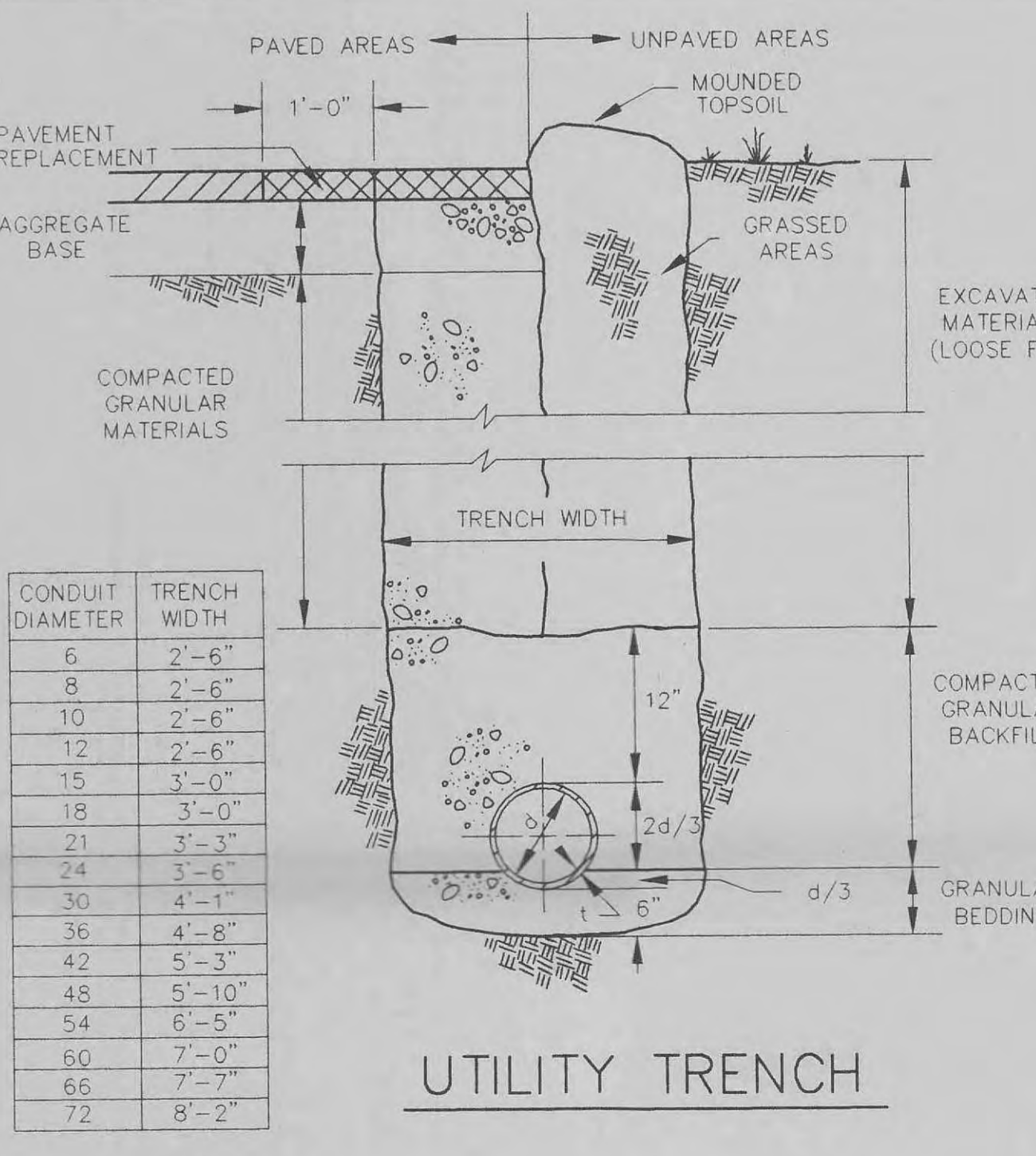

UTILITY TRENCH

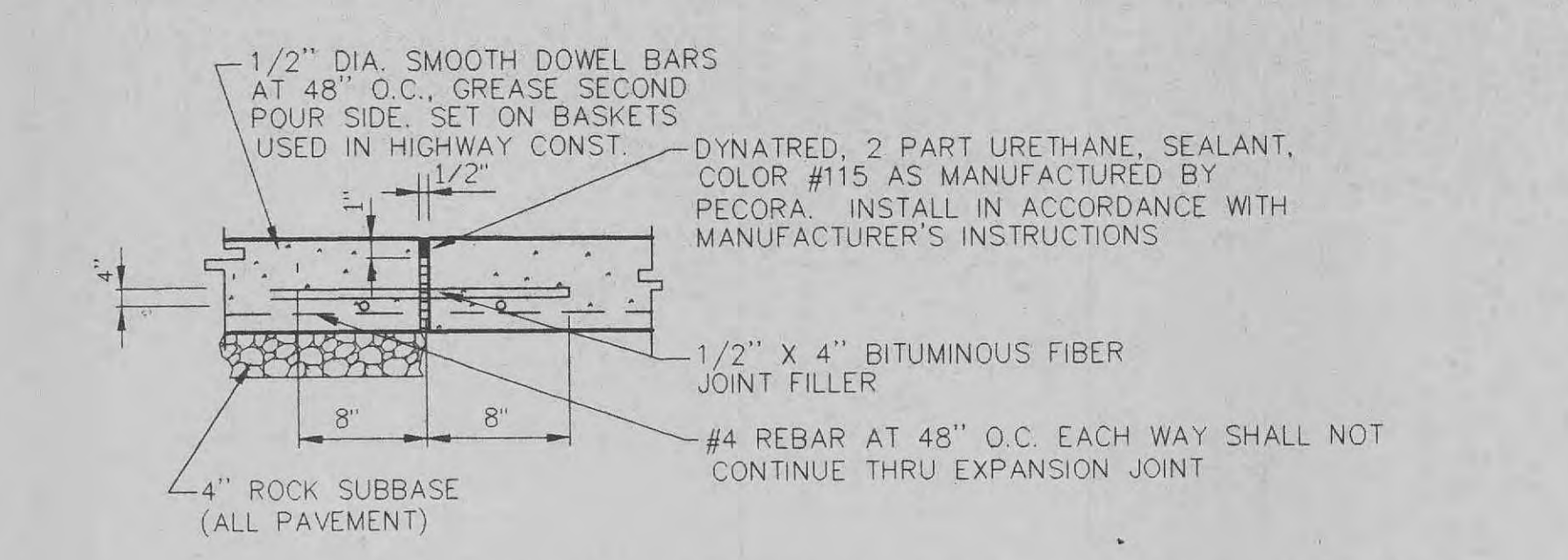

TYP. CONCRETE PAVING, EXPANSION JOINT DETAIL "A"

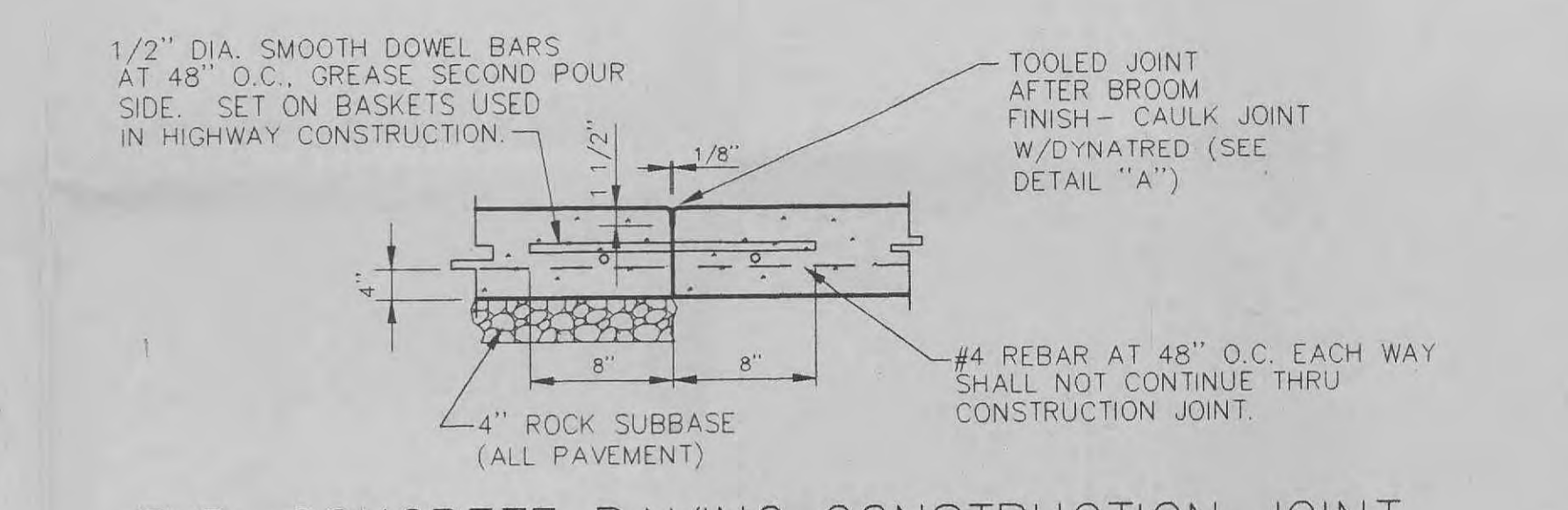

TYP. CONCRETE PAVING CONSTRUCTION JOINT DETAIL "B"

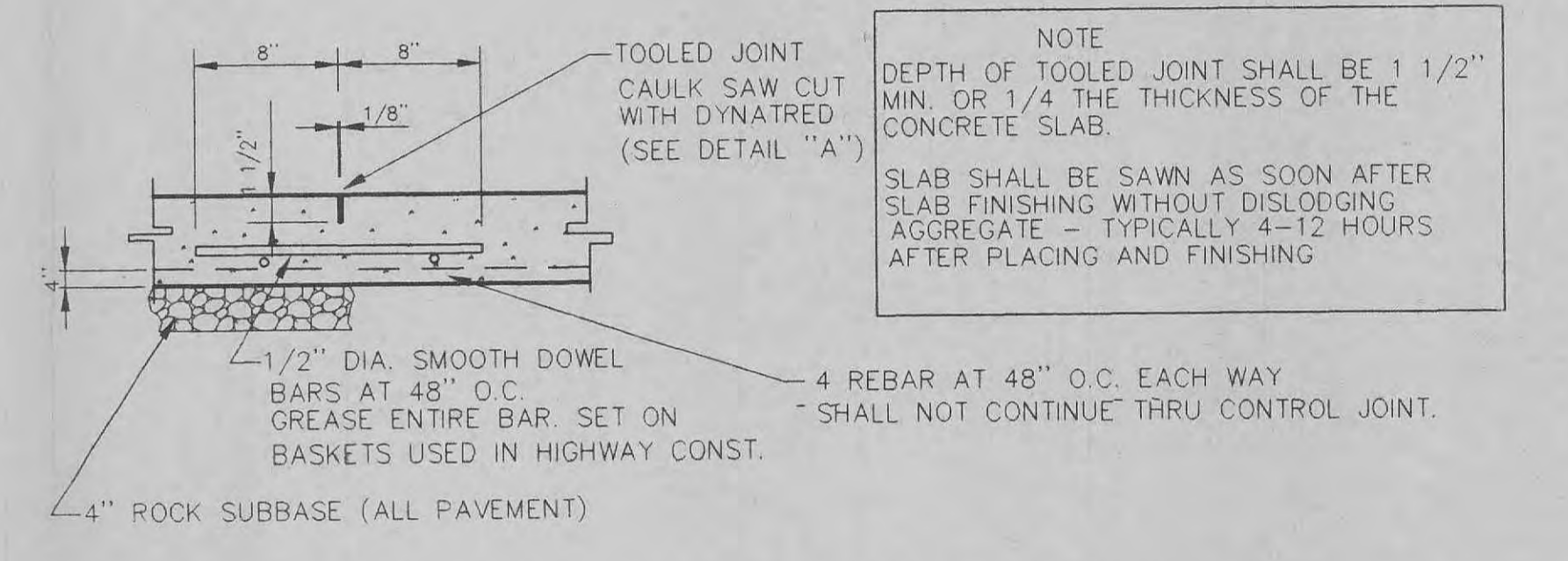

TYP. CONCRETE PAVING CONTROL JOINT DETAIL "C"

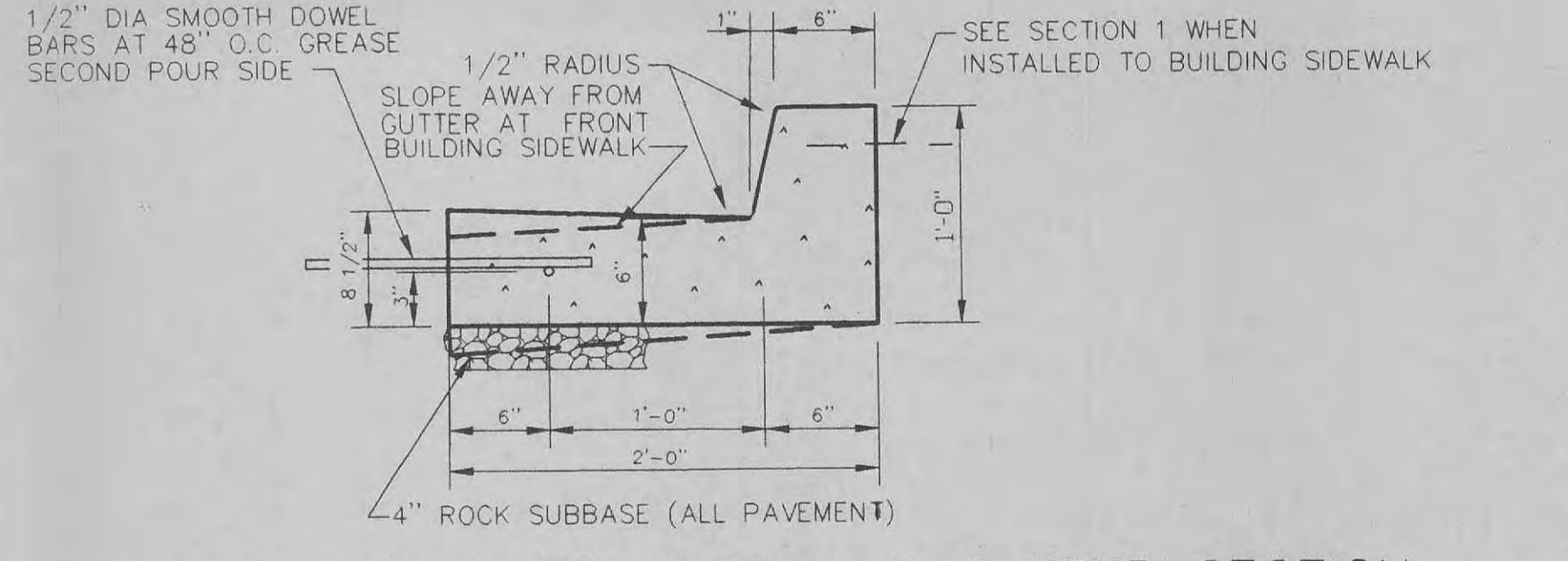

TYP. CONCRETE CURB AND GUTTER SECTION DETAIL "D"

REVISIONS

| NO. | DATE | DESCRIPTION |
|-----|------|-------------|
|     |      |             |
|     |      |             |
|     |      |             |
|     |      |             |

**QUIKTRIP #662**  
**CONST. NOTES & DETAILS**

935 BRYAN RD. @ 1-70 SOUTH OUTER RD. O'FALLON, MISSOURI 63366  
**the clayton engineering company, inc.**  
 ENGINEERS • SURVEYORS • PLANNERS  
 1920 WESTLINE INDUSTRIAL DRIVE  
 ST. LOUIS, MISSOURI 63148  
 (314) 892-8888 FAX: (314) 892-8888  
 EMAIL: CLAYTON@PRIMARY.NET

|                |         |
|----------------|---------|
| Designed       | JMP     |
| Drawn          | DJB     |
| Checked        | DJB     |
| Date           | 6/21/99 |
| Project Number | 97216   |
| Sheet Number   | 3 of 4  |