

MISSOURI INTERSTATE HIGHWAY 70

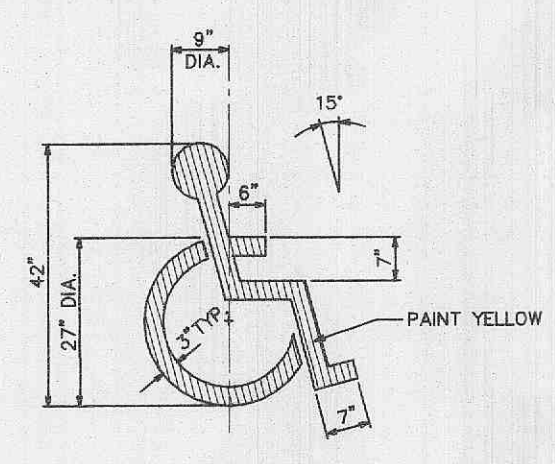

PAINTED HANDICAPPED PARKING SYMBOL NOT TO SCALE

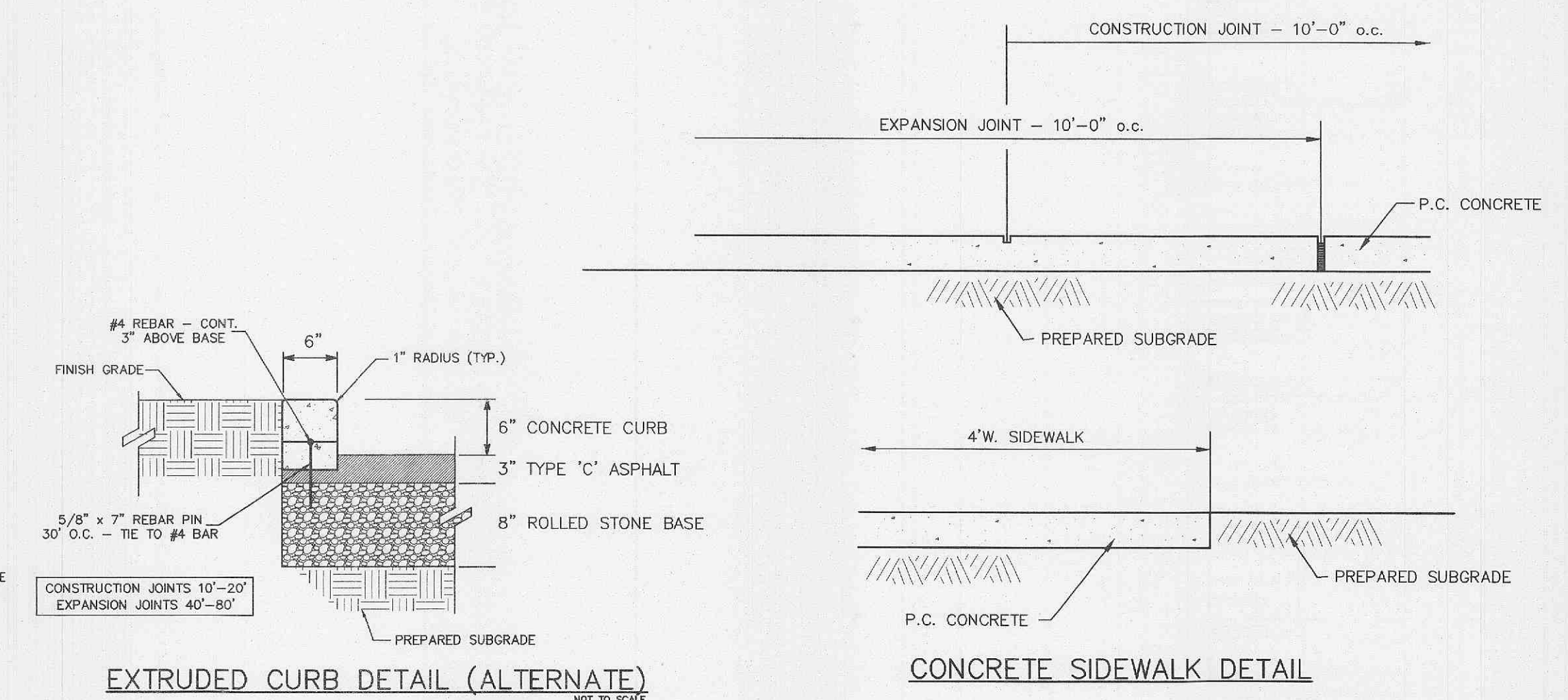
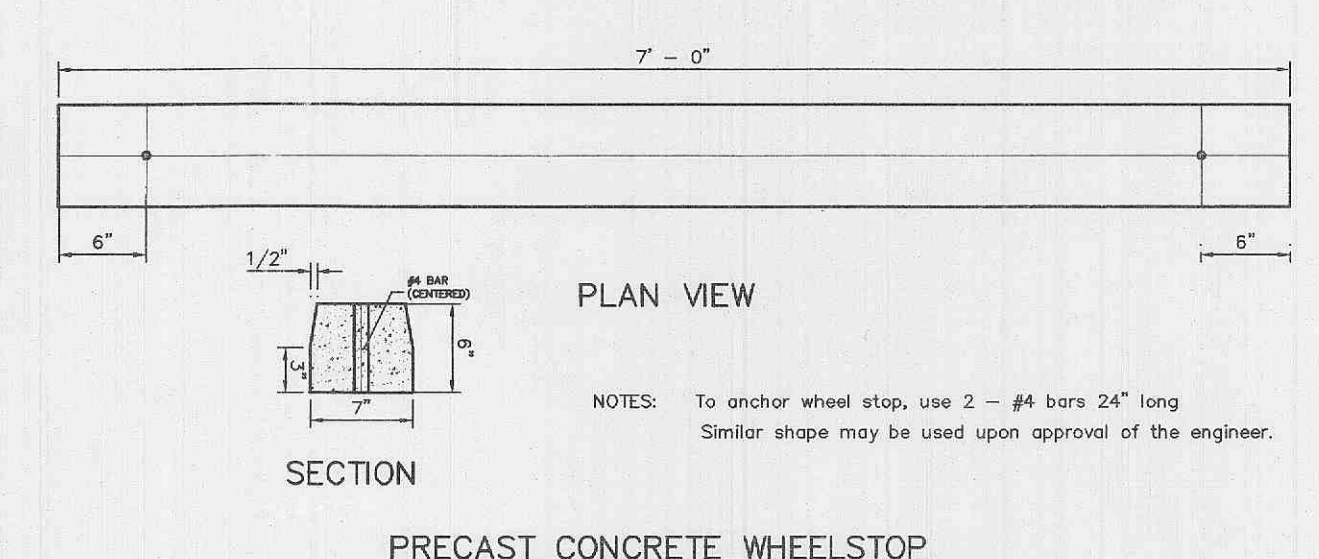
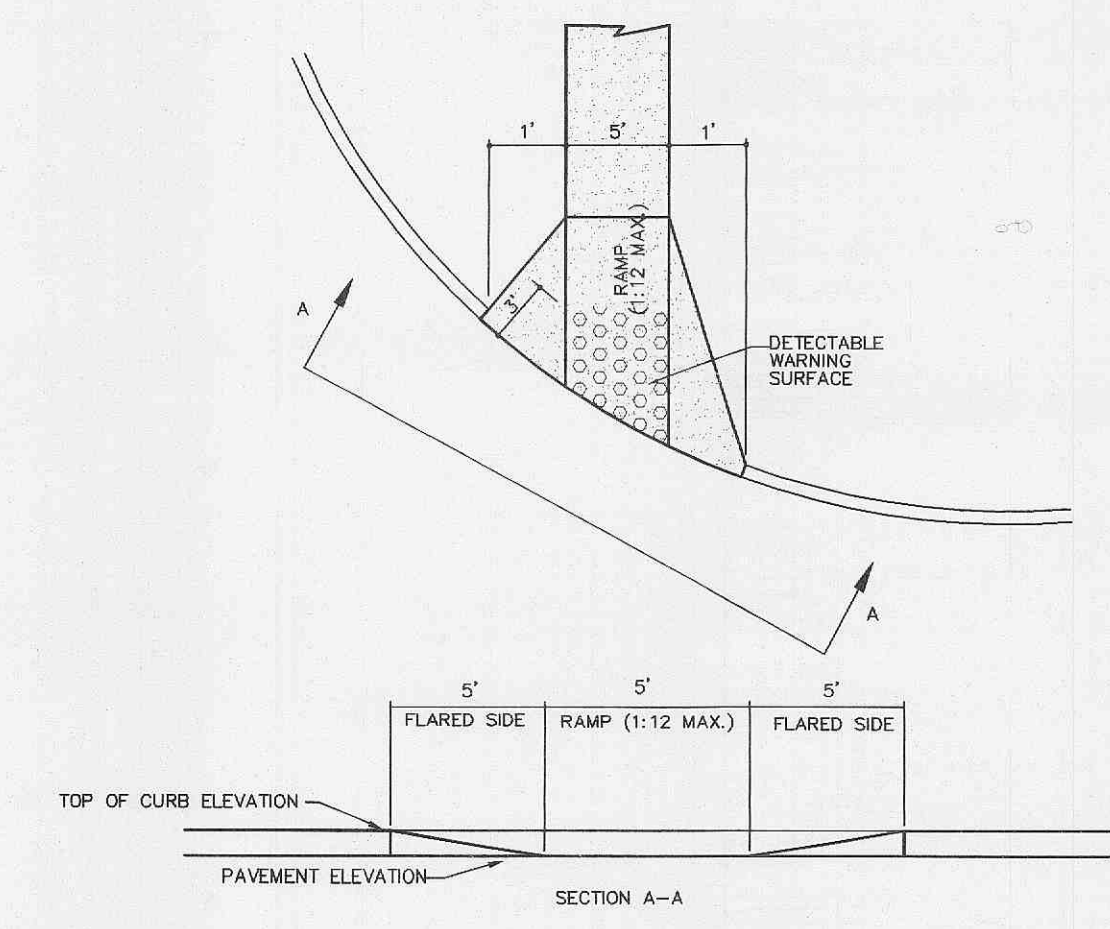
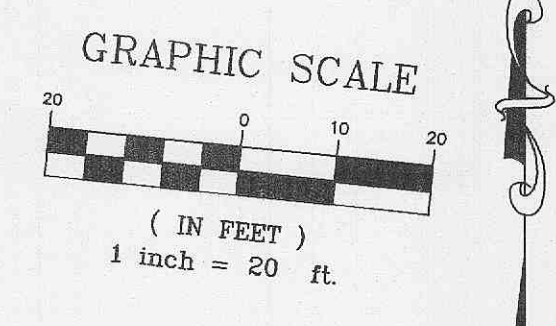
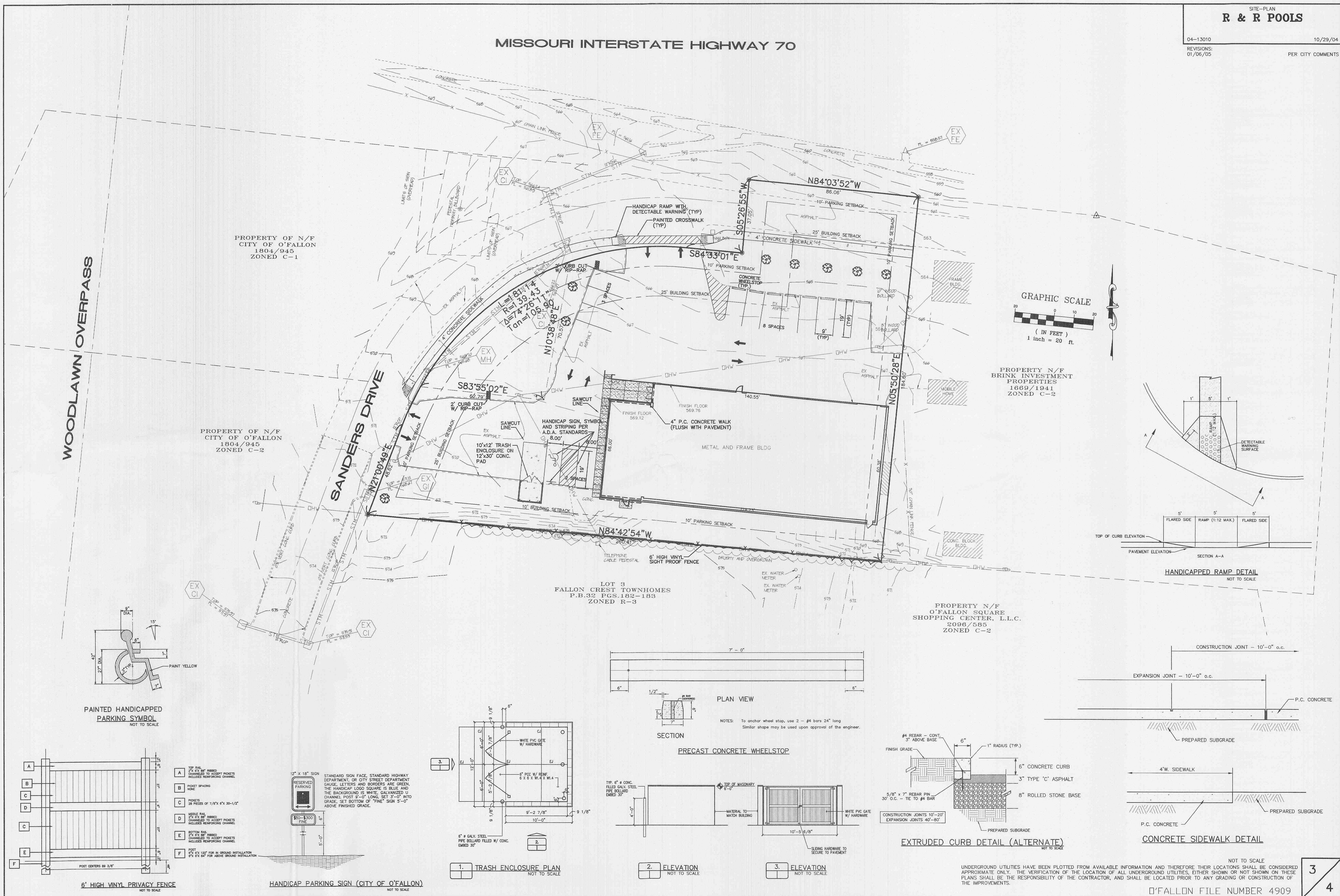
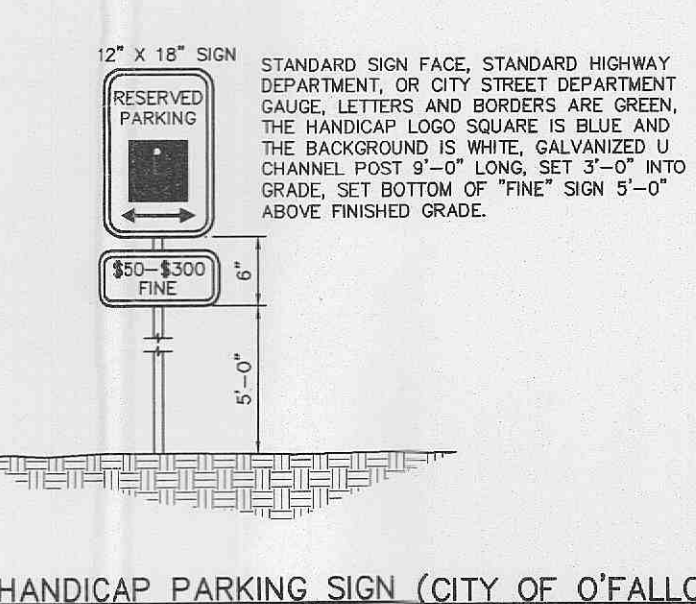

HANDICAP PARKING SIGN (CITY OF O'FALLON) NOT TO SCALE

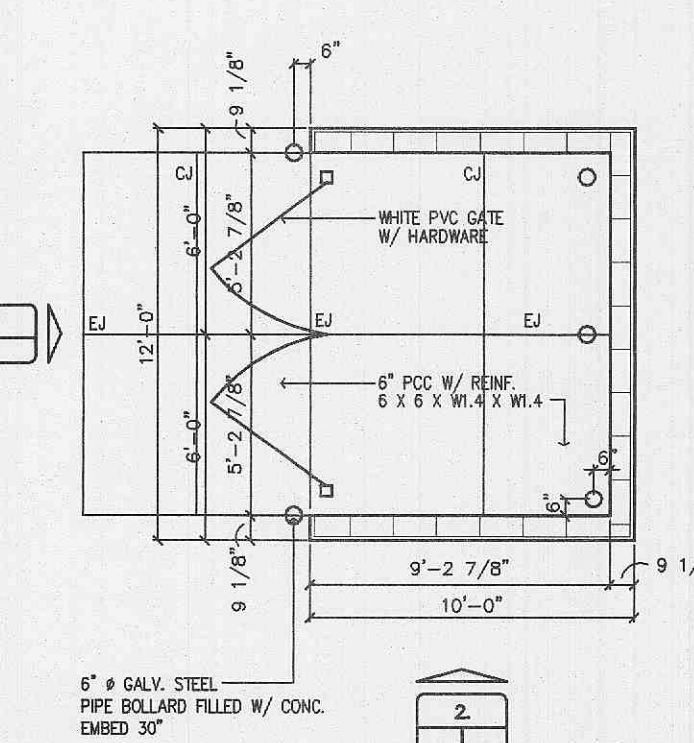

1. TRASH ENCLOSURE PLAN NOT TO SCALE

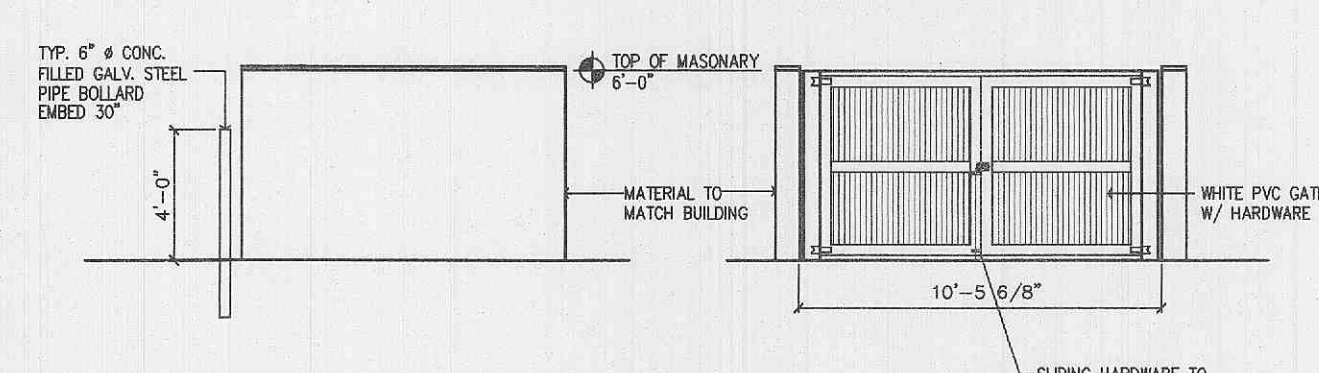

2. ELEVATION NOT TO SCALE

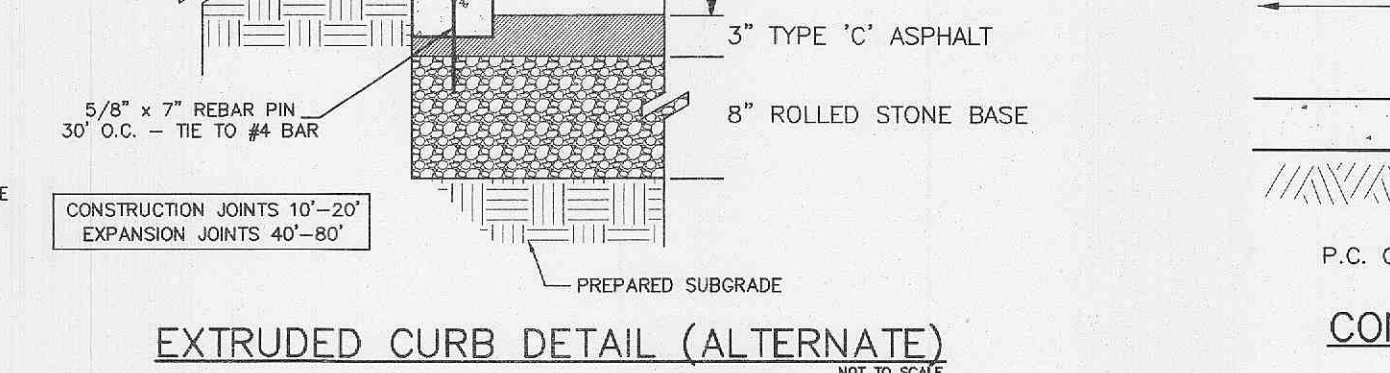

3. ELEVATION NOT TO SCALE

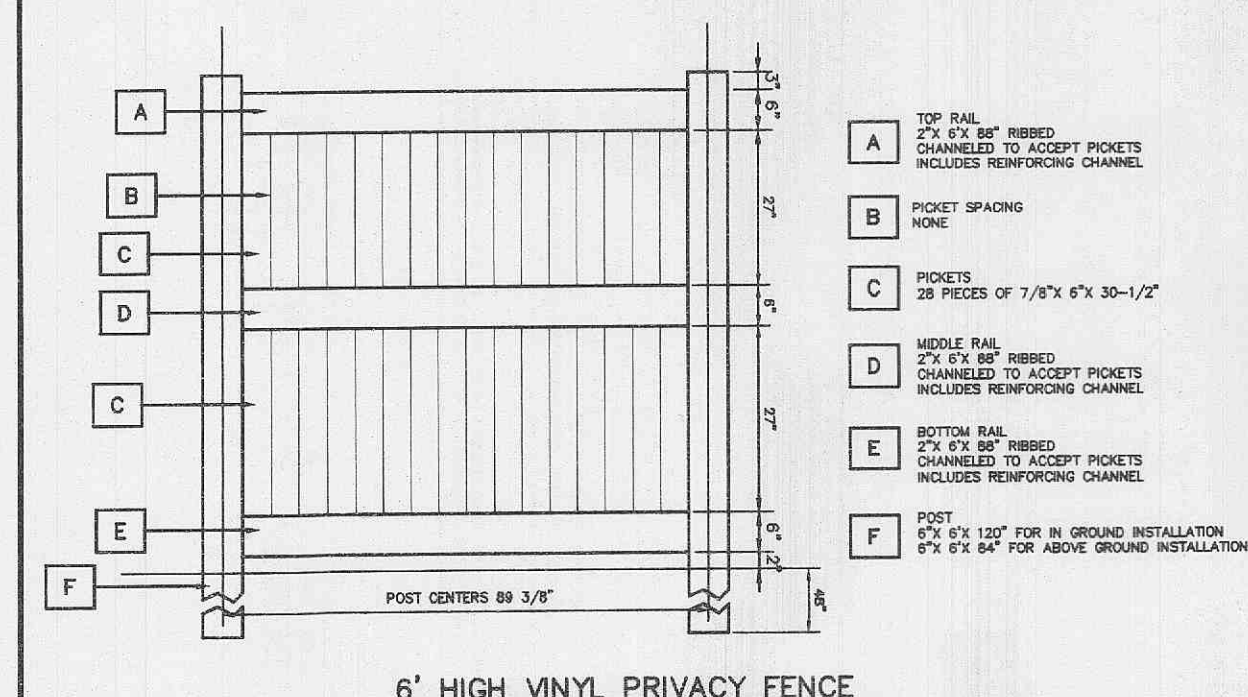

6' HIGH VINYL PRIVACY FENCE NOT TO SCALE

NOT TO SCALE  
UNDERGROUND UTILITIES HAVE BEEN PLOTTED FROM AVAILABLE INFORMATION AND THEREFORE THEIR LOCATIONS SHALL BE CONSIDERED APPROXIMATE ONLY. THE VERIFICATION OF THE LOCATION OF ALL UNDERGROUND UTILITIES, EITHER SHOWN OR NOT SHOWN ON THESE PLANS SHALL BE THE RESPONSIBILITY OF THE CONTRACTOR, AND SHALL BE LOCATED PRIOR TO ANY GRADING OR CONSTRUCTION OF THE IMPROVEMENTS.

E:\DWG\13000PLUS\13010 R&R POOLS\construction\13010con.dwg, SITE(S), 2/16/2005 1:49:38 PM, Station 63 KTK